

S.NO	CATALOG NUMBER	L	A	B	C
1	6ABV-350M	3.00 [76]	1.03 [26]	6	4
2	6ABV350MI	3.00 [76]	1.03 [26]	6	4
3	8ABV-350M	4.75 [121]	1.25 [32]	8	6
4	8ABV350MI	4.75 [121]	1.25 [32]	8	6
5	10ABV-350M	4.75 [121]	0.94 [24]	10	6
6	10ABV350MI	4.75 [121]	0.94 [24]	10	6
7	12ABV-350M	6.50 [165]	1.10 [28]	12	8
8	12ABV350MI	6.50 [165]	1.10 [28]	12	8

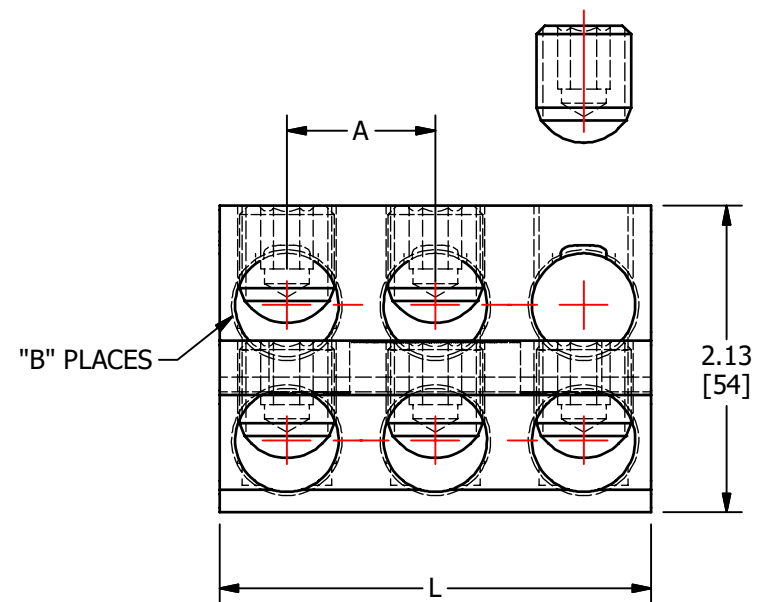

SCREWS ARE SUPPLIED WITH CONNECTOR AND COMES FULLY ASSEMBLED.

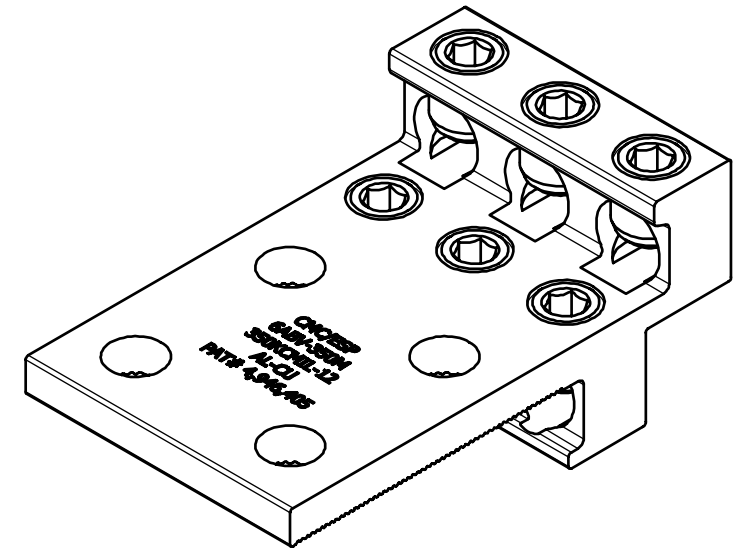
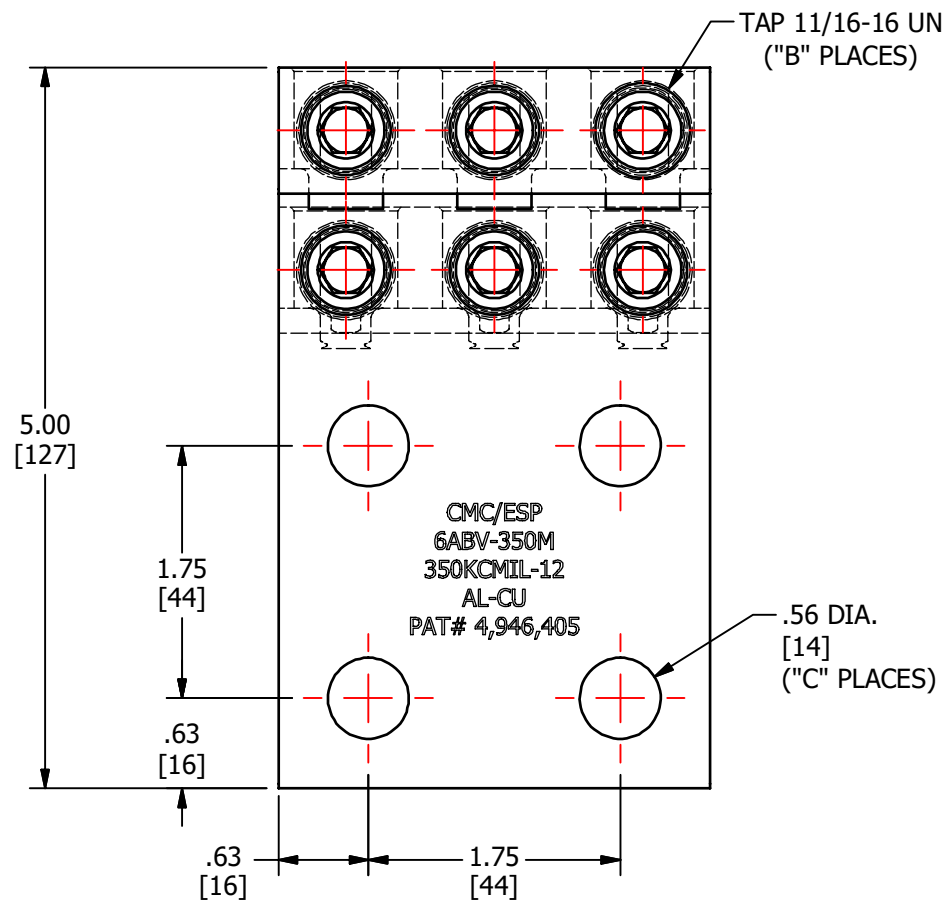
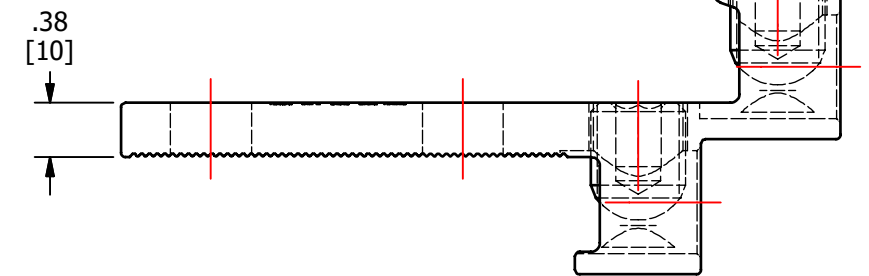

				DRAWN BY: TS 01/24/19		NAME OF PART: LUG ASSEMBLY		CAT. NO.: SEE TABLE	
				CHECKED BY:		DWG NO: C58701106-S (CHARTED)		B	
A NEW DRAWING CREATED				01/24/19		TS		DRAWING NOT TO SCALE	
REV.	DESCRIPTION	ECN	DATE	INIT.	SHEET NO: 1 OF 1				

THIS INFORMATION IS PROPRIETARY TO CONNECTOR MFG. CO. AND IS NOT TO BE DISCLOSED OUTSIDE OF CONNECTOR MFG. CO. WITHOUT A CONFIDENTIALITY AGREEMENT



CONNECTOR MANUFACTURING CO.

HAMILTON, OHIO