

S.NO	CATALOG NUMBER	L	"T" TAP SIZE	CONDUCTOR SIZE
1	WSD-250I	4.19 [106]	5/8-18 UNF	250 KCMIL-12
2	WSD-350I	4.19 [106]	11/16-16 UNF	350 KCMIL-12
3	WSD500I	5.00 [127]	13/16-16 UN	500 KCMIL-12
4	WSD500	5.00 [127]	13/16-16 UN	500 KCMIL-12
5	WSD750I	5.75 [146]	15/16-16 UN	750 KCMIL-12
6	WSD750	5.75 [146]	15/16-16 UN	750 KCMIL-12

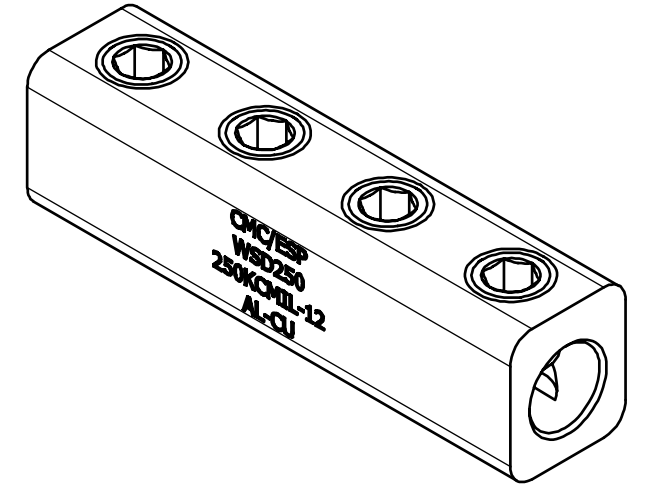

SCREWS ARE SUPPLIED WITH CONNECTOR AND COMES FULLY ASSEMBLED.

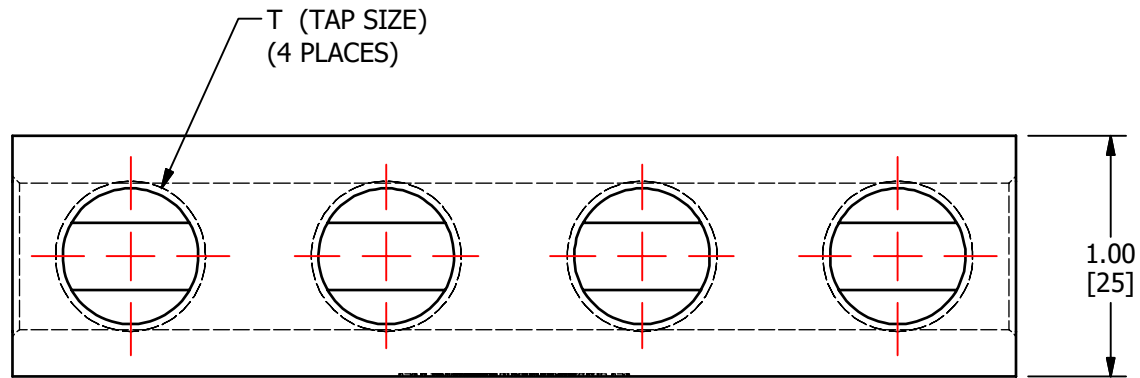
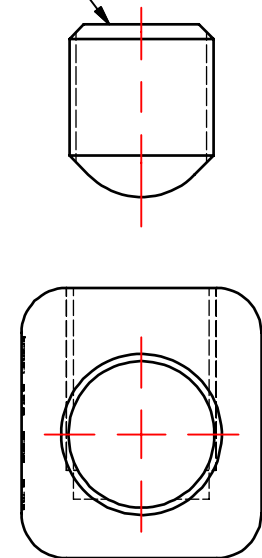
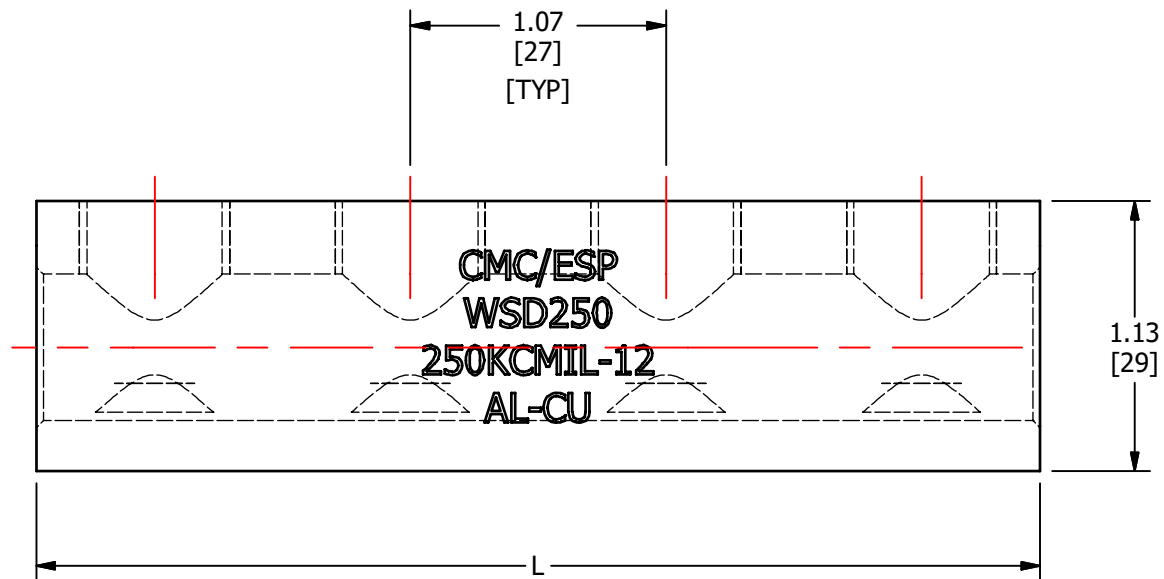

						TO ORDER CMC PRODUCTS CALL 1-513-860-4455	DRAWN BY: TS 12/14/18	NAME OF PART: SPLICER-REDUCER	CAT. NO.: SEE TABLE
						FOR PRODUCT INFO: http://www.cmcclugs.com	CHECKED BY:	DWG NO: C58701637I-S (CHARTED)	B
A	NEW DRAWING CREATED		12/14/18	TS			DRAWING NOT TO SCALE		SHEET NO: 1 OF 1
REV.	DESCRIPTION	ECN	DATE	INIT.					

THIS INFORMATION IS PROPRIETARY TO CONNECTOR MFG. CO. AND IS NOT TO BE DISCLOSED OUTSIDE OF CONNECTOR MFG. CO. WITHOUT A CONFIDENTIALITY AGREEMENT



CONNECTOR MANUFACTURING CO.

HAMILTON, OHIO

