

CATALOG NO.	CABLE DIAMETER RANGE	DIM "A"	DIM "B"	DIM "C"	DIM "D"	ULTIMATE BODY STRENGTH	WEIGHT	STANDARD PACK
WEGADSS100	.236 TO .315 [6.00 TO 8.00]	15.5 [393.7]	4.25 [108]	2.25 [57.2]	1.25 [31.8]	750 [340.19]	.884 [.40]	50
WEGADSS101	.315 TO .394 [8.00 TO 10.00]	15.5 [393.7]	4.25 [108]	2.25 [57.2]	1.25 [31.8]	750 [340.19]	.884 [.40]	50
WEGADSS102	.394 TO .472 [10.00 - 12.00]	21.25 [539.8]	7.87 [200]	3.3 [83.8]	1.65 [42]	1650 [748.43]	.884 [.40]	30
WEGADSS103	.472 TO .551 [12.00 TO 14.00]	21.25 [539.8]	7.87 [200]	3.3 [83.8]	1.65 [42]	1650 [748.43]	.884 [.40]	30
WEGADSS104	.551 TO .630 [14.00 TO 16.00]	21.25 [539.8]	7.87 [200]	3.3 [83.8]	1.65 [42]	1650 [748.43]	.884 [.40]	30
WEGADSS105	.630 TO .709 [16.00 TO 18.00]	21.25 [539.8]	7.87 [200]	3.3 [83.8]	1.65 [42]	1650 [748.43]	.884 [.40]	30
WEGADSS106	.709 T .748 [18.00 TO 19.00]	21.25 [539.8]	7.87 [200]	3.3 [83.8]	1.65 [42]	1650 [748.43]	.884 [.40]	30

ITEM	DESCRIPTION	MATERIAL
1	BODY	THERMOPLASTIC
2	BAIL	STAINLESS STEEL
3	BAIL CAP	THERMOPLASTIC

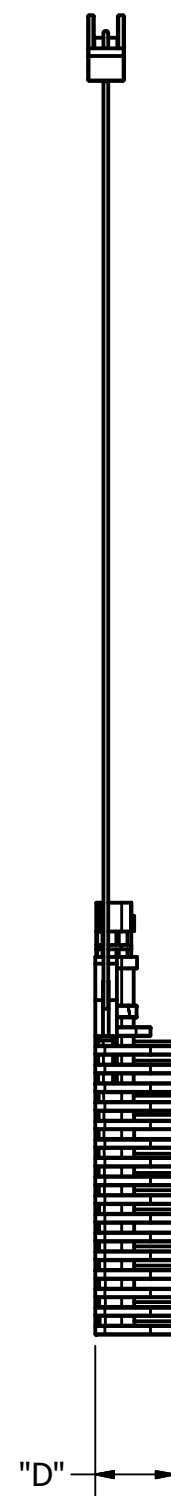
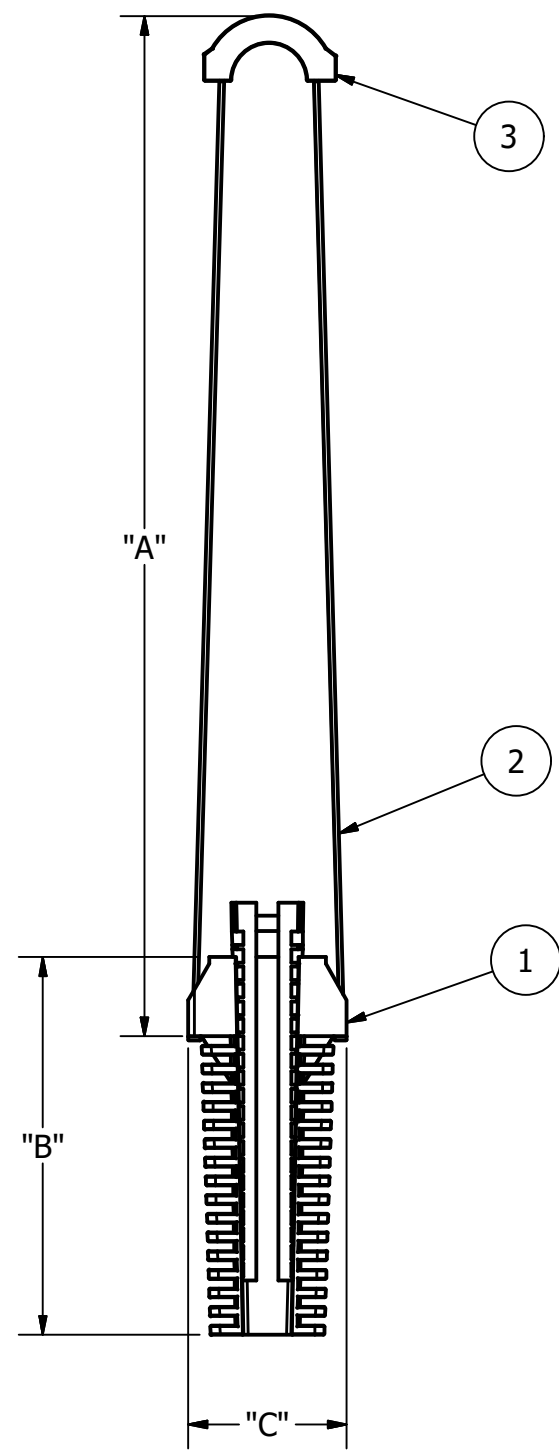

NOTES:

- ALL DIMENSIONS FOR REFERENCE ONLY. DISTANCE IN. [MM], FORCE LBS. [kN], TORQUE IN. LBS. [N.m], & WEIGHT LBS. [KG].
- RATINGS:
 - NA
- CERTIFICATIONS, SPECIFICATIONS, & STANDARDS:
 - SPANS UP TO 325 FT
 - UV RESISTANT
- SUFFIXS & VARIANT CONFIGURATION:
 - NA

79123	07/08/19	HD	RG	HPS.	HUBBELL® POWER SYSTEMS <small>POWER SYSTEMS, INC.</small>			
EC #	DATE	CHG BY	RESP ENG					
DESC OF DWG: REDRAWN IN INVENTOR NEW CC-TEMPLATE				CONFIDENTIAL: THIS DRAWING AND ITS CONTACTS ARE CONFIDENTIAL AND THE EXCLUSIVE PROPERTY OF HUBBELL POWER SYSTEMS. NO PUBLICATION, DISTRIBUTION OR COPIES MAY BE MADE WITHOUT THE WRITTEN CONSENT OF HUBBELL POWER SYSTEMS. HUBBELL POWER SYSTEMS UNPUBLISHED ALL RIGHTS RESERVED UNDER THE COPYRIGHT LAWS	TITLE WEGADSS, ADSS WEDGE DEADEND			
REASON (S) FOR CHANGE: DISPOSITION OF MAT'L:					<table border="1"> <tr> <td>SIZE C</td> <td>DWG NO. CC-23213</td> <td>CAT / PART / ASSY NO. SEE CHART</td> <td>REV 01</td> </tr> </table>	SIZE C	DWG NO. CC-23213	CAT / PART / ASSY NO. SEE CHART
SIZE C	DWG NO. CC-23213	CAT / PART / ASSY NO. SEE CHART	REV 01					
				DO NOT SCALE THIS DRAWING	<table border="1"> <tr> <td>DRN BY JES</td> <td>DATE 09/18/15</td> <td>SHEET 1 OF 1</td> </tr> </table>	DRN BY JES	DATE 09/18/15	SHEET 1 OF 1
DRN BY JES	DATE 09/18/15	SHEET 1 OF 1						