

CATALOG NO.	CABLE DIA. RANGE MIN. - MAX.	CONDUCTOR SPACING	DIM A	DIM B	DIM C	COLOR CODE	WEIGHT	STANDARD PACK
GS931	.162 - .398 [3.21] - [10.13]	8.000 [203.2]	8.500 [216.33]	16.750 [426.29]	8.000 [203.2]	WHITE	.230 [.10]	100
GS932	.257 - .523 [6.54] - [13.31]	8.000 [203.2]	8.500 [216.33]	16.875 [429.60]	8.000 [203.2]	BLACK	.230 [.10]	100
GS951	.162 - .398 [3.21] - [10.13]	12.000 [304.8]	8.500 [216.33]	24.750 [629.89]	12.000 [304.8]	WHITE	.300 [.14]	100
GS952	.257 - .523 [6.54] - [13.31]	12.000 [304.8]	8.500 [216.33]	24.875 [533.20]	12.000 [304.8]	BLACK	.300 [.14]	100

ITEM	DESCRIPTION	MATERIAL
1	TIE	PVC

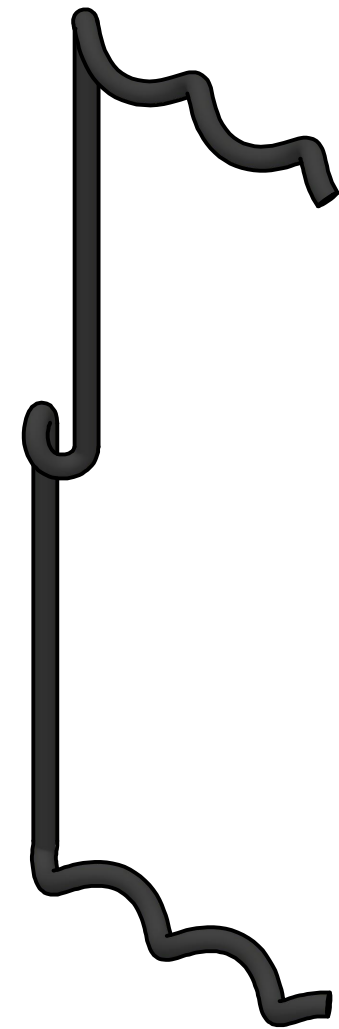
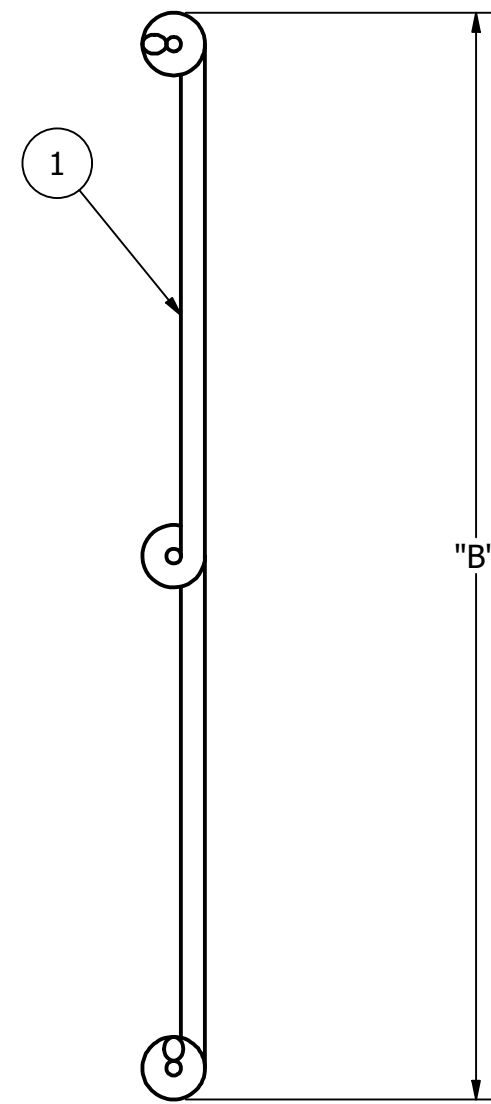
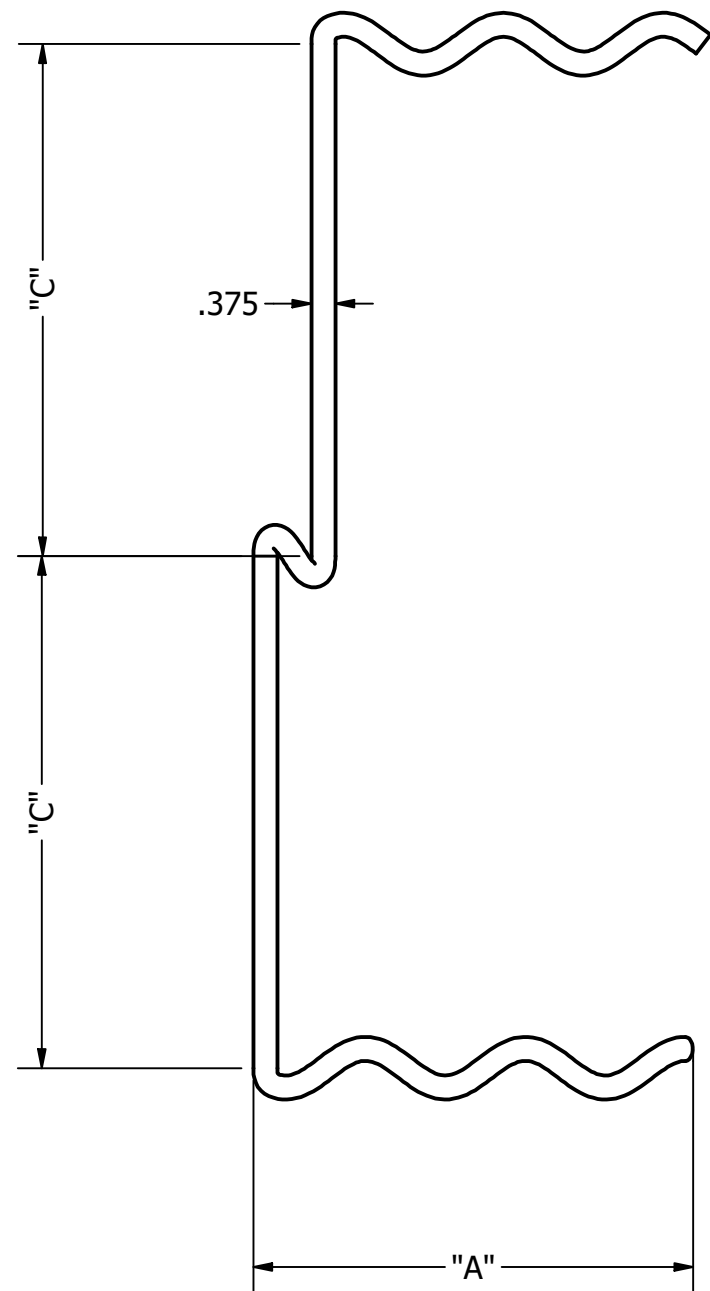

NOTES:

- ALL DIMENSIONS FOR REFERENCE ONLY. DISTANCE IN. [MM], FORCE LBS. [kN], TORQUE IN. LBS. [N.m], & WEIGHT LBS. [KG].
- RATINGS:
 - V-0 FLAMMABILITY RATING PER UL 94
- CERTIFICATIONS, SPECIFICATIONS, & STANDARDS:
 - UV STABILIZED - MIN. 2.5% CARBON BLACK FILLED BY WEIGHT
- SUFFIXES & VARIANT CONFIGURATION:
 - "M" - FOR YELLOW SPIRAL CUT TUBE AS A CUSTOMER MARKER

80141	10/04/19	AD	RG	HPS.	HUBBELL® POWER SYSTEMS
EC #	DATE	CHG BY	RESP ENG		
DESC OF DWG: INITIAL RELEASE				CONFIDENTIAL: THIS DRAWING AND ITS CONTACTS ARE CONFIDENTIAL AND THE EXCLUSIVE PROPERTY OF HUBBELL POWER SYSTEMS. NO PUBLICATION, DISTRIBUTION OR COPIES MAY BE MADE WITHOUT THE WRITTEN CONSENT OF HUBBELL POWER SYSTEMS. HUBBELL POWER SYSTEMS UNPUBLISHED ALL RIGHTS RESERVED UNDER THE COPYRIGHT LAWS	TITLE GS900, FORMED WIRE COMPOSITE SPACER TIES
REASON (S) FOR CHANGE: DISPOSITION OF MAT'L:					SIZE: C DWG NO.: CC-26173 DO NOT SCALE THIS DRAWING
					REV: 00 SHEET: 1 OF 1