

CABLE		MOLD #	PRICE KEY	WELD METAL	HANDLE CLAMPS
RUN	TAP				
#8	#8	M-5709	18†	15	40-4565-00
#6	#6	M-5618	18†	25	40-4565-00
#6	#6	M-1934	18†	25	40-4565-00

CC-14 TYPE MOLDS HORIZONTAL PARALLEL THROUGH CABLES

CC-14 TYPE MOLDS ARE USED TO JOIN HORIZONTAL PARALLEL THROUGH RUN CABLES. CABLES RUN SIDE BY SIDE IN THE MOLD. SIZE RANGE IS #8 THROUGH #6 SOLID OR CONCENTRIC STRANDED COPPER CONDUCTORS.

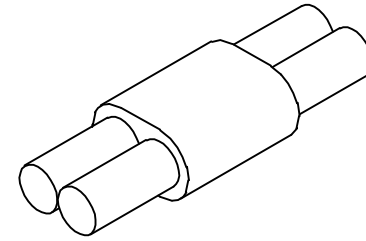

NOTES:

- FOR SIZES NOT LISTED, CONTACT THERMOWELD®.
- MOLDS LISTED ARE FOR CONCENTRIC STRANDED CABLE. ADD SUFFIX "-S" TOMOLD NUMBER FOR SOLID CONDUCTORS.
- FOR HEAVY DUTY MOLDS, MOLDS WITH WEAR PLATES OR MOLDS FOR COPPERWELD® CABLE, CONTACT THERMOWELD®.
- FOR EXPEDITED SERVICE, CONTACT THERMOWELD®.
- REQUIRED TOOLS;
HANDLE CLAMPS W/ FLINT IGNITOR (40-4565-00)
38-0309-00 ~ FLINT IGNITOR
- OTHER RECOMMENDED ACCESSORIES;
40-0319-01 ~ MOLD CLEANER FOR CARTRIDGE SIZES #15-#65
40-0319-03 ~ MOLD CLEANER FOR CARTRIDGE SIZES #90-#500
38-3922-00 ~ MOLD CLEANING BRUSH
38-0135-00 ~ CABLE CLEANING BRUSH
38-0330-00 ~ CABLE CLAMP

† ~ SOLD COMPLETE WITH HANDLES

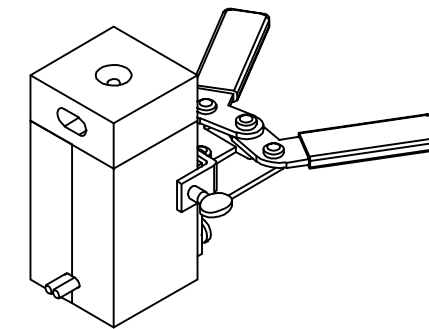
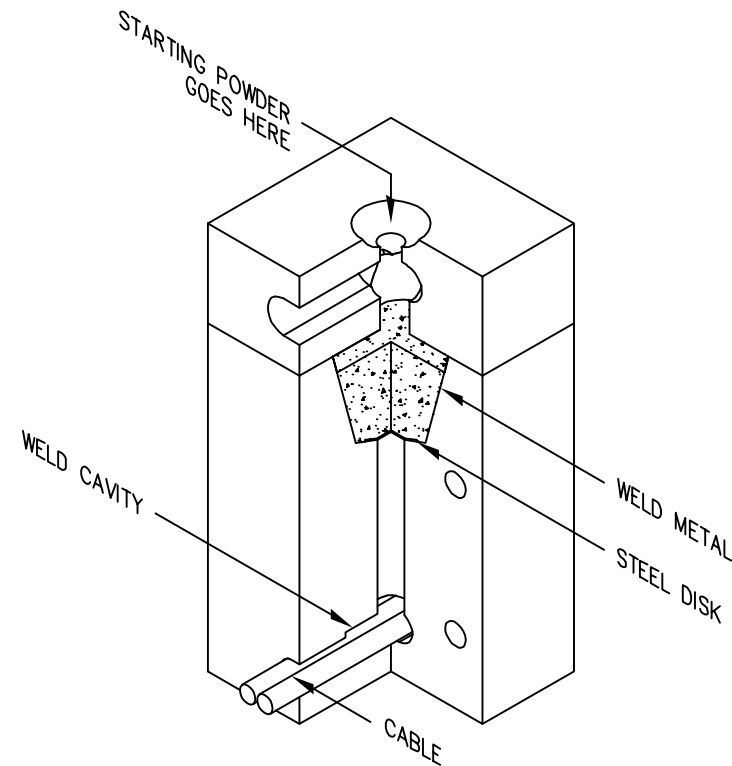

SHOWN WITH
HANDLE CLAMPS

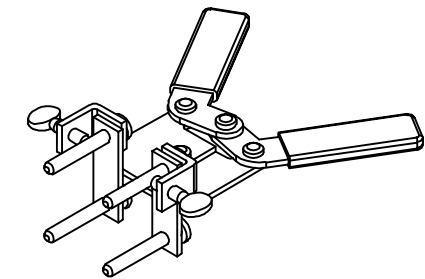

REF. 40-4565-00
HANDLE CLAMPS

thermOweld®

REV	EC #	DESCRIPTION	DATE	INITIALS
B	211203014949	TEMPLATE UPDATED	12/03/21	BE
A	2585	ADDED MOLD # M-1934	10/30/13	LR
REVISION HISTORY				

TO ORDER thermOweld® PRODUCTS CALL UNITED STATES 1-800-558-1373 CANADA: 1-800-387-6487 FOR PRODUCT INFO: http://www.burndy.com	SIGNATURES				
	DRAWN BY	DATE	APPROVED BY	DATE	
	B. MCKASKLE	4/4/05	<i>MAC</i>	10/30/13	
MATERIAL				CC-14 TYPE MOLDS HORIZONTAL PARALLEL THROUGH CABLES	
SIZE	DWG NO.			REV	
C	CD-0606			B	
SCALE	NTS	SHEET		1 OF 1	