

GRD ROD	CABLE	MOLD #	PRICE KEY	WELD METAL	HANDLE CLAMPS
1/2"	#6	M-5786	4	65	B-106
	#4	M-5388	4	90	B-106
	#2	M-537	4	90	B-106
	#1	M-538	4	90	B-106
	1/0	M-539	4	90	B-106
	2/0	M-540	4	90	B-106
	3/0	M-541	4	115	B-106
	4/0	M-542	4	115	B-106
	250 MCM	M-543	4	150	B-106
	300 MCM	M-544	4	200	B-106
5/8"	#6	M-5815	4	65	B-106
	#4	M-5915	4	90	B-106
	#2	M-545	4	90	B-106
	#1	M-546	4	90	B-106
	1/0	M-547	4	90	B-106
	2/0	M-548	4	115	B-106
	3/0	M-549	4	115	B-106
	4/0	M-550	4	115	B-106
	250 MCM	M-551	4	150	B-106
	300 MCM	M-552	4	200	B-106
3/4"	350 MCM	M-553	4	200	B-106
	500 MCM	M-555	4	250	B-106
	#6	M-5787	4	65	B-106
	#4	M-6201	4	90	B-106
	#2	M-556	4	90	B-106
	#1	M-557	4	90	B-106
	1/0	M-558	4	115	B-106
	2/0	M-559	4	115	B-106
	3/0	M-560	4	115	B-106
	4/0	M-561	4	115	B-106
1"	250 MCM	M-562	4	150	B-106
	300 MCM	M-563	4	200	B-106
	350 MCM	M-564	4	200	B-106
	500 MCM	M-566	4	250	B-106
	750 MCM	M-567	5	2-200	B-107
	1/0	M-569	4	150	B-106
	2/0	M-570	4	150	B-106
	3/0	M-571	4	150	B-106
	4/0	M-572	4	150	B-106
	250 MCM	M-573	4	200	B-106
300 MCM	M-574	4	200	B-106	
350 MCM	M-575	4	200	B-106	
500 MCM	M-577	4	250	B-106	
750 MCM	M-578	5	2-200	B-107	
1000 MCM	M-579	5	500	B-107	

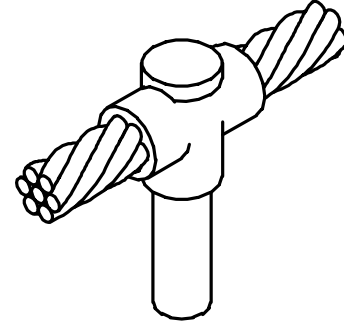

CR-2 TYPE MOLDS  
HORIZONTAL CABLE TO GROUND ROD

CR-2 TYPE MOLDS ARE USED TO JOIN HORIZONTAL THROUGH COPPER CABLE TO THE TOP OF A VERTICAL GROUND ROD.  
SIZE RANGE IS #6 THROUGH 1000 MCM SOLID OR CONCENTRIC STRANDED COPPER CONDUCTORS; 1/2" THROUGH 1" FOR THE GROUND ROD.

- NOTES:
- FOR SIZES NOT LISTED, CONTACT THERMOWELD®.
  - MOLDS LISTED ARE FOR CONCENTRIC STRANDED CABLE. ADD SUFFIX "-S" TO MOLD NUMBER FOR SOLID CONDUCTORS.
  - MOLDS LISTED ARE FOR COPPER CLAD GROUND RODS. FOR WELDING TO STEEL, STAINLESS STEEL OR GALVANIZED STEEL GROUND RODS ADD SUFFIX "-N" TO MOLD NUMBER.
  - FOR HEAVY DUTY MOLDS, MOLDS WITH WEAR PLATES OR MOLDS FOR COPPERWELD® CABLE, CONTACT THERMOWELD®.
  - FOR EXPEDITED SERVICE, CONTACT THERMOWELD®.
  - REQUIRED TOOLS;  
HANDLE CLAMPS W/ FLINT IGNITOR (SEE CHART FOR CORRECT HANDLES)  
38-0309-00 ~ FLINT IGNITOR
  - OTHER RECOMMENDED ACCESSORIES;  
38-3922-00 ~ MOLD CLEANING BRUSH  
38-0135-00 ~ CABLE CLEANING BRUSH  
38-0304-00 ~ FILE  
38-0330-00 ~ CABLE CLAMP

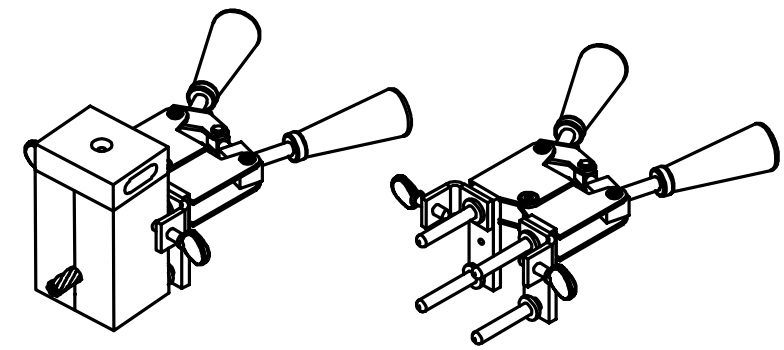
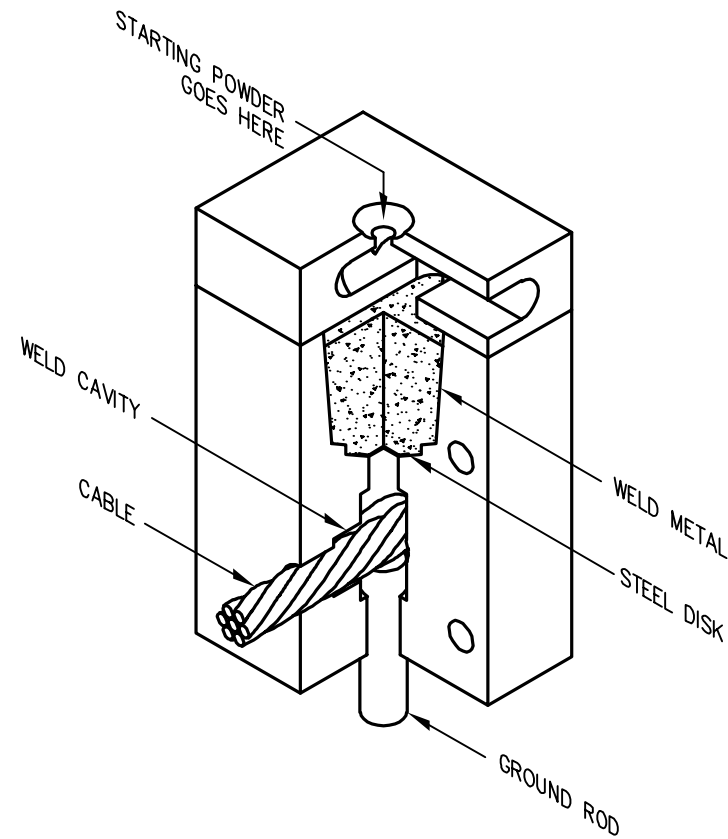

SHOWN WITH  
HANDLE CLAMPS

REF. B-106 / B-107  
HANDLE CLAMPS

thermOweld®

REV	EC #	DESCRIPTION	DATE	INITIALS
B	211203014949	TEMPLATE UPDATED	12/03/21	BE
A	2532	UPDATED HANDLE CLAMPS	11/15/12	BAM
REVISION HISTORY				

TO ORDER thermOweld® PRODUCTS CALL  UNITED STATES 1-800-558-1373  CANADA: 1-800-387-6487  FOR PRODUCT INFO: <a href="http://www.burndy.com">http://www.burndy.com</a>	SIGNATURES				
	DRAWN BY	DATE	APPROVED BY	DATE	
	K. DAVE	3/20/09	<i>KAC</i>	3/8/13	CR-2 TYPE MOLDS HORIZONTAL CABLE TO GROUND ROD
MATERIAL					SIZE: C DWG NO.: CD-0608 REV: B
SCALE: NTS					SHEET 1 OF 1