

REBAR SIZE	CABLE SIZE	MOLD #	PACKING MAT'L #	PRICE KEY	WELD METAL	HANDLE CLAMPS
#3	#6	M-7620	38-0329	24	90	B-106
	#4	M-7621	38-0329	24	90	B-106
	#2	M-7622	38-0329	24	90	B-106
	#1	M-7623	38-0329	24	115	B-106
	1/0	M-7624	38-0329	24	115	B-106
	2/0	M-7625	38-0329	24	115	B-106
	3/0	M-7626	38-0329	24	150	B-106
4/0	M-7627	38-0329	24	150	B-106	
#4	#6	M-7628	38-0329	24	90	B-106
	#4	M-7629	38-0329	24	90	B-106
	#2	M-7630	38-0329	24	90	B-106
	#1	M-7631	38-0329	24	115	B-106
	1/0	M-7632	38-0329	24	115	B-106
	2/0	M-7633	38-0329	24	115	B-106
	3/0	M-7634	38-0329	24	150	B-106
4/0	M-7635	38-0329	24	150	B-106	
#5	#6	M-7636	38-0329	24	90	B-106
	#4	M-7637	38-0329	24	90	B-106
	#2	M-7638	38-0329	24	90	B-106
	#1	M-7639	38-0329	24	115	B-106
	1/0	M-7640	38-0329	24	115	B-106
	2/0	M-7641	38-0329	24	115	B-106
	3/0	M-7642	38-0329	24	150	B-106
4/0	M-7643	38-0329	24	150	B-106	
#6	#6	M-7644	38-0329	24	90	B-106
	#4	M-7645	38-0329	24	90	B-106
	#2	M-7646	38-0329	24	90	B-106
	#1	M-7647	38-0329	24	115	B-106
	1/0	M-7648	38-0329	24	115	B-106
	2/0	M-7649	38-0329	24	115	B-106
	3/0	M-7650	38-0329	24	150	B-106
4/0	M-7651	38-0329	24	150	B-106	
#7 & LARGER	#6	M-7652	38-4063	4	90	B-106-41
	#4	M-7653	38-4063	4	90	B-106-41
	#2	M-7654	38-4063	4	90	B-106-41
	#1	M-7655	38-4063	4	115	B-106-41
	1/0	M-7656	38-4063	4	115	B-106-41
	2/0	M-7657	38-4063	4	115	B-106-41
	3/0	M-7658	38-4063	4	150	B-106-41
4/0	M-7659	38-4063	4	150	B-106-41	

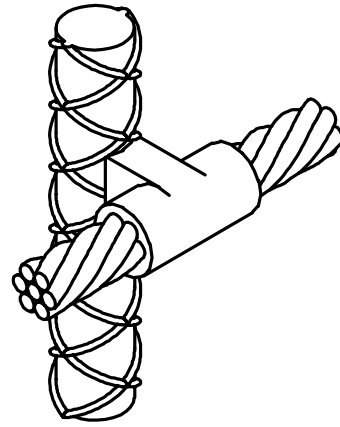

**CRE-3 TYPE MOLDS**  
HORIZONTAL THRU CABLE TO VERTICAL REBAR

CRE-3 TYPE MOLDS ARE RECOMMENDED FOR HORIZONTAL CONDUCTORS TO VERTICAL REBAR CONNECTIONS FOR SOLID OR CONCENTRIC STRANDED CONDUCTORS #6 THROUGH 4/0 JOINED TO REINFORCING BARS #3 THROUGH #7 & LARGER. THE HIGH COPPER CONTENT JOINT HAS A HIGHER CURRENT CARRYING CAPACITY THAN THE CONDUCTORS BEING JOINED AND IS IMPERVIOUS TO VIBRATION AND MOISTURE.

**NOTES:**

- FOR SIZES NOT LISTED, CONTACT THERMOWELD®.
- MOLDS LISTED ARE FOR CONCENTRIC STRANDED CABLE. ADD SUFFIX "-S" TO MOLD NUMBER FOR SOLID CONDUCTORS.
- FOR HEAVY DUTY MOLDS, MOLDS WITH WEAR PLATES OR MOLDS FOR COPPERWELD® CABLE, CONTACT THERMOWELD®.
- FOR EXPEDITED SERVICE, CONTACT THERMOWELD®.
- REQUIRED TOOLS:  
HANDLE CLAMPS W/ FLINT IGNITOR (SEE CHART FOR CORRECT HANDLES)  
38-0309-00 ~ FLINT IGNITOR
- OTHER RECOMMENDED ACCESSORIES:  
40-0319-03 ~ MOLD CLEANER FOR PK-4 MOLDS WITH CARTRIDGE SIZES #90-#500  
38-3922-00 ~ MOLD CLEANING BRUSH  
38-0135-00 ~ CABLE CLEANING BRUSH  
38-0304-00 ~ FILE

**PACKING MATERIAL NOTES:**

A PACKING PAD IS NECESSARY WHEN MAKING THERMOWELD® CONNECTIONS TO REBAR. PACKING MATERIAL 38-0329 IS A COPPER SHIM STOCK. PACKING MATERIAL NO.'S 38-4061, 38-4062 AND 38-4063 ARE A CERAMIC FIBER MATERIAL AND CAN BE USED FOR ONE CONNECTION ONLY. BE SURE TO SPECIFY PACKING MATERIAL NO. WHEN ORDERING MOLD AND WELD METAL.

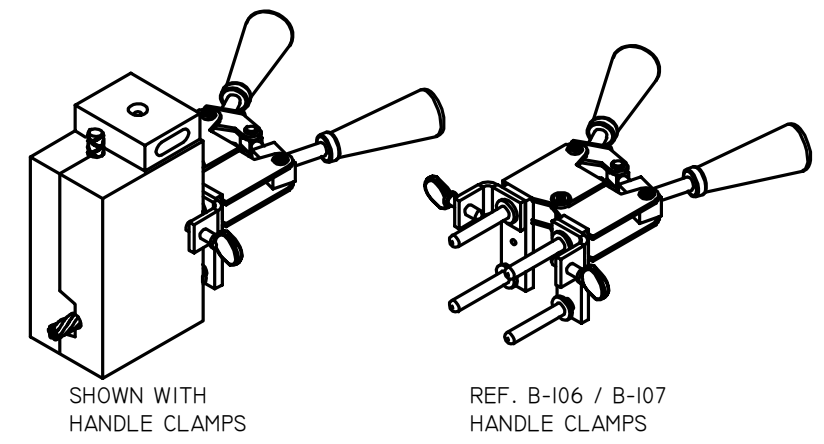
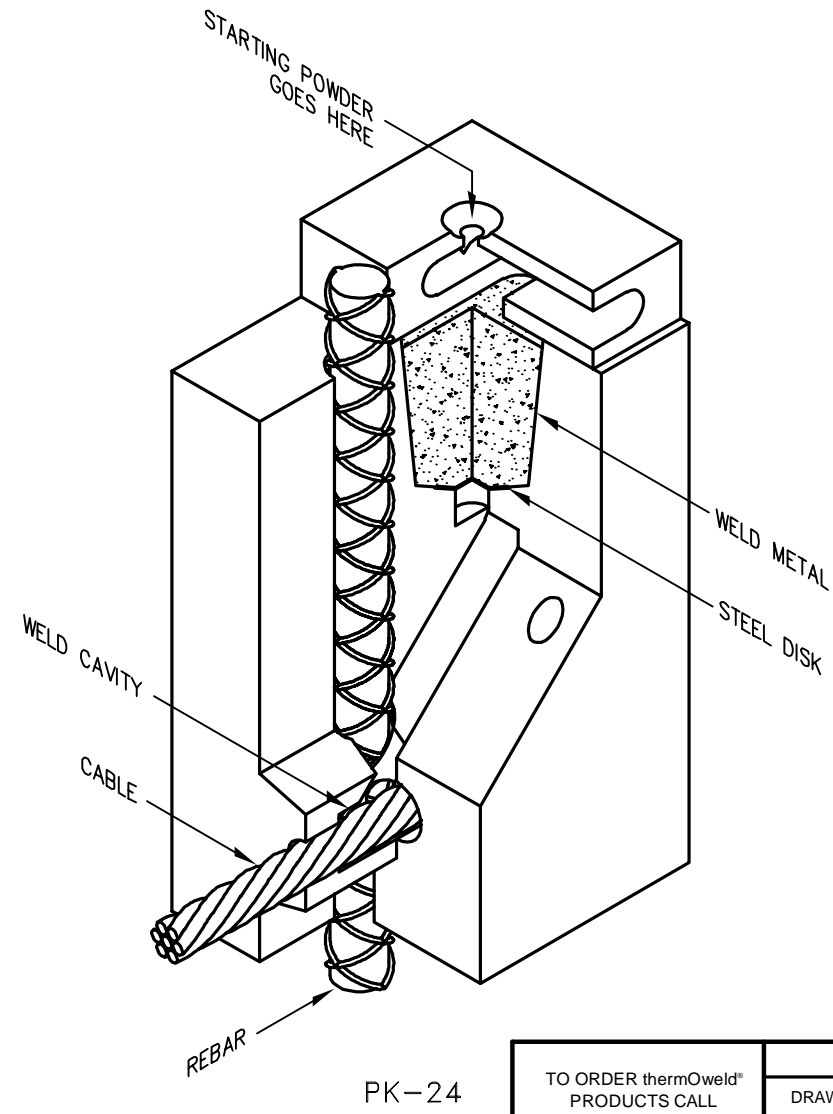
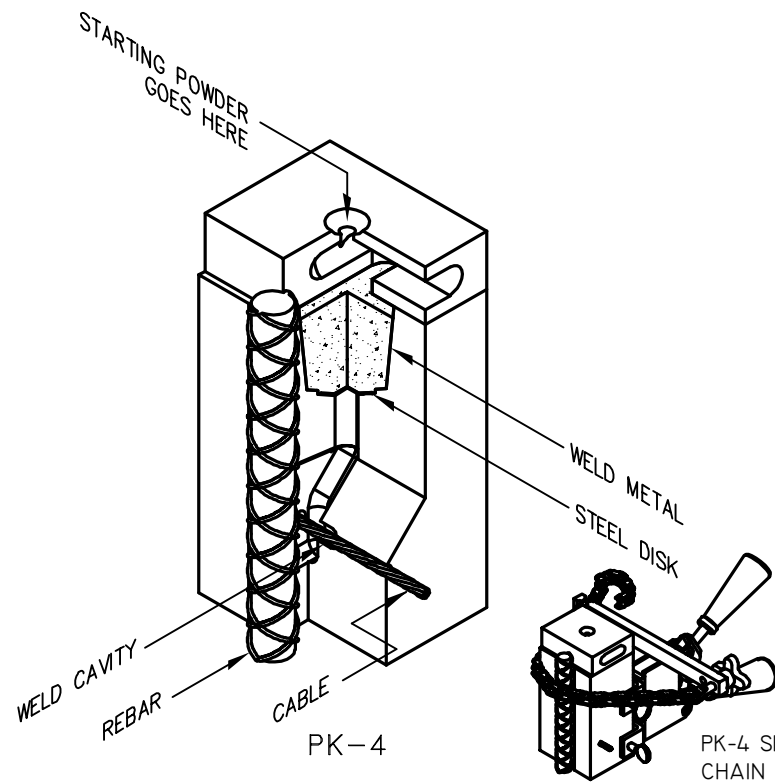

thermOweld®



CRE-3 TYPE MOLDS  
HORIZONTAL THRU CABLE TO VERTICAL REBAR

REV	EC #	DESCRIPTION	DATE	INITIALS
C	220103015638	TEMPLATE UPDATED	01/04/2022	BE
B	2532	UPDATED HANDLE CLAMPS	01/08/13	BAM

REVISION HISTORY

TO ORDER thermOweld® PRODUCTS CALL  
UNITED STATES  
1-800-558-1373  
CANADA:  
1-800-387-6487  
FOR PRODUCT INFO:  
<http://www.burndy.com>

SIGNATURES			
DRAWN BY	DATE	APPROVED BY	DATE
B. MCKASKLE	07/31/06	MAC	3/8/13
MATERIAL			

SIZE	DWG NO.	REV
C	CD-0642	C
SCALE	N.T.S.	SHEET 1 OF 1