

REBAR SIZE	CABLE SIZE	MOLD #	PACKING MAT'L #	PRICE KEY	WELD METAL	HANDLE CLAMPS
#3	#6	M-7708	38-0329	4	90	B-106
	#4	M-7709	38-0329	4	90	B-106
	#2	M-7710	38-0329	4	90	B-106
	#1	M-7711	38-0329	4	115	B-106
	1/0	M-7712	38-0329	22	115	B-106
	2/0	M-7713	38-0329	22	115	B-106
	3/0	M-7714	38-0329	22	150	B-106
#4	4/0	M-7715	38-0329	22	150	B-106
	#6	M-7716	38-0329	4	90	B-106
	#4	M-7717	38-0329	4	90	B-106
	#2	M-7718	38-0329	4	90	B-106
	#1	M-7719	38-0329	22	115	B-106
	1/0	M-7720	38-0329	22	115	B-106
	2/0	M-7721	38-0329	22	115	B-106
#5	3/0	M-7722	38-0329	22	150	B-106
	4/0	M-7723	38-0329	22	150	B-106
	#6	M-7724	38-0329	4	90	B-106
	#4	M-7725	38-0329	4	90	B-106
	#2	M-7726	38-0329	4	90	B-106
	#1	M-7727	38-0329	22	115	B-106
	1/0	M-7728	38-0329	22	115	B-106
#6 & LARGER	2/0	M-7729	38-0329	22	115	B-106
	3/0	M-7730	38-0329	22	150	B-106
	4/0	M-7731	38-0329	22	150	B-106
	#6	M-7732	38-4061	14†	90	INCLUDED
	#4	M-7733	38-4061	14†	90	INCLUDED
	#2	M-7734	38-4061	14†	90	INCLUDED
	#1	M-7735	38-4061	14†	115	INCLUDED
1/0	M-7736	38-4062	14†	115	INCLUDED	
2/0	M-7737	38-4062	14†	115	INCLUDED	
3/0	M-7738	38-4062	14†	150	INCLUDED	
4/0	M-7739	38-4062	14†	150	INCLUDED	

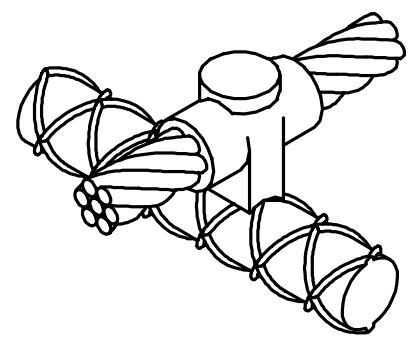

CRE-4 TYPE MOLDS
HORIZONTAL THRU CABLE TO HORIZONTAL REBAR

CRE-4 TYPE MOLDS ARE RECOMMENDED FOR HORIZONTAL THROUGH CONDUCTORS TO HORIZONTAL REBAR AT RIGHT ANGLE CONNECTIONS FOR SOLID OR CONCENTRIC STRANDED CONDUCTORS #6 THROUGH 4/0 JOINED TO REINFORCING BARS #3 THROUGH #6 & LARGER. THE HIGH COPPER CONTENT JOINT HAS A HIGHER CURRENT CARRYING CAPACITY THAN THE CONDUCTORS BEING JOINED AND IS IMPERVIOUS TO VIBRATION AND MOISTURE.

- NOTES:
- FOR SIZES NOT LISTED, CONTACT THERMOWELD®.
 - MOLDS LISTED ARE FOR CONCENTRIC STRANDED CABLE. ADD SUFFIX "-S" TO MOLD NUMBER FOR SOLID CONDUCTORS.
 - FOR HEAVY DUTY MOLDS, MOLDS WITH WEAR PLATES OR MOLDS FOR COPPERWELD® CABLE, CONTACT THERMOWELD®.
 - FOR EXPEDITED SERVICE, CONTACT THERMOWELD®.
 - REQUIRED TOOLS;
HANDLE CLAMPS W/ FLINT IGNITOR (SEE CHART FOR CORRECT HANDLES)
† ~ SOLD COMPLETE WITH HANDLE CLAMPS AND PK-14 ATTACHMENT
38-0309-00 ~ FLINT IGNITOR
 - OTHER RECOMMENDED ACCESSORIES;
40-0319-03 ~ MOLD CLEANER FOR PK-4 & 22 MOLDS WITH CARTRIDGE SIZES #90-#500
38-3922-00 ~ MOLD CLEANING BRUSH
38-0135-00 ~ CABLE CLEANING BRUSH
38-0304-00 ~ FILE

PACKING MATERIAL NOTES:
A PACKING PAD IS NECESSARY WHEN MAKING THERMOWELD® CONNECTIONS TO REBAR. PACKING MATERIAL 38-0329 IS A COPPER SHIM STOCK. PACKING MATERIAL NO.'S 38-4061, 38-4062 AND 38-4063 ARE A CERAMIC FIBER MATERIAL AND CAN BE USED FOR ONE CONNECTION ONLY. BE SURE TO SPECIFY PACKING MATERIAL NO. WHEN ORDERING MOLD AND WELD METAL.

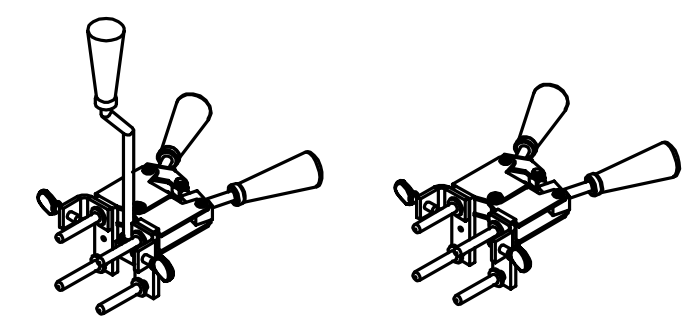
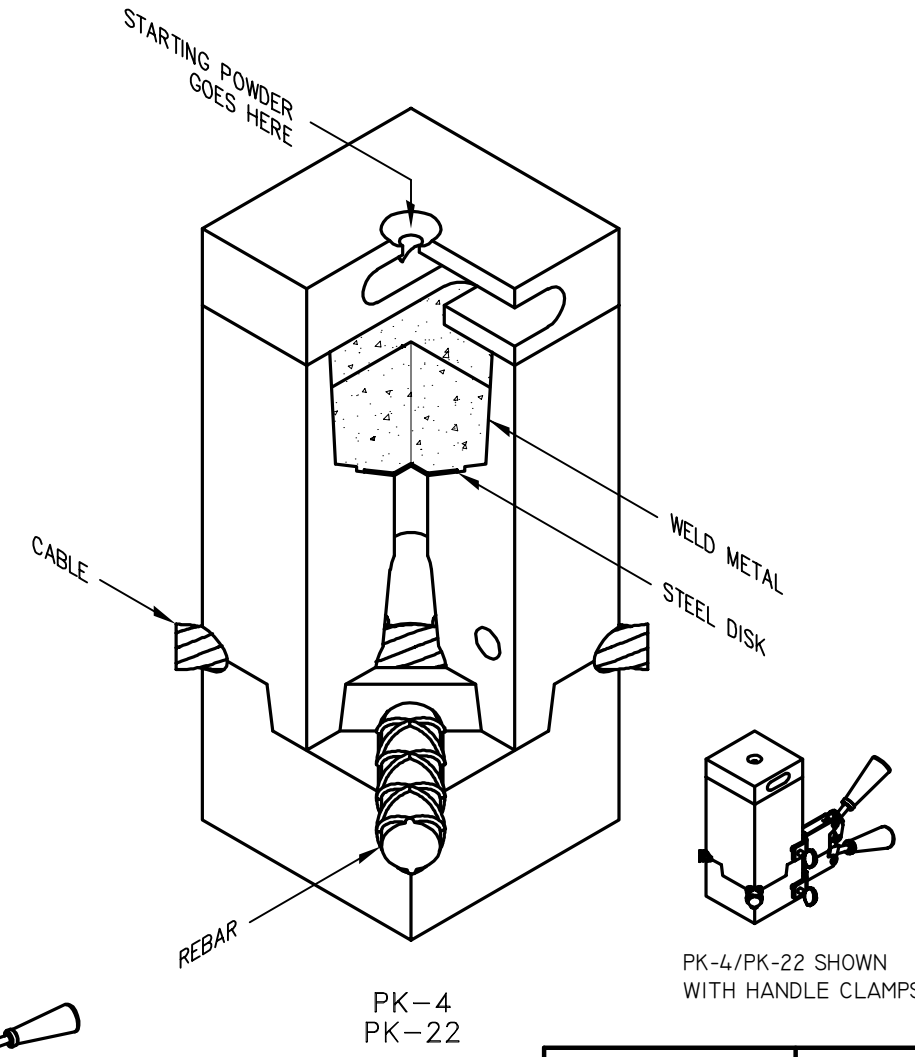
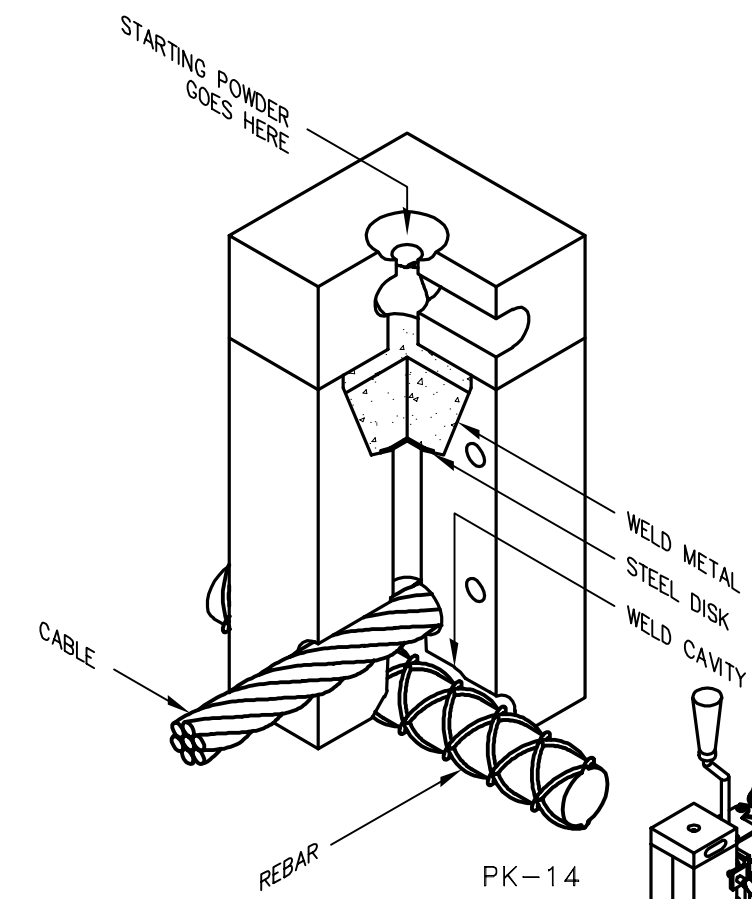

PK-4/PK-22 SHOWN WITH HANDLE CLAMPS REF. B-106 HANDLE CLAMPS WITH PK-14 ATTACHMENT REF. B-106 / B-107 HANDLE CLAMPS

thermOweld®

REV	EC #	DESCRIPTION	DATE	INITIALS
D	220103015638	TEMPLATE UPDATED	01/04/2022	BE
C	2532	UPDATED HANDLE CLAMPS	01/09/13	BAM

REVISION HISTORY

TO ORDER thermOweld® PRODUCTS CALL UNITED STATES 1-800-558-1373 CANADA: 1-800-387-6487 FOR PRODUCT INFO: http://www.burndy.com	SIGNATURES			
	DRAWN BY	DATE	APPROVED BY	DATE
	B. MCKASKLE	08/01/06	MAC	3/8/13
MATERIAL				

CRE-4 TYPE MOLDS HORIZONTAL THRU CABLE TO HORIZONTAL REBAR	
SIZE	DWG NO.
C	CD-0643
SCALE	SHEET 1 OF 1