

REBAR SIZE	CABLE SIZE	MOLD #	PACKING MAT'L #	PRICE KEY	WELD METAL	HANDLE CLAMPS
#3	#6	M-7884	38-4060	4	90	B-106
	#4	M-7885	38-4060	4	90	B-106
	#2	M-7886	38-4060	4	90	B-106
	#1	M-7887	38-4060	4	115	B-106
	1/0	M-7888	38-4060	4	115	B-106
	2/0	M-7889	38-4060	4	115	B-106
	3/0	M-7890	38-4060	4	150	B-106
#4	4/0	M-7891	38-4060	4	150	B-106
	#6	M-7892	38-4061	4	90	B-106
	#4	M-7893	38-4061	4	90	B-106
	#2	M-7894	38-4061	4	90	B-106
	#1	M-7895	38-4061	4	115	B-106
	1/0	M-7896	38-4060	4	115	B-106
	2/0	M-7897	38-4060	4	115	B-106
#5	3/0	M-7898	38-4060	4	150	B-106
	4/0	M-7899	38-4060	4	150	B-106
	#6	M-7900	38-4060	4	90	B-106
	#4	M-7901	38-4060	4	90	B-106
	#2	M-7902	38-4060	4	90	B-106
	#1	M-7903	38-4060	4	115	B-106
	1/0	M-7904	38-4060	4	115	B-106
#6	2/0	M-7905	38-4060	4	115	B-106
	3/0	M-7906	38-4060	4	150	B-106
	4/0	M-7907	38-4060	4	150	B-106
	#6	M-7908	38-4060	4	90	B-106
	#4	M-7909	38-4060	4	90	B-106
	#2	M-7910	38-4060	4	90	B-106
	#1	M-7911	38-4060	4	115	B-106
#7 & LARGER	1/0	M-7912	38-4060	4	115	B-106
	2/0	M-7913	38-4060	4	115	B-106
	3/0	M-7914	38-4060	4	150	B-106
	4/0	M-7915	38-4060	4	150	B-106
	#6	M-7916	38-4063	4	90	B-106-32
	#4	M-7917	38-4063	4	90	B-106-32
	#2	M-7918	38-4063	4	90	B-106-32
#7 & LARGER	#1	M-7919	38-4063	4	115	B-106-32
	1/0	M-7920	38-4063	4	115	B-106-32
	2/0	M-7921	38-4063	4	115	B-106-32
	3/0	M-7922	38-4063	4	150	B-106-32
	4/0	M-7923	38-4063	4	150	B-106-32

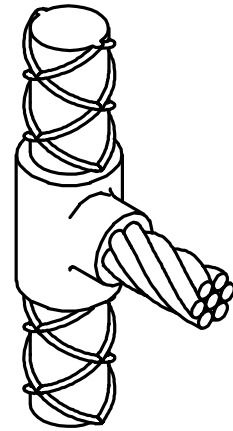

CRE-6 TYPE MOLDS
HORIZONTAL CABLE TAP TO VERTICAL REBAR

CRE-6 TYPE MOLDS ARE RECOMMENDED FOR HORIZONTAL CONDUCTORS TERMINATING AT RIGHT ANGLES TO VERTICAL REBAR CONNECTIONS FOR SOLID OR CONCENTRIC STRANDED CONDUCTORS #6 THROUGH 4/0 JOINED TO REINFORCING BARS #3 THROUGH #7 AND LARGER. THE HIGH COPPER CONTENT JOINT HAS A HIGHER CURRENT CARRYING CAPACITY THAN THE CONDUCTORS BEING JOINED AND IS IMPERVIOUS TO VIBRATION AND MOISTURE.

NOTES:

- FOR SIZES NOT LISTED, CONTACT THERMOWELD®.
- MOLDS LISTED ARE FOR CONCENTRIC STRANDED CABLE. ADD SUFFIX "-S" TO MOLD NUMBER FOR SOLID CONDUCTORS.
- FOR HEAVY DUTY MOLDS, MOLDS WITH WEAR PLATES OR MOLDS FOR COPPERWELD® CABLE, CONTACT THERMOWELD®.
- FOR EXPEDITED SERVICE, CONTACT THERMOWELD®.
- REQUIRED TOOLS:
HANDLE CLAMPS W/ FLINT IGNITOR (SEE CHART FOR CORRECT HANDLES)
38-0309-00 ~ FLINT IGNITOR
- OTHER RECOMMENDED ACCESSORIES:
38-3922-00 ~ MOLD CLEANING BRUSH
38-0135-00 ~ CABLE CLEANING BRUSH
38-0304-00 ~ FILE

PACKING MATERIAL NOTES:

A PACKING PAD IS NECESSARY WHEN MAKING THERMOWELD® CONNECTIONS TO REBAR. PACKING MATERIAL 38-0329 IS A COPPER SHIM STOCK. PACKING MATERIAL No.'s 38-4061, 38-4062 AND 38-4063 ARE A CERAMIC FIBER MATERIAL AND CAN BE USED FOR ONE CONNECTION ONLY. BE SURE TO SPECIFY PACKING MATERIAL No. WHEN ORDERING MOLD AND WELD METAL.

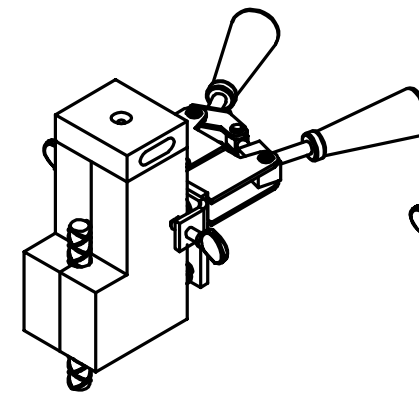
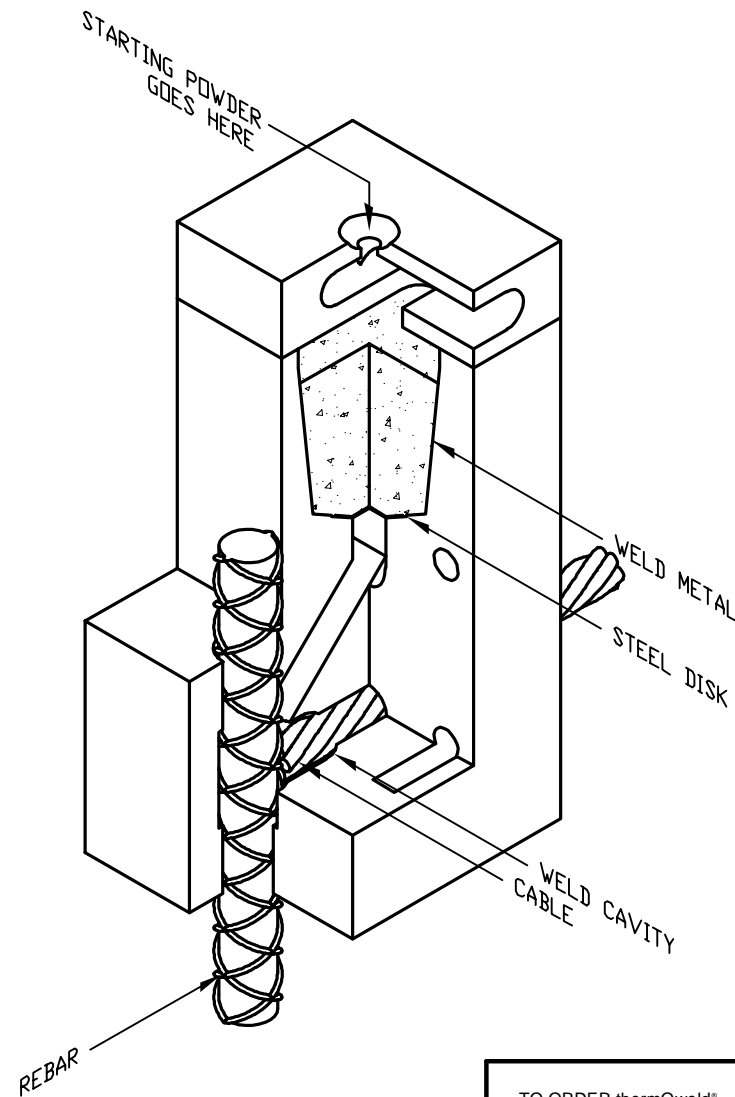

SHOWN WITH
HANDLE CLAMPS

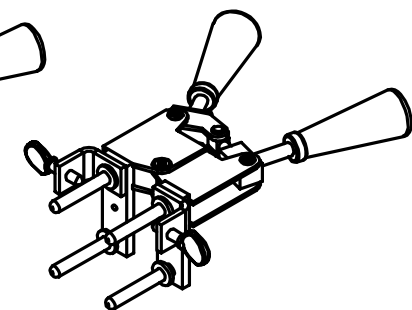

REF. B-106 / B-107
HANDLE CLAMPS

thermOweld®

REV	EC #	DESCRIPTION	DATE	INITIALS
C	220103015638	TEMPLATE UPDATED	01/04/2022	BE
B	2532	UPDATED HANDLE CLAMPS	01/09/13	BAM

REVISION HISTORY

TO ORDER thermOweld® PRODUCTS CALL UNITED STATES 1-800-558-1373 CANADA: 1-800-387-6487 FOR PRODUCT INFO: http://www.burndy.com	SIGNATURES				
	DRAWN BY	DATE	APPROVED BY	DATE	
	B. MCKASKLE	07/28/06	<i>MAC</i>	3/8/13	
MATERIAL					CRE-6 TYPE MOLDS HORIZONTAL CABLE TAP TO VERTICAL REBAR TO VERTICAL STEEL
SIZE	DWG NO.			REV	
C	CD-0644			C	
SCALE	N.T.S.			SHEET 1 OF 1	