

TRANSFORMER SPECIFICATIONS	
PRIMARY VOLTAGE(S)	550/575/600
SECONDARY VOLTAGE(S)	110/115/120
RATED V.A.	250
RATED FREQUENCY	50/60
INSULATION CLASS	130°C @ MAX RISE 80°C
AGENCY APPROVALS	UL, CUL
ESTIMATED WEIGHT	10 LBS

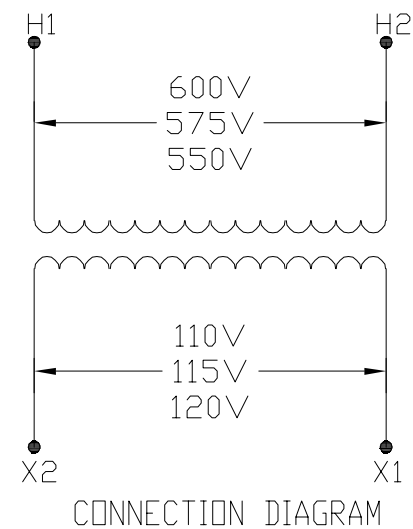

DIMENSIONS ARE IN INCHES TOLERANCES: .XX ± .03 .XXX ± .010 ANGULAR: ± 1°	DRAWN BY:	VS	DATE	06/05/2020
	CHECKED BY:			
SOURCE	N/A	PROPRIETARY AND CONFIDENTIAL THE INFORMATION CONTAINED IN THIS DRAWING IS THE SOLE PROPERTY OF ACME ELECTRIC. ANY REPRODUCTION IN PART OR AS A WHOLE WITHOUT THE WRITTEN PERMISSION OF ACME ELECTRIC IS PROHIBITED.		
MATERIAL	N/A			
FINISH	N/A			
DO NOT SCALE DRAWING		DESCRIPTION: 250 VA		
		SIZE DWG. NO.	A CE250N017	
		WEIGHT:	LBS.	SHEET 1 OF 1

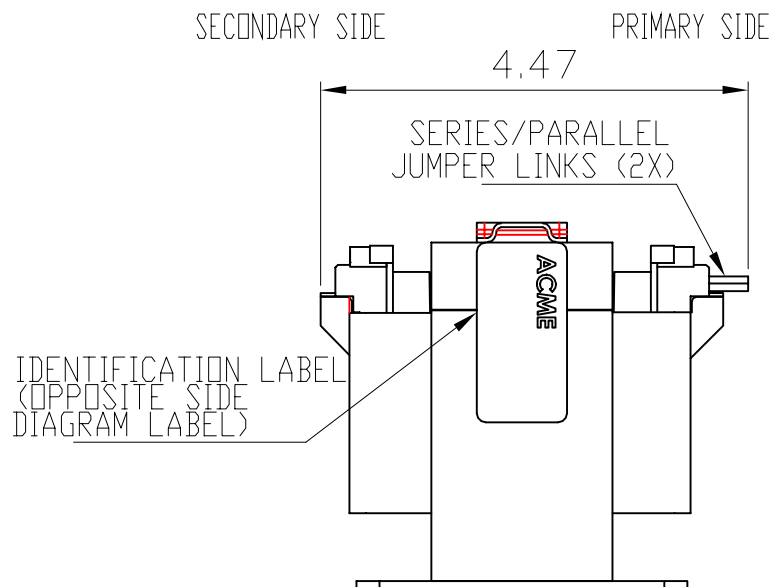
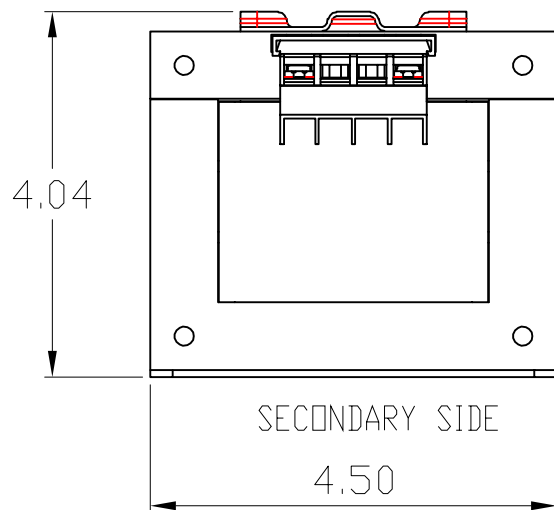