

TRANSFORMER SPECIFICATIONS	
PRIMARY VOLTAGE(S)	240x480
SECONDARY VOLTAGE(S)	120x240
RATED V.A.	750
RATED FREQUENCY	50/60
INSULATION CLASS	130°C @ MAX RISE 80°C
AGENCY APPROVALS	UL, CUL
ESTIMATED WEIGHT	28.1 LBS

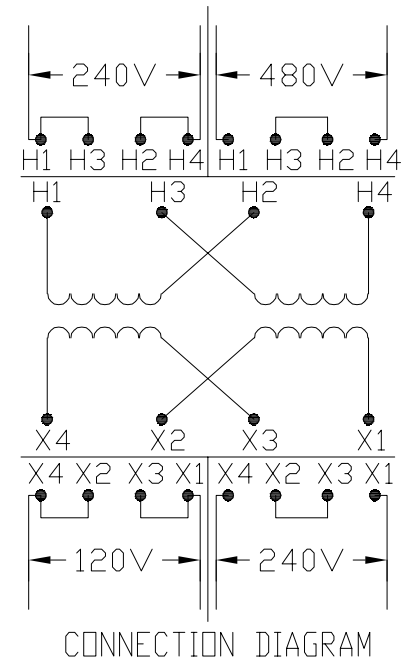

DIMENSIONS ARE IN INCHES TOLERANCES: .XX ± .03 .XXX ± .010 ANGULAR: ± 1°	DRAWN BY:	VS	DATE	06/08/2020
	CHECKED BY:			
SOURCE	N/A	PROPRIETARY AND CONFIDENTIAL		
MATERIAL	N/A	THE INFORMATION CONTAINED IN THIS DRAWING IS THE SOLE PROPERTY OF ACME ELECTRIC. ANY REPRODUCTION IN PART OR AS A WHOLE WITHOUT THE WRITTEN PERMISSION OF ACME ELECTRIC IS PROHIBITED.		
FINISH	N/A			
DO NOT SCALE DRAWING				

DESCRIPTION: 750 VA	
SIZE DWG. NO.	CE750N014
WEIGHT:	LBS.
SHEET 1 OF 1	