

DRAWING NO.
CSC012568-01

REV	DATE	DESCRIPTION	ECO	BY	C'H'K.
A	09/23/2014 00:00:00 AM	DRAWING RELEASED	37921	MM	SP

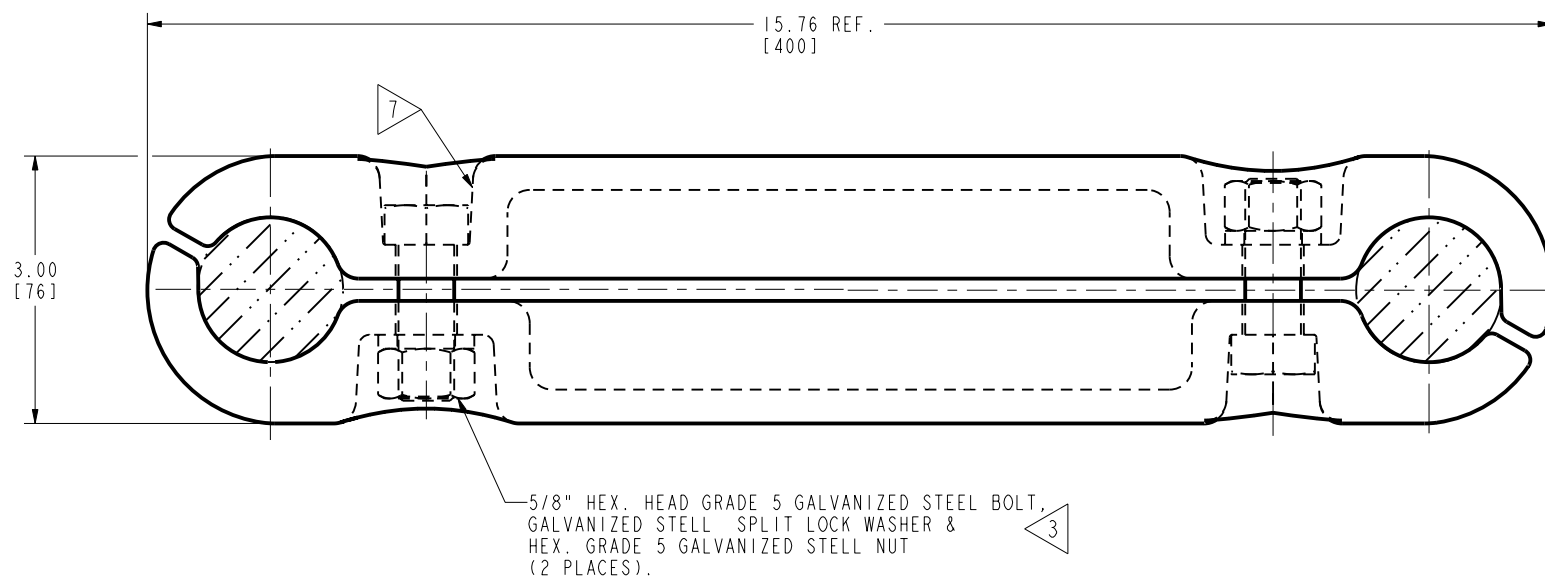
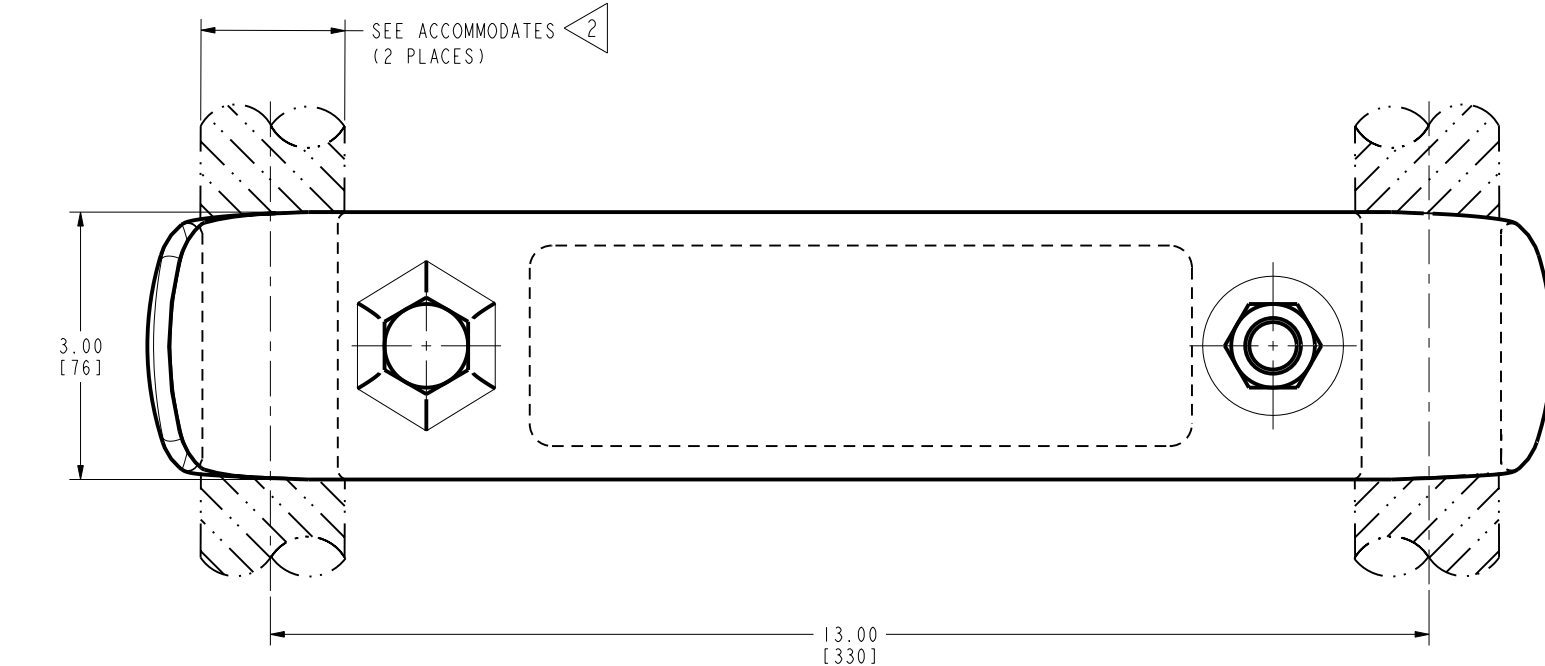

- NOTES:
- MATERIAL:
CAST ALUMINUM ALLOY
 - ACCOMMODATES:
(2) 1843.2 Kcmil (1.600 [41] DIA.) ACSR.
 - NOMINAL BOLT INSTALLATION TORQUE:
5/8" GRADE 5 GALVANIZED STEEL HARDWARE - 660 LB-IN [75 Nm]
 - DIMENSIONS IN BRACKETS [] DENOTES METRIC UNITS [SI UNITS] AND ARE ROUNDED TO THE NEAREST WHOLE NUMBER. UNLESS OTHERWISE SPECIFIED THESE UNITS SHALL BE USED FOR REFERENCE ONLY.
 - PENETROX™ NOTE: SCRATCH BRUSH CONNECTOR CONTACT SURFACE DRY, THEN APPLY PENETROX™ A. PENETROX™ CAN BE PURCHASED FROM BURNDY LLC. IN CANS OR PLASTIC SQUEEZE BOTTLES.
 - THE CONCEPT SHOWN INCORPORATES PRINCIPLES WHICH PERMIT OPERATION AT A VOLTAGE GRADIENT NORMALLY ASSOCIATED WITH 735 KV RMS OPERATION PHASE TO PHASE.
 - HEX BOLTS CAPTURED TO PREVENT TURNING DURING INSTALLATION.
 - MARKING:
BURNDY
S2R59RCG1
1843.2 Kcmil ACSR
500 KVDC

TO ORDER BURNDY® PRODUCTS CALL		STREAMLINED RIGID SPACER, EHV	
UNITED STATES		ITEM NO: 10082671	
1-800-346-4175 (LONDONDERRY, NH)		CAT. NO: S2R59RCG1	
CANADA:		DRAWN BY: M MOHAN 09/23/14	
1-800-361-6975 (QUEBEC)		CHECKER: S PANDIAN 09/23/14	
1-800-387-6487 (ALL OTHER PROVINCES)		DSN APPVL: R LAVOIE 10/01/14	
FOR PRODUCT INFO: http://www.burndy.com		MFG APPVL: T WAWRZYNIAK 10/02/14	
		QA APPVL: J HILLMAN 10/01/14	
		MKT APPVL: V TORRES 10/01/14	
		SCALE: 1:1	
		PROJ FAM: SUBSTATION	DRAWING NO
		PROJECT #: --	CSC012568-01
		DOCUMENT TYPE: Sales	REV
		REL LEVEL: Released	A

REV: PEO200