

DRAWING NO.  
**CSD29130**

7 6 5 4 3 2 1

FLEX CABLE SIZE	CATALOG NUMBER	STUD SIZE	DIMENSIONS IN INCHES							INSTALLATION TOOLING HYPRESS			
			O.D.	N ±.025	Z ±.025	L ±.030	B ±.030	C ±.025	T ±.005	Y35 <sup>1</sup>	Y39 <sup>1</sup>	Y46 <sup>2</sup>	Y46
										NEST	INDENTOR	NEST	INDENTOR
8 AWG	YAV8T38B	3/8	.270	.281	.399	1.320	.445	.570	.060	U8CD-1C	Y34PL	-----	
6 AWG	YAV6T38B	3/8	.340	.406	.422	1.755	.690	.577	.078	U4CD-1C	Y34PL	-----	
4 AWG	YAV4T38B	3/8	.415	.406	.422	1.765	.675	.605	.109	U2CD-1C	Y34PR2	-----	
2 AWG	YAV2T38B	3/8	.461	.344	.359	1.700	.700	.680	.103	U1CD-1C	Y34PR2	-----	
1 AWG	YAV1T38B	3/8	.513	.406	.460	1.800	.685	.752	.120	U25D-1C	Y34PR2	-----	
1/0 KCMIL	YAV1/OT38B	3/8	.563	.406	.422	1.885	.680	.823	.115	U26D-1C	Y34PR2	-----	
2/0 KCMIL	YAV2/OT12B	1/2	.615	.406	.423	2.200	.740	.910	.125	U27D-1C	Y34PR2	-----	
3/0 KCMIL	YAV3/OT12B	1/2	.688	.530	.570	2.220	.735	1.015	.141	U28D-1C	Y34PR2	-----	
4/0 KCMIL	YAV4/OT12B	1/2	.750	.531	.547	2.390	.875	1.105	.155	U29D-1C	Y34PR2	-----	
262 KCMIL	YAV262T12B	1/2	.813	.531	.547	2.480	.930	1.199	.163	U30D-1C	Y34PR2	-----	
313 KCMIL	YAV313T12B	1/2	.953	.656	.672	2.775	1.020	1.403	.191	U32D-1C	Y34PR2	-----	
373 KCMIL	YAV373T58B	5/8	1.060	.656	.672	3.130	1.215	1.520	.226	U34D-1C	Y34PR2	-----	
444 KCMIL	YAV444T58B	5/8	1.178	.850	.869	3.680	1.380	1.690	.255	-----	P36D	P48PR1	
535 KCMIL	YAV535T58B	5/8	1.250	.875	.875	4.319	1.844	1.810	.265	-----	P38D	P48PR1	
646 KCMIL	YAV646T58B	5/8	1.490	.940	1.180	4.825	1.750	2.190	.318	-----	P44DC	P48PR1	
777 KCMIL	YAV777T58B	5/8	1.490	.940	1.180	4.825	1.750	2.190	.318	-----	P44DC	P48PR1	
444 KCMIL	YAV444T12B	1/2	1.178	.850	.869	3.680	1.380	1.690	.255	-----	P36D	P48PR1	

REV.	DATE	DESCRIPTION	ECO	BY	C'K'D.
D	03/19/08	C36 BARREL REDUCTION CHANGES BACK	15552	RB	RB

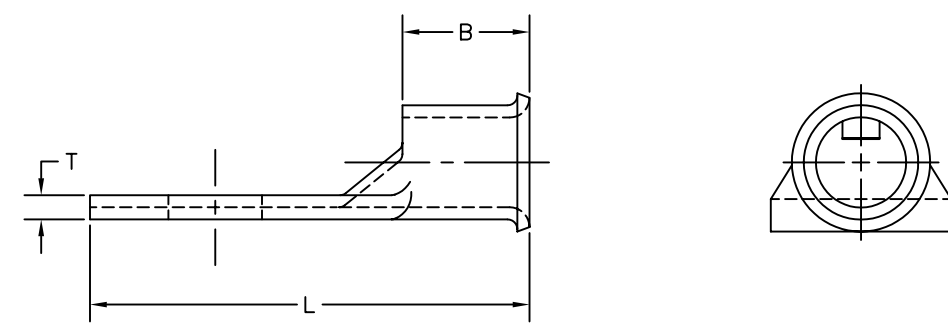
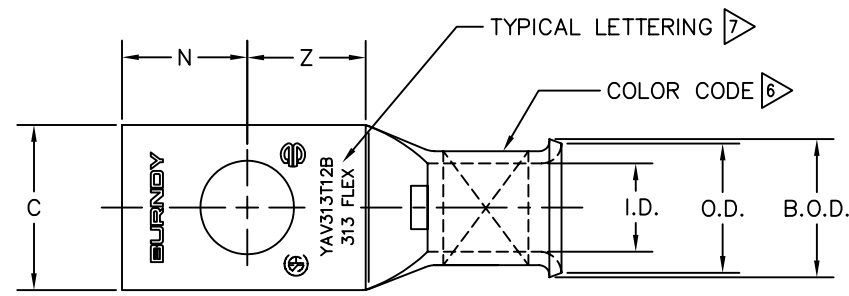

- NOTES:
- 1 USED WITH Y35P3 INDENTOR ADAPTOR
  - 2 USED WITH P-UADP ADAPTOR AND Y35P3
  - 3 MATERIAL: PURE ELECTROLYTIC SEAMLESS COPPER TUBE
  - 4 FINISH: TIN PLATING TO BURNDY SPEC F4383 TYPE T3
  - 5 ACCOMODATES: FLEXIBLE AND EXTRA FLEXIBLE COPPER CABLE SIZES AS SHOWN
  - 6 COLOR CODED IN BLACK INDENTOR AND/OR NEST DIE WITH BURNDY LOGO AS CRIMP TARGET
  - 7 CATALOGUE # AND WIRE SIZE STAMPED ON THE PAD

SUPERCEDES CSKD29130 REV.1

TO ORDER BURNDY®PRODUCTS CALL 1-800-346-4175  
MANCHESTER, NH 03109, USA  
FOR PRODUCT INFO = <http://www.fciconnect.com>

**HYLUG,™ SKIVED BACK BELLED**

ITEM NO: ---

CAT NO: TYPE YAV-----B TABLE

SCALE: NTS	
DRAWN BY: A.GREEN	4-15-91
CHECKER: H.GILL	4-15-91
DSN APPVL: ---	---
MFG APPVL: ---	---
QC APPVL: ---	---
MKT APPVL: ---	---
PROD FAM: ---	---
PROJECT #: ---	---
DOCUMENT TYPE: ---	---
REL LEVEL: ---	---

**BURNDY PRODUCTS**

DRAWING NO	REV
CSD29130	D
SHEET 1 OF 2	

8 7 6 5 4 3 2 1