

600 Amp Universal Air Bushing



Technical Data

Indoor and Outdoor Applications

Cycloaliphatic Epoxy

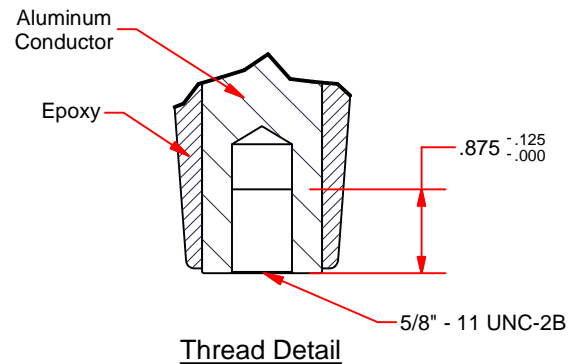
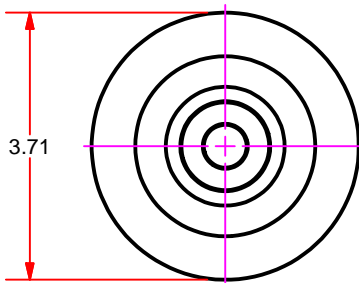
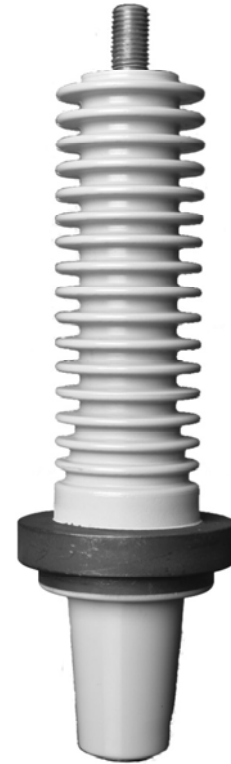
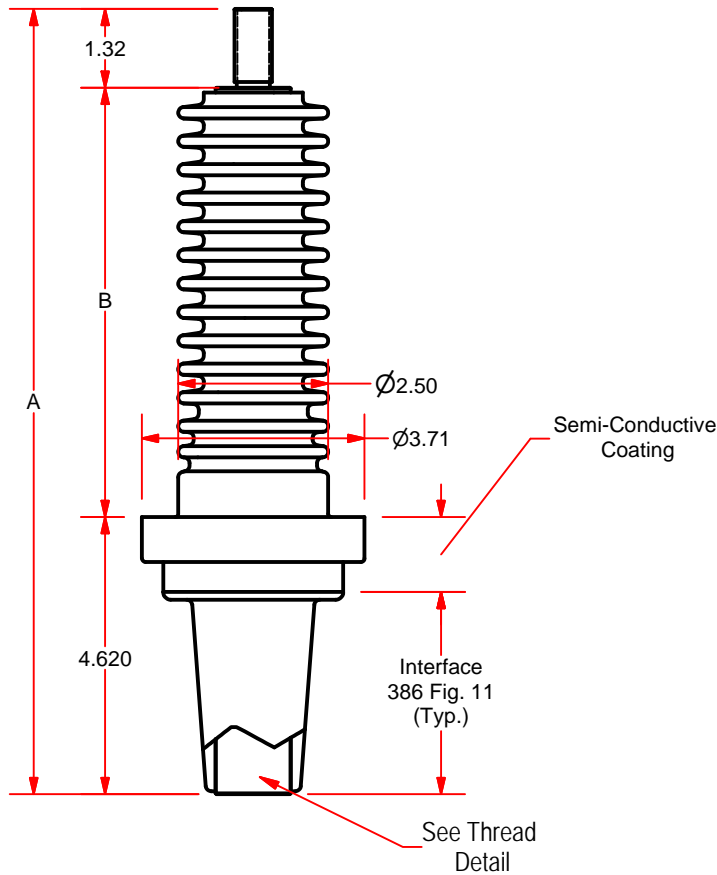

Part Number	Dimensions (in.)		Voltage Class(kV)	BIL (kV)	Electrical Ratings			Leakage Distance (in.)	Current Capacity (RMS)		Momentary Withstand (RMS / ASYM)		Approx. Weight
	A	B			Withstand 1 Min. 60 Hz Dry (kV)	Withstand 10 Sec. 60 Hz Wet (kV)	Corona Extinction		Continuous	8 Hr. Overload	10 Cycles	3 Seconds	
U-UAB95	13.09"	7.16"	15	95	34	53	11	15.07	600 Amps	900 Amps	25,000 Amps	10,000 Amps	3.50
U-UAB125	14.59"	8.66"	25	125	40	78	19	19.04	600 Amps	900 Amps	25,000 Amps	10,000 Amps	4.25

1.- Reuel 600 Amp 15kV and 25kV deadbreak apparatus bushings meet all requirements of ANSI/IEEE Standard 386. The bushings are designed for cover of sidewall mounting in transformers, switchgear, and other air insulated apparatuses.



PCORE Electric Co., Inc.
200 West Dewey St.
Goldsboro, NC 27530

Phone: +1.919.734.0460
Fax: +1.919.734.0902
www.hubbellpowersystems.com

Data Sheet DSUAB-01
19 October 2015