

ITEM	DESCRIPTION	MATERIAL
1	GROUND BLOCK ASSEMBLY	BRASS-MATTE TIN PLATED
2	1/4-20 UNC SLOTTED SET SCREW	STAINLESS STEEL

.450 TYP
[11.430]

#8-32 UNC X THRU 2-PLCS

.375
[9.525]

Ø.250 THRU 6-PLCS

.500
[12.700]

3.650
[92.710]

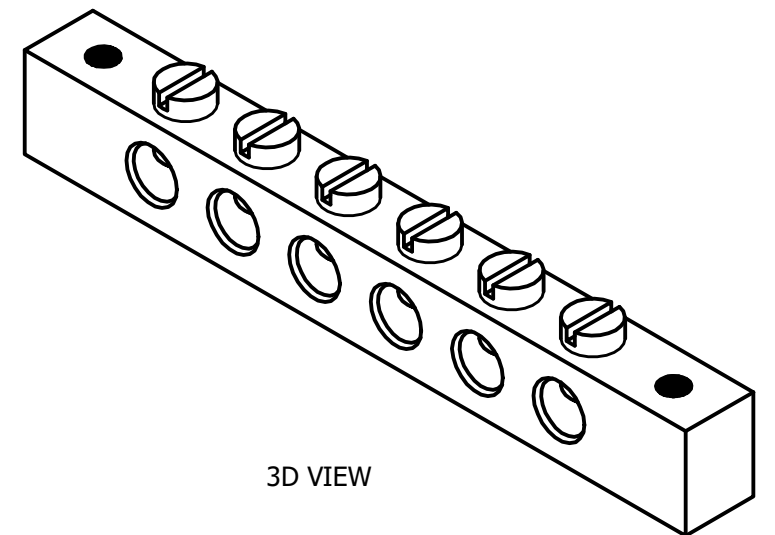

3D VIEW

- NOTES:**
- ALL DIMENSIONS FOR REFERENCE ONLY.
DISTANCE IN. [MM], FORCE LBS. [kN], TORQUE IN. LBS. [N.m], & WEIGHT LBS. [KG].
 - MATERIAL: SEE TABLE
 - CABLE RANGE: #32 AWG (DIA. 0.008 [0.2032]) MIN-
#8 AWG (DIA. 0.1285 [3.2639]) MAX

-		PREM	SP	SP		HUBBELL POWER SYSTEMS, Inc.
EC #	DATE	CHANGED BY	CHECKED BY	APPROVED BY		
EC DESCRIPTION:				WEIGHT (lbmass)	CONFIDENTIAL: THIS DRAWING AND ITS CONTENTS ARE CONFIDENTIAL AND THE EXCLUSIVE PROPERTY OF HUBBELL POWER SYSTEMS. NO PUBLICATION, DISTRIBUTION OR COPIES MAY BE MADE WITHOUT THE WRITTEN CONSENT OF HUBBELL POWER SYSTEMS. HUBBELL POWER SYSTEMS UNPUBLISHED ALL RIGHTS RESERVED UNDER THE COPYRIGHT LAWS	TITLE
				0.188		GROUND BLOCK ASSEMBLY
ADDITIONAL COMMENTS:						CATALOG NUMBER: EM-4250-6SSOMMC
SIZE	DWG NO.	PART / ASSY NO.		REV		
B	EM-4250-6SSOMMC-CC	EM-4250-6SSOMMC		A		
SCALE: NTS	DRN BY: PREM	DATE: 9/29/2023	SHEET 1 OF 1			