

INSULATION:  
1 1/2 [38] THICK

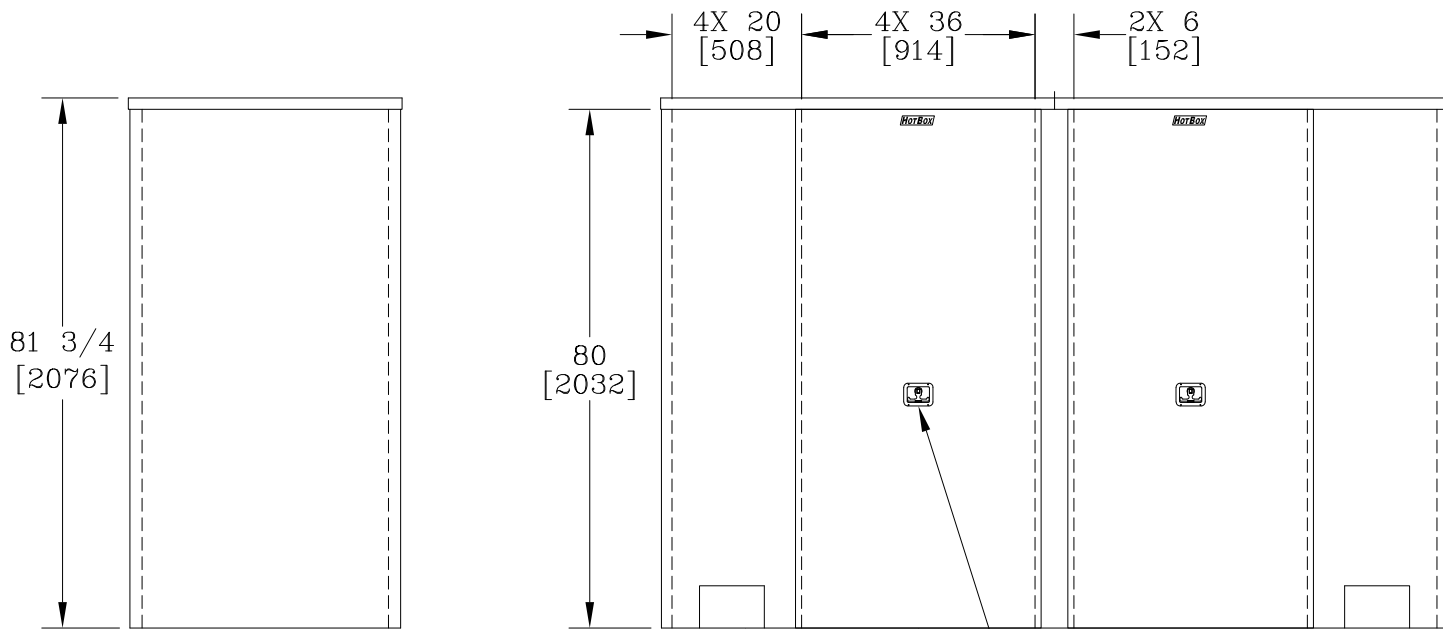

10 [254] X 6 1/2 [165]  
DRAINPORT (4 PLACES)

LOCKABLE HANDLE  
36 [914] X 80 [2032]  
REMOVABLE ACCESS PANEL  
4 PLACES

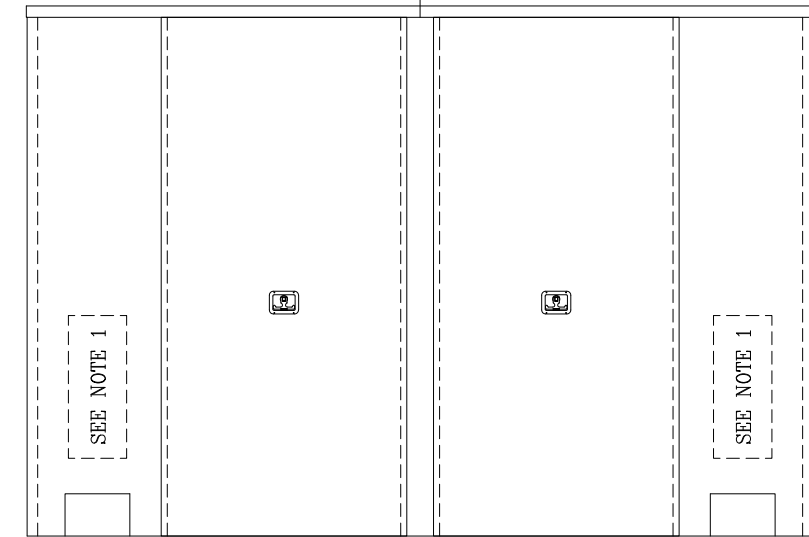

NOTES:

- HEAT IS PROVIDED BY (2) 1500W, 120V SINGLE PHASE HEATERS. FOR UNHEATED VERSION REPLACE THE PREFIX "H" WITH AN "L".
- FOR RECOMMENDED SLAB SIZE ADD 12" [305] TO THE ENCLOSURE INTERIOR.

DIMENSIONS ARE IN INCHES OR MILLIMETERS IN BRACKETS UNLESS OTHERWISE NOTED.						
DRN	BY	DATE	WEIGHT	 3621 INDUSTRIAL PARK DR LENOIR CITY, TN 37771 800-346-3062 www.hot-box.com	LOC	
CHK	ENG	APR	280# 127kg		LC	
APR	APR	APR	SCALE	DRAWING DESCRIPTION <b>HOT BOX® MODULAR</b> <b>ALUMINUM ENCLOSURE</b> <b>HBM8E</b>	REV	
			NTS		A	
			SIZE		9/18	
PROJECT NUMBER					DRAWING NUMBER	
					HK038118080	
				SHEET 1 OF 1		