

ITEM NO.	DESCRIPTION	QTY.
1	SC CONNECTOR DUST CAP	2
2	SC CONNECTOR BODY	2
3	SC DUPLEX CLIP	1
4	1.8mm SC CONNECTOR BOOT	2
5	1.8mm DUPLEX CABLE	A/R
6	1.8mm ST CONNECTOR BOOT	2
7	ST CONNECTOR NUT	2
8	ST CONNECTOR DUST CAP	2

CATALOG NUMBER	DESCRIPTION
DFPSTSC6MM	62.5/125um ST-SC DUPLEX CORD

"X" = 1 THRU 25 METERS

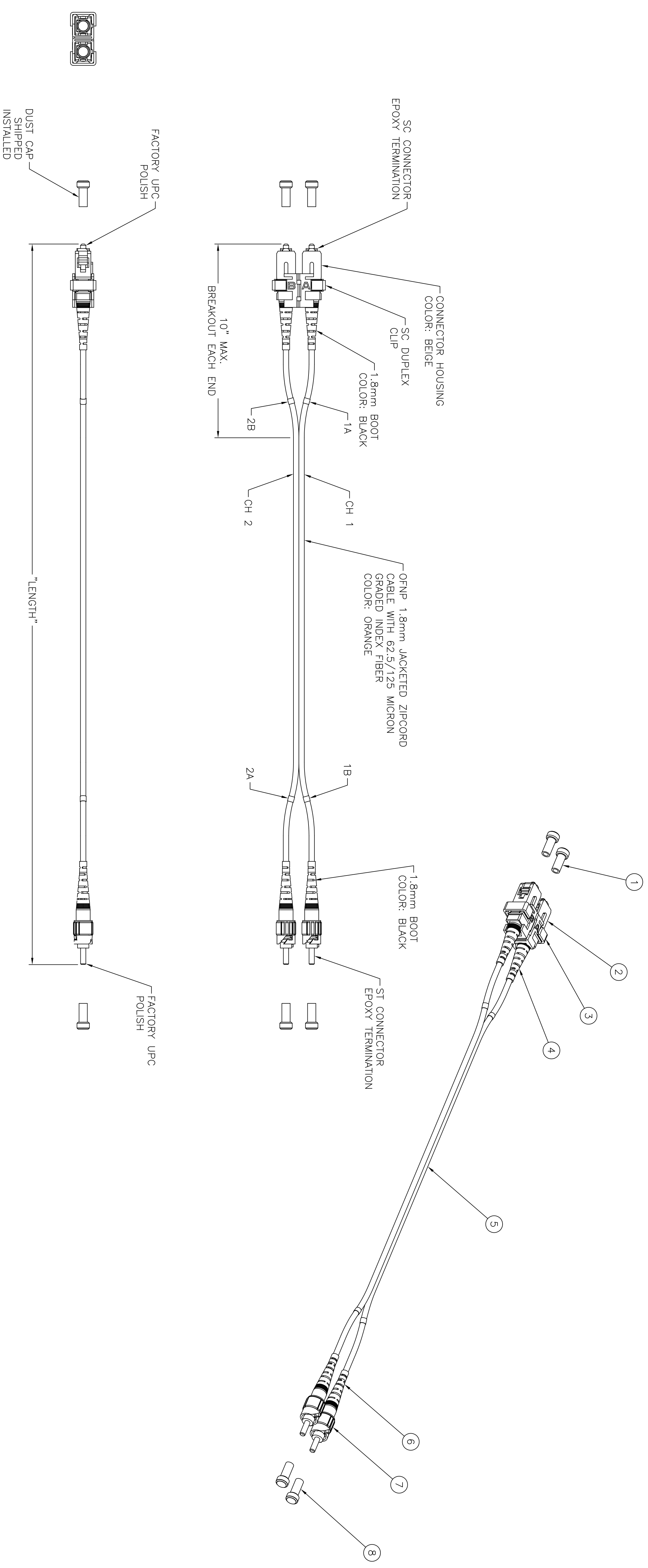

NOTES:

- CONNECTOR OPTICAL, MECHANICAL AND ENVIRONMENTAL PERFORMANCE MEETS TIA/EIA-568-B.3 SPECIFICATIONS.
- CONNECTOR USES A PC RADIUS TIP ZIRCONIA CERAMIC FERRULE.
- SC CONNECTOR HOUSING IS INJECTION MOLDED ENGINEERING PLASTIC RESIN. ST CONNECTOR NUT IS NICKEL PLATED ZINC DIE CAST.
- OPTICAL INSERTION LOSS TEST DATA INCLUDED IN EACH BAGGED PATCH CORD.
- CABLE MARKINGS TO IDENTIFY CHANNEL (1 OR 2) AND EACH END (A OR B).
- SPECIFICATIONS SUBJECT TO CHANGE WITHOUT PRIOR NOTICE.

REV.	EGN	DATE	DESCRIPTION	CHG BY	APPD BY
C	18030	01/11/13	REVISED CABLE TO PLENUM; ADDITIONAL LENGTHS	MMA	

Created on AUTOCAD		DIMENSIONING AND TOLERANCE PER ANSI Y14.5M-1982 UNLESS OTHERWISE SPECIFIED, DIMENSIONS ARE IN INCHES (MM). XX = ±.01 (.25) XXX = ±.005 (.127) XXXX = ±.0025 (.0635) ANGLE TOL. ±1°	
PROJECT REFERENCE:		MATERIAL:	
DRAWN BY: PAUL S. MAQUIRE 02/14/03		CHECKED BY: CINDY TALBOT 04/24/03	
APPROVED BY: CINDY TALBOT 04/24/03		TITLE: FIBER PATCH CORDS	
SIZE: DRAWING NO. D 10870C		HUBBELL Hubbell Premise Wiring HUBBELL INCORPORATED (Delaware) 141 Lord's Hill Road, Stonington, Connecticut 06378	
SCALE: 1/1		SHEET 1 OF 1	
REV. C			