

ITEM NO.	DESCRIPTION	QTY.
1	ST CONNECTOR DUST CAP	1
2	ST CONNECTOR NUT	1
3	ST CONNECTOR BOOT	1
4	900um BUFFERED CABLE	A/R

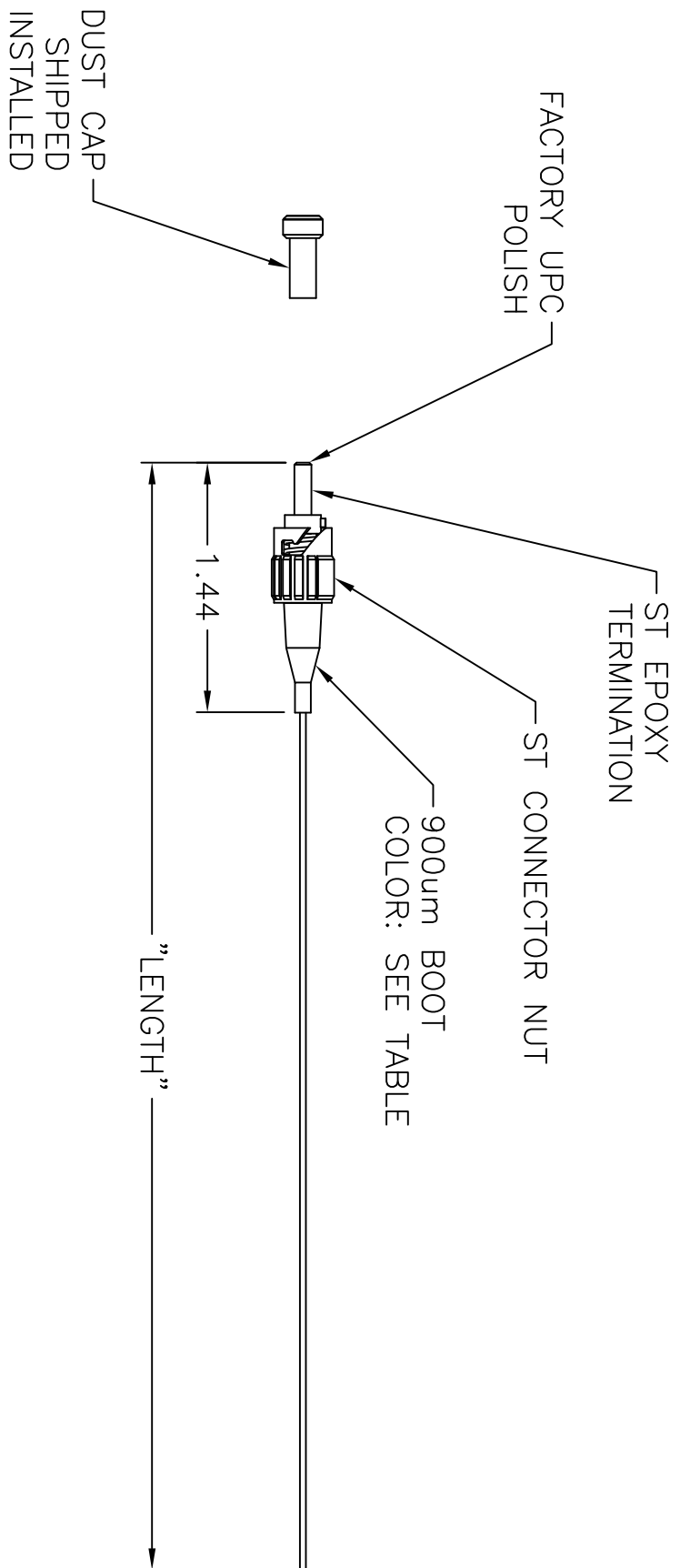
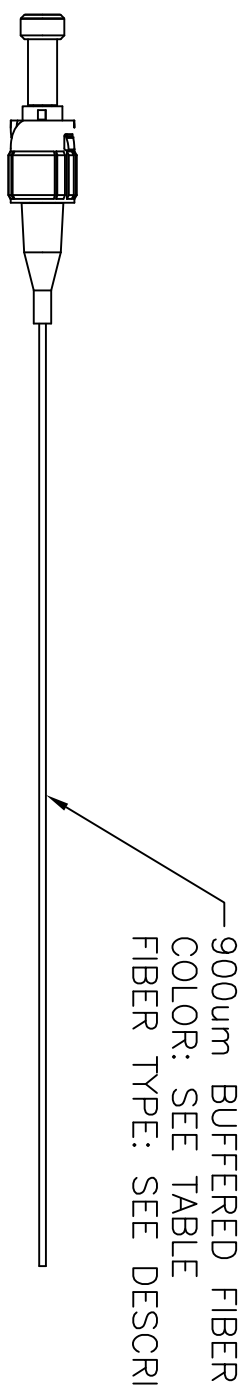
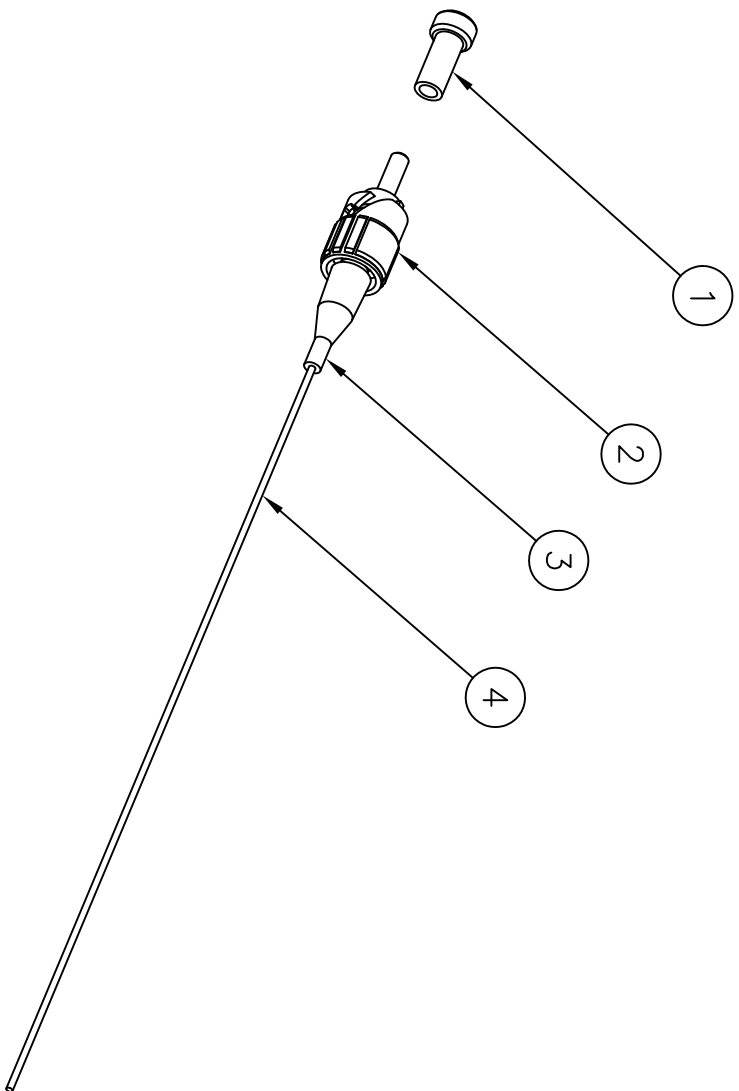

CATALOG NO.	DESCRIPTION	LENGTH	BUFFER COLOR	BOOT COLOR
FPSTC3MM	62.5/125um OM1 MULTIMODE, PVC	3 METER	ORANGE	BLACK
FPSTD3MM	50/125um OM2 MULTIMODE, PVC	3 METER	WHITE	BLACK
FPSTS3SM	9/125um OS2 SINGLEMODE, PVC	3 METER	YELLOW	BLUE
FPSTE3MM	50/125um OM3 MULTIMODE, PVC	3 METER	AQUA	BLACK
FPSTF3MM	50/125um OM4 MULTIMODE, PVC	3 METER	AQUA	BLACK
FPSTC1MMZ	62.5/125um OM1 MULTIMODE, LSZH	1 METER	ORANGE	BLACK
FPSTD1MMZ	50/125um OM2 MULTIMODE, LSZH	1 METER	WHITE	BLACK
FPSTS1SMZ	9/125um OS2 SINGLEMODE, LSZH	1 METER	YELLOW	BLUE
FPSTE1MMZ	50/125um OM3 MULTIMODE, LSZH	1 METER	AQUA	BLACK
FPSTF1MMZ	50/125um OM4 MULTIMODE, LSZH	1 METER	AQUA	BLACK

NOTES:

- CONNECTOR OPTICAL, MECHANICAL AND ENVIRONMENTAL PERFORMANCE MEETS TIA568-C.3 SPECIFICATIONS.
- CONNECTOR USES A PC (MULTIMODE) OR UPC (SINGLEMODE) RADIUS TIP ZIRCONIA CERAMIC FERRULE.
- CONNECTOR NUT IS NICKEL PLATED ZINC DIE CAST.
- OPTICAL INSERTION LOSS TEST DATA INCLUDED IN EACH BAGGED PIGTAIL.
- 50/125um OM3 MULTIMODE FIBER IS RATED FOR 10Gb/s TRANSMISSION FOR UP TO 300 METERS AT 850nm.
- 50/125um OM4 MULTIMODE FIBER IS RATED FOR 100Gb/s TRANSMISSION FOR UP TO 150 METERS AT 850nm.
- SPECIFICATIONS SUBJECT TO CHANGE WITHOUT NOTICE.

REV.	ECN	DATE	DESCRIPTION	CHG BY	APPD BY
E	18023	10/8/12	ADDED LSZH CATALOG NUMBERS	CG	

Created on AUTOCAD

HUBBELL
Hubbell Premise Wiring
HUBBELL INCORPORATED (Delaware)
14 Lord's Hill Road, Stonington, Connecticut 06378

FIBER PIGTAIL
ASSY, ST SWMM

11914C

SCALE: 1/1 SHEET 1 OF 1

REV. **E**

APPROVED BY: JON LUTZEN 01/29/03

CHECKED BY: JON LUTZEN 01/29/03

DRAWN BY: PAUL S. MAGUIRE 01/27/03

MATERIAL:

PROJECT REFERENCE:

DIMENSIONING AND TOLERANCE PER ANSI Y14.5M-1982 UNLESS OTHERWISE SPECIFIED, DIMENSIONS ARE IN INCHES (MM). TOLERANCES:
.XX = ±.01 (.25)
.XXX = ±.005 (.127)
.XXXX = ±.0025 (.0635)
ANGLE TOL ±1°

IN ACCEPTING OUR DRAWINGS, BLUEPRINTS, OR SUPPORTING DOCUMENTATION FOR QUOTATION OR OTHER PURPOSES, YOU AGREE NOT TO DISCLOSE TO OTHERS THE IDEAS, INFORMATION, OR DESIGNS SHOWN HEREIN, AND THAT YOU WILL MAKE NO USE OF SAME WITHOUT PERMISSION