

6 5 4 3 2 1

CATALOG NUMBER	DESCRIPTION	SPLIT SLEEVE MATERIAL
FSPST6X	UNLOADED 6PK PANEL FOR ST SIMPLEX ADAPTERS	N/A
FSPST6	LOADED 6PK PANEL WITH 6 SM/MM ST SIMPLEX ADAPTERS	PHOSPHOR BRONZE
FSPSTSS6	LOADED 6PK PANEL WITH 6 SM/MM ST SIMPLEX ADAPTERS	ZIRCONIA

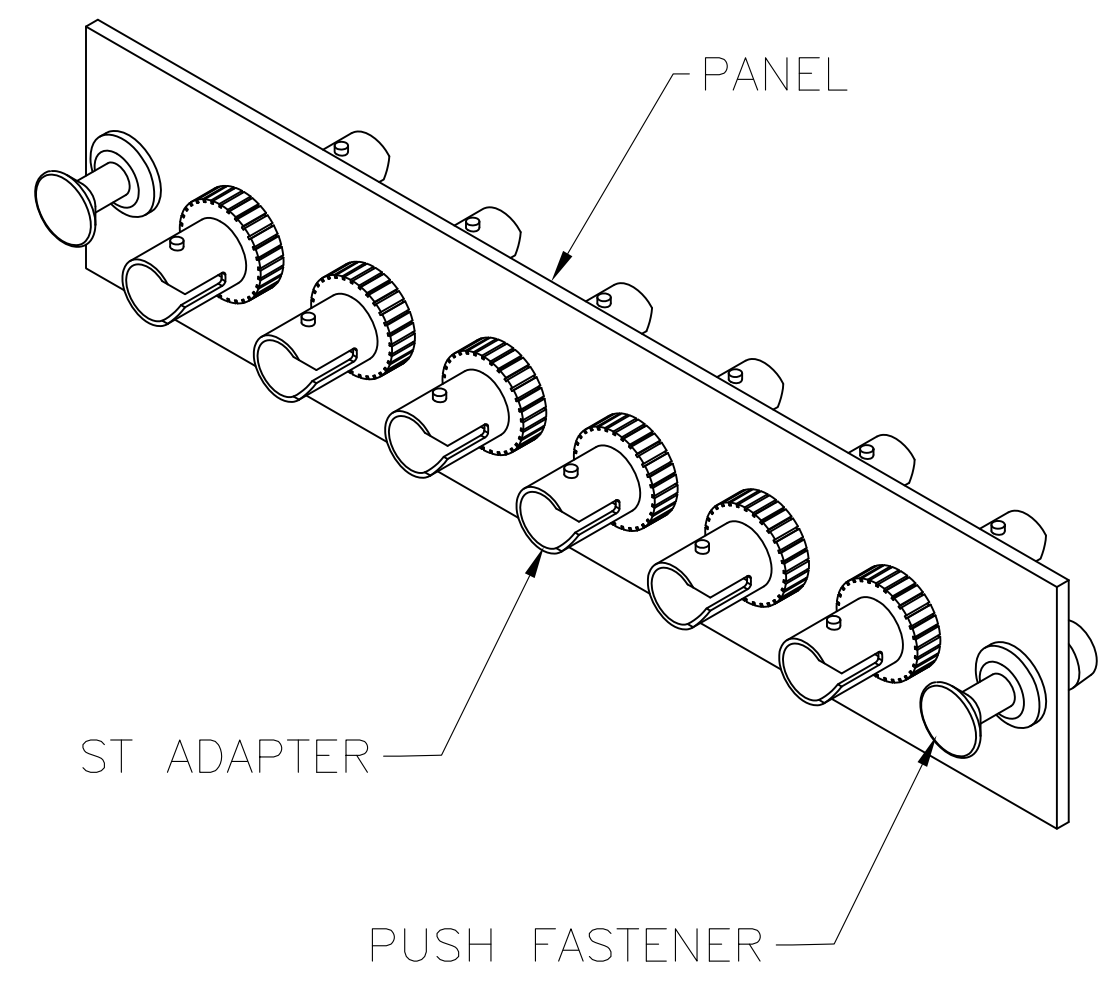
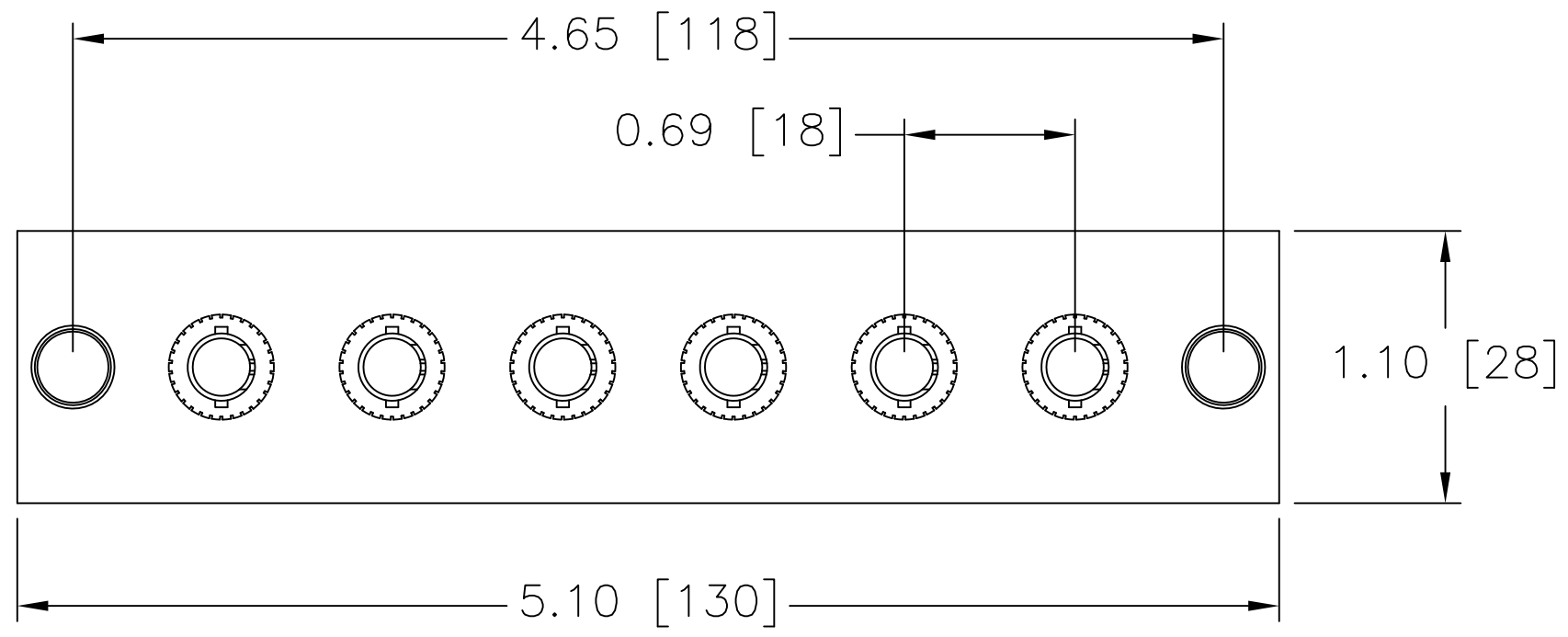
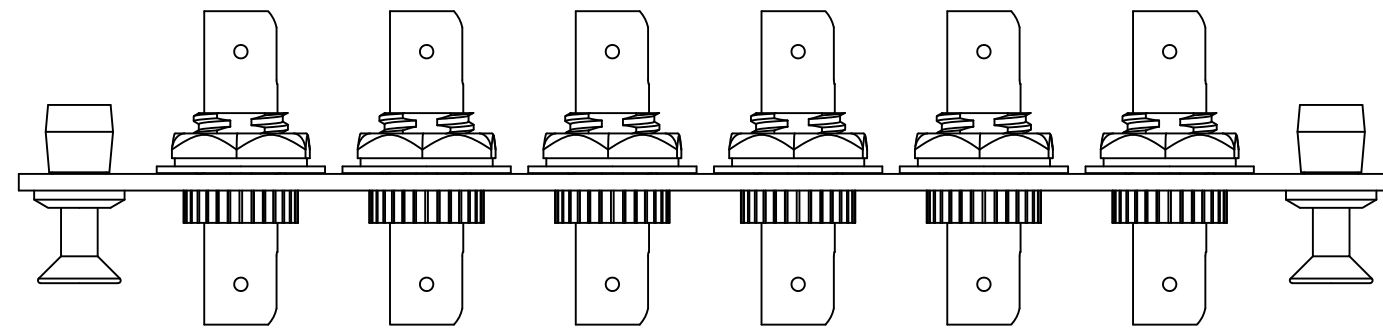
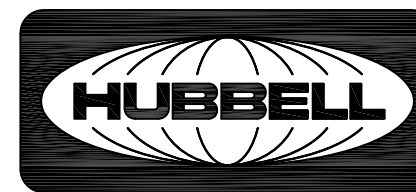

- NOTES:
- SUPPLIED WITH PUSH/PULL FASTENERS FOR EASY INSTALLATION/REMOVAL.
 - PANELS FIT INTO HUBBELL WALL MOUNT AND RACK MOUNT CABINETS.
 - BLACK ELECTROSTATICALLY APPLIED POWDER COAT.
 - SPLIT SLEEVE MATERIAL – SEE TABLE
 - ADAPTERS SUPPLIED WITH DUST CAPS INSTALLED – (NOT SHOWN).
 - SPECIFICATIONS SUBJECT TO CHANGE WITHOUT NOTICE.

Created on AUTOCAD	DIMENSIONING AND TOLERANCE PER ANSI Y14.5M-1982 UNLESS OTHERWISE SPECIFIED, DIMENSIONS ARE IN INCHES (MM). TOLERANCES .XX = ±.01 (.25) .XXX = ±.005 (.127) .XXXX = ±.0025 (.0635) ANGLE TOL ±1°		PROJECT REFERENCE: MATERIAL: .0598" CRS WITH BLACK POWDER COAT FINISH		 Hubbell Premise Wiring HUBBELL INCORPORATED (Delaware) 14 Lord's Hill Road, Stonington, Connecticut 06378
	IN ACCEPTING OUR DRAWINGS, BLUEPRINTS, OR SUPPORTING DOCUMENTATION FOR QUOTATION OR OTHER PURPOSES, YOU AGREE NOT TO DISCLOSE TO OTHERS THE IDEAS, INFORMATION, OR DESIGNS SHOWN HEREIN, AND THAT YOU WILL MAKE NO USE OF SAME WITHOUT PERMISSION		DRAWN BY: PAUL S. MAGUIRE 010CT01		
TITLE: SIX PACK PANEL WITH ST ADAPTERS		SIZE: B	DRAWING NO.: 11575C	REV.: D	
SCALE: 1/1		SHEET 1 OF 1			

REV.	ECN	DATE	DESCRIPTION	CHG BY	APPD BY
D	22457	6/22/17	ADDED FSPST6X	AK	MMA