

CATALOG NO.	DESCRIPTION
FTUOS2SP	FIBER, WALLMNT CAB, OSP-4X, 2 FSP PNL

- NOTES:
1. MATERIAL: 11 Ga ALUMINUM
SURFACE FINISH: TAN POWDER COAT
 2. ACCEPTS UP TO (2) STANDARD FSP PANELS
ACCOMODATES UP TO (3) 7" SPLICE TRAYS
 3. SPECIFICATION SUBJECT TO CHANGE WITHOUT NOTICE.

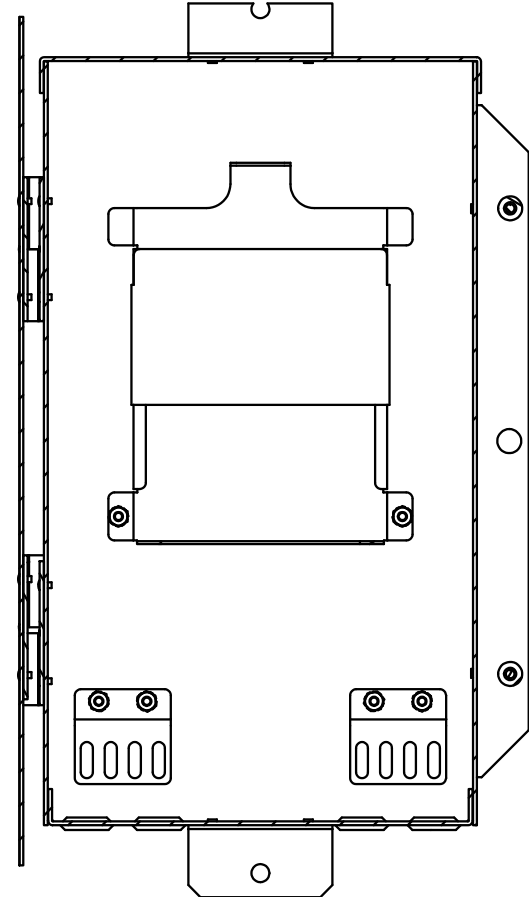

SECTION J-J
SCALE 1 / 4

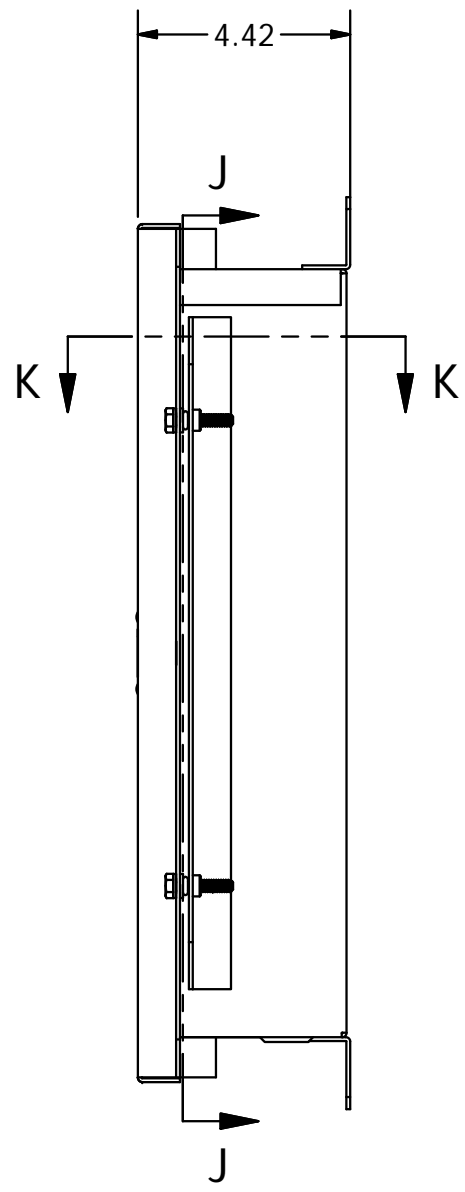
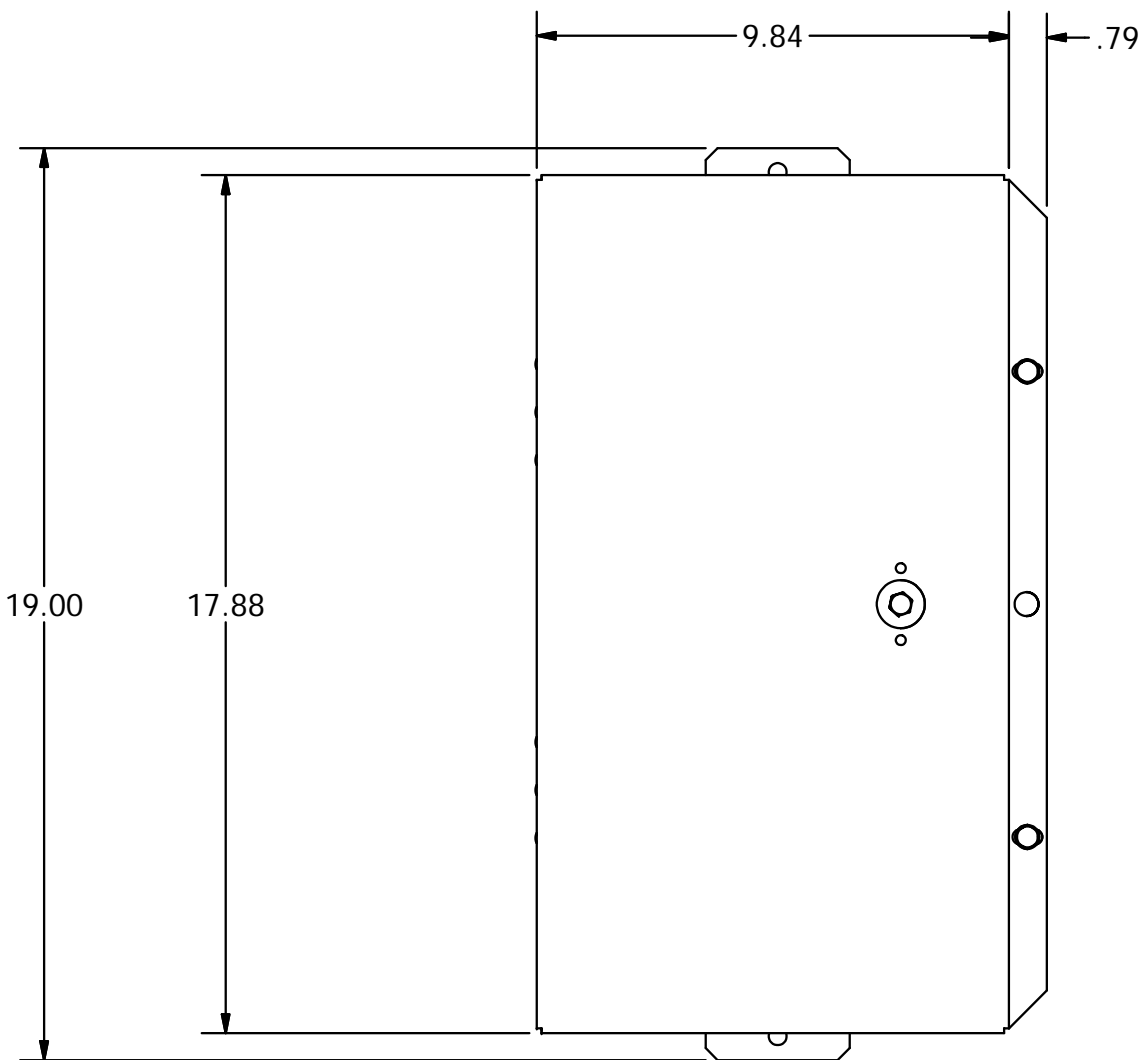
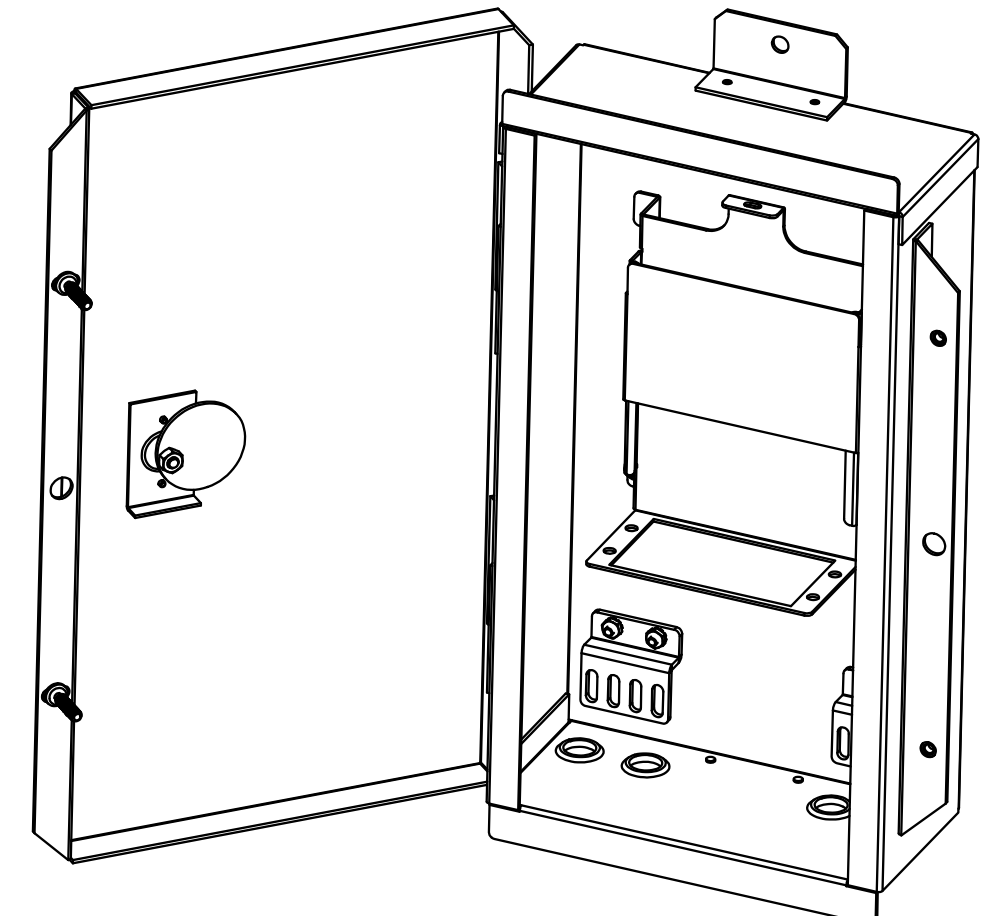
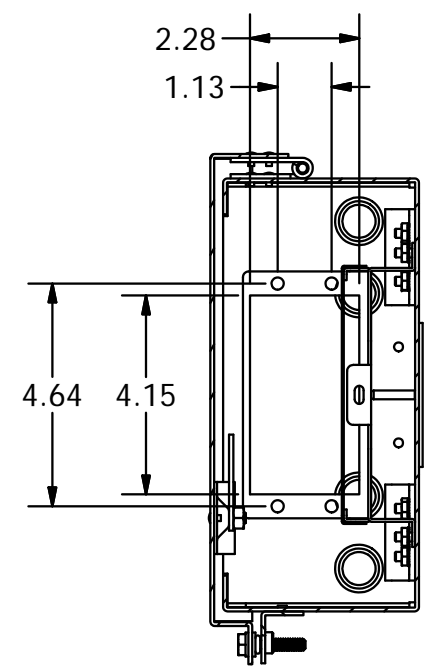

SECTION K-K
SCALE 1 / 4

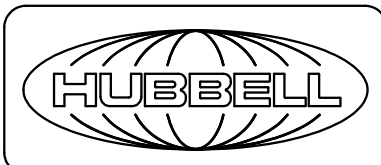
Created on INVENTOR	DIMENSIONING AND TOLERANCE PER ANSI Y14.5M-1982 UNLESS OTHERWISE SPECIFIED, DIMENSIONS ARE IN INCHES (MM). TOLERANCES: XX = ±.01 (.25) .XXX = ±.005 (.127) .XXXX = ±.0025 (.0635) ANGLE TOL ±1°		PROJECT REFERENCE: NPD 00160		 Hubbell Premise Wiring HUBBELL INCORPORATED (Delaware) 23 CLARA DRIVE, SUITE 103 MYSTIC, CT 06355		
	IN ACCEPTING OUR DRAWINGS, BLUEPRINTS, OR SUPPORTING DOCUMENTATION FOR QUOTATION OR OTHER PURPOSES, YOU AGREE NOT TO DISCLOSE TO OTHERS THE IDEAS, INFORMATION, OR DESIGNS SHOWN HEREIN, AND THAT YOU WILL MAKE NO USE OF SAME WITHOUT PERMISSION		DRAWN BY: MABBY 09/27/16			TITLE: FIBER WALL MOUNT CABINET, OSP-4X, 2 FSP PANEL OPENINGS	
			CHECKED BY:		SIZE: C	DRAWING NO.: HWS14703C	REV.: 1
			APPROVED BY:		SCALE: N/A	SHEET 1 OF 1	

1	21498	10/28/16	INITIAL RELEASE	MMA	DO
REV.	ECN	DATE	DESCRIPTION	CHG BY	APPD BY