

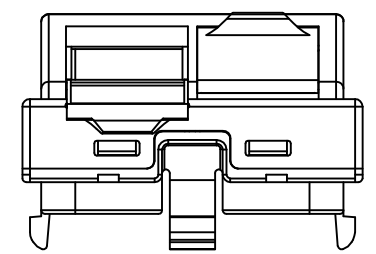

HFM2A2

2 PORT ANGLED SHUTTERED FRENCH MODULE, WHITE

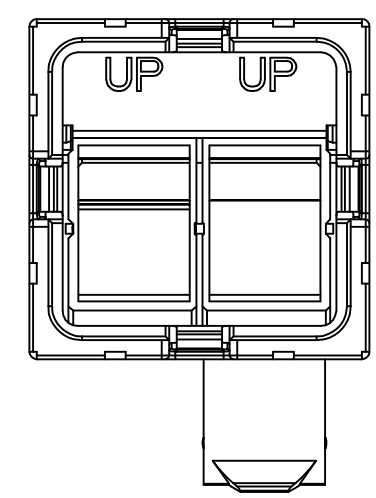
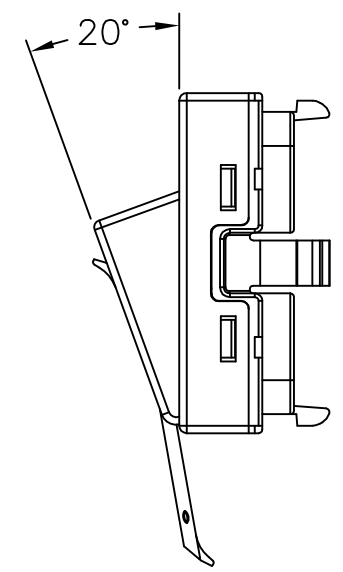
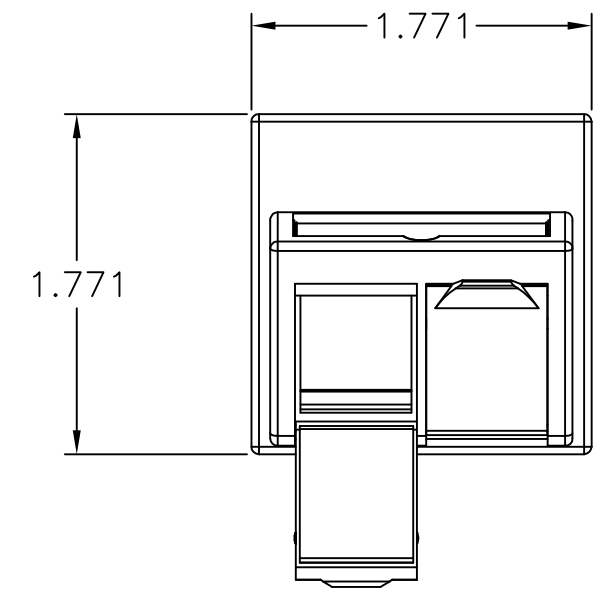
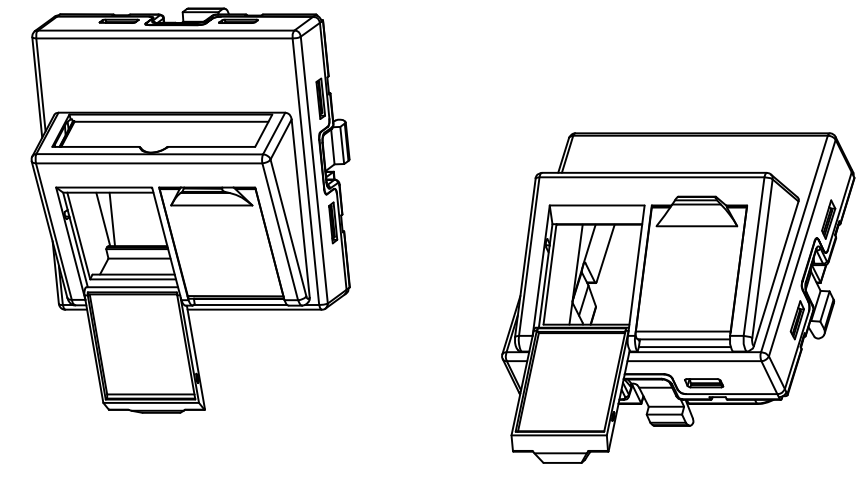
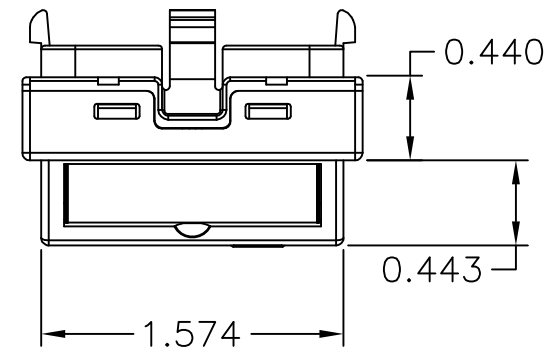

NOTES:

- 1. MATERIAL: ABS THERMOPLASTIC, WHITE
- 2. ACCEPTS HUBBELL XJ AND HJ JACKS.
- 3. SPECIFICATIONS SUBJECT TO CHANGE WITHOUT NOTICE.

Created on AUTOCAD	DIMENSIONING AND TOLERANCE PER ANSI Y14.5M-1982 UNLESS OTHERWISE SPECIFIED, DIMENSIONS ARE IN INCHES (MM). TOLERANCES .XX = ±.01 (.25) .XXX = ±.005 (.127) .XXXX = ±.0025 (.0635) ANGLE TOL ±1°		PROJECT REFERENCE: NPD-00208		 Hubbell Premise Wiring HUBBELL INCORPORATED (Delaware) 23 CLARA DRIVE, SUITE 103 MYSTIC, CT 06355	
	IN ACCEPTING OUR DRAWINGS, BLUEPRINTS, OR SUPPORTING DOCUMENTATION FOR QUOTATION OR OTHER PURPOSES, YOU AGREE NOT TO DISCLOSE TO OTHERS THE IDEAS, INFORMATION, OR DESIGNS SHOWN HEREIN, AND THAT YOU WILL MAKE NO USE OF SAME WITHOUT PERMISSION		MATERIAL: SEE NOTE 1			TITLE: 2 PORT, ANGLED, SHUTTERED, FRENCH MODULE
			DRAWN BY: D.O'CONNOR 7/14/16		SIZE: B	REV. 1
			CHECKED BY:		DRAWING NO. HWS14599C	
		APPROVED BY:		SCALE: NTS	SHEET 1 OF 1	

1	21475	7/14/15	INITIAL RELEASE	DPO	MMA
REV.	ECN	DATE	DESCRIPTION	CHG BY	APPD BY