

ITEM NO.	DESCRIPTION	QTY.
1	COMPRESSION LUG (1 OR 2)	1/2
2	#6 AWG THHN GREEN GROUND WIRE	--
3	GROUND WIRE WARNING LABEL	2
4	ADHESIVE GROUND WIRE I.D. LABEL	1
5	1/2 OZ. TUBE OF PENETROX-A	1
6	INSTRUCTION SHEET	1

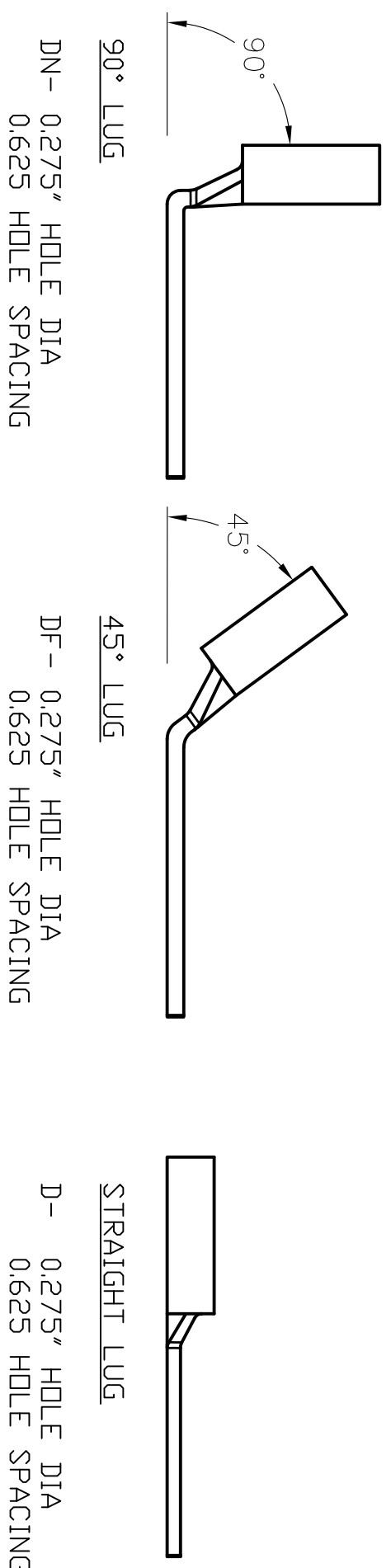

- DN - 0.275" HOLE DIA  
0.625 HOLE SPACING
- DF - 0.275" HOLE DIA  
0.625 HOLE SPACING
- DA - 0.275" HOLE DIA  
0.750" HOLE SPACING
- DB - 0.375" HOLE DIA  
1.00" HOLE SPACING
- S - .275" DIA SINGLE HOLE

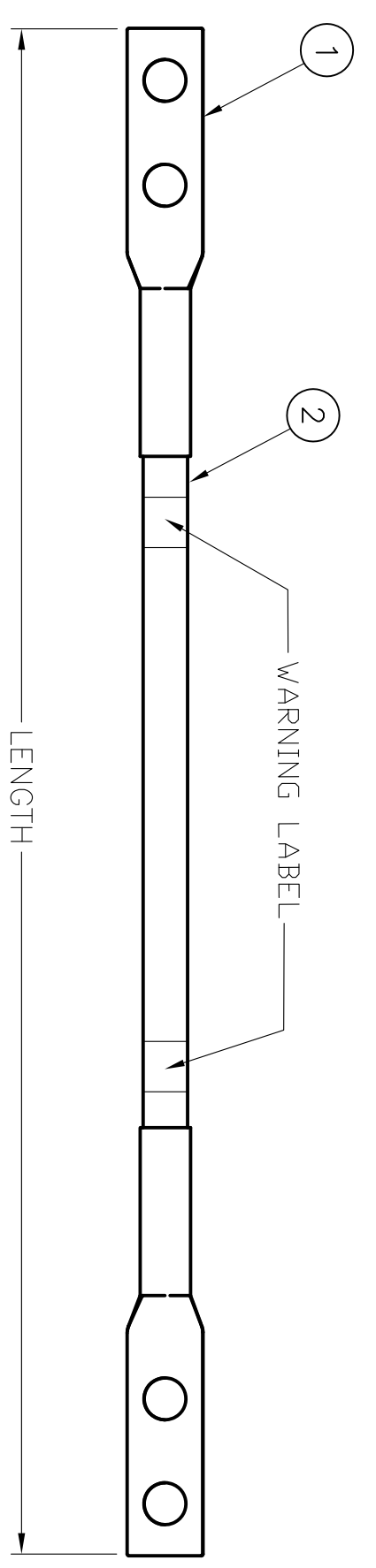

**IF THIS CONNECTOR OR CABLE IS LOOSE OR MUST BE REMOVED, PLEASE CALL THE BUILDING TELECOMMUNICATIONS MANAGER**

WARNING LABEL INSTALLED ON BOTH ENDS OF THE GROUNDING JUMPER TO PROTECT THE GROUNDING AND BONDING NETWORK. DO NOT REMOVE!!

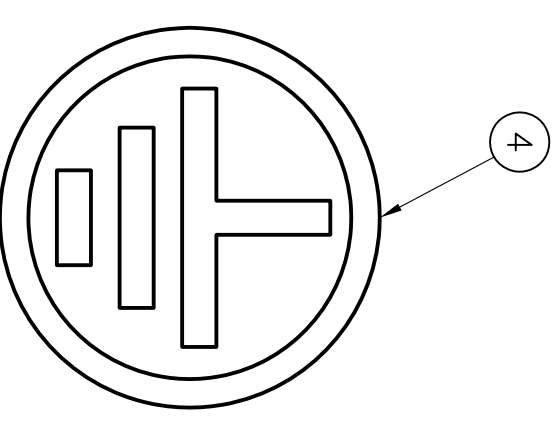

CONFIGURE THE PART NUMBER AS FOLLOWS:  
 BASE \_\_\_\_\_ LUG1 \_\_\_\_\_ LENGTH(INCHES) \_\_\_\_\_ LUG2 \_\_\_\_\_  
 HGRT + D + ANY LENGTH + D  
 DA DA IN INCHES DF  
 DB DN  
 X DA  
 S DB  
 S

WHEN CONFIGURING GROUND JUMPER KITS, IF ONLY ONE 'D' LUG IS USED, IT MUST BE ENTERED IN THE LUG 1 POSITION.  
 IF A 'DA' AND 'DB' CONFIGURATION IS USED, 'DA' MUST BE ENTERED IN THE LUG 1 POSITION.  
 'X' IS USED WHEN ONE END OF THE JUMPER DOES NOT REQUIRE A LUG.

**NOTES**  
 1. SPECIFICATIONS SUBJECT TO CHANGE WITHOUT NOTICE

REV.	ECN	DATE	DESCRIPTION	CHG BY	APPD BY
2	18115	04/24/13	ADDED "S" OPTION	MMA	

Created on AUTOCAD

DIMENSIONING AND TOLERANCE PER ANSI Y14.5M-1982 UNLESS OTHERWISE SPECIFIED, DIMENSIONS ARE IN INCHES (MM). TOLERANCES: .XX = ±.01 (.25) .XXX = ±.005 (.127) .XXXX = ±.0025 (.0635) ANGLE TOL .±1°		PROJECT REFERENCE: <b>2011-041</b>
IN ACCEPTING OUR DRAWINGS, BLUEPRINTS, OR SUPPORTING DOCUMENTATION FOR QUOTATION OR OTHER PURPOSES, YOU AGREE NOT TO DISCLOSE TO OTHERS THE IDEAS, INFORMATION, OR DESIGNS SHOWN HEREIN, AND THAT YOU WILL MAKE NO USE OF SAME WITHOUT PERMISSION.		DRAWN BY: C. GRIBBLE 7/16/12
CHECKED BY:		APPROVED BY:

HUBBELL Hubbell Premise Wiring HUBBELL INCORPORATED (Delaware) 14 Lord's Hill Road, Stonington, Connecticut 06378	TITLE: GROUNDING JUMPER KITS	SIZE: C DRAWING NO.: HWS13026C SCALE: NTS	SHEET 1 OF 1	REV. 2
--	---------------------------------	---	--------------	--------