

CATALOG NO.	SURFACE FINISH
HLCB	BLACK
HLCG	GRAY

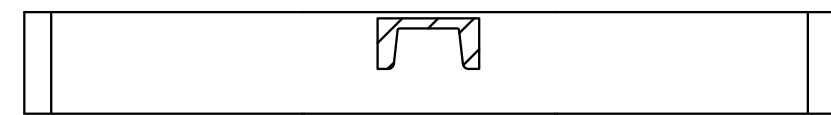

SECTION B-B

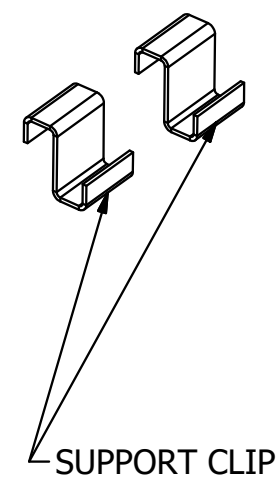
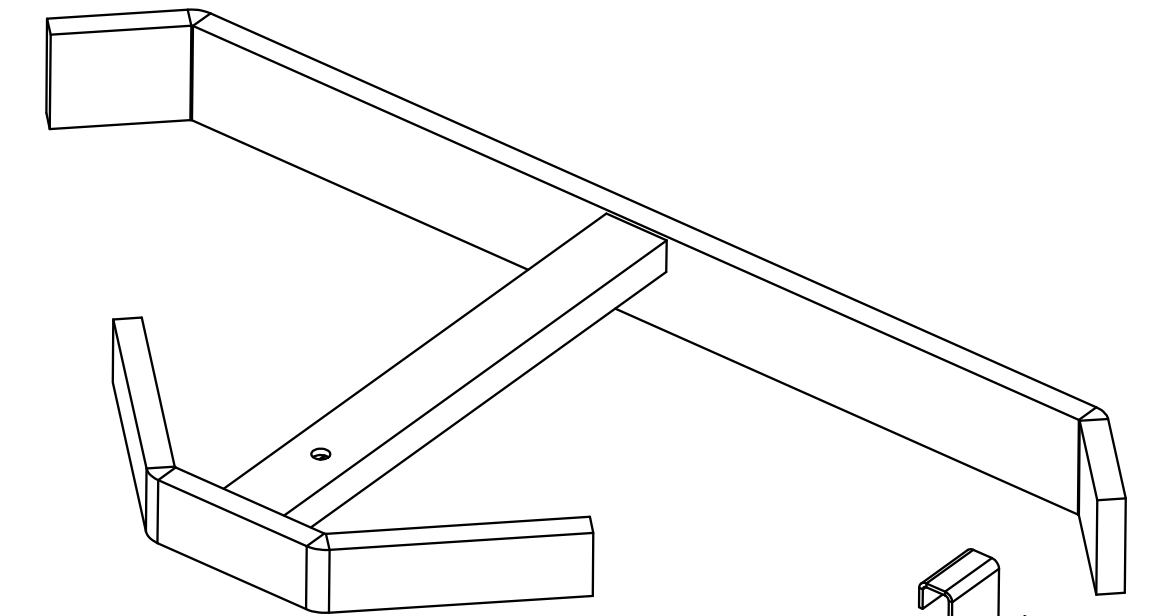
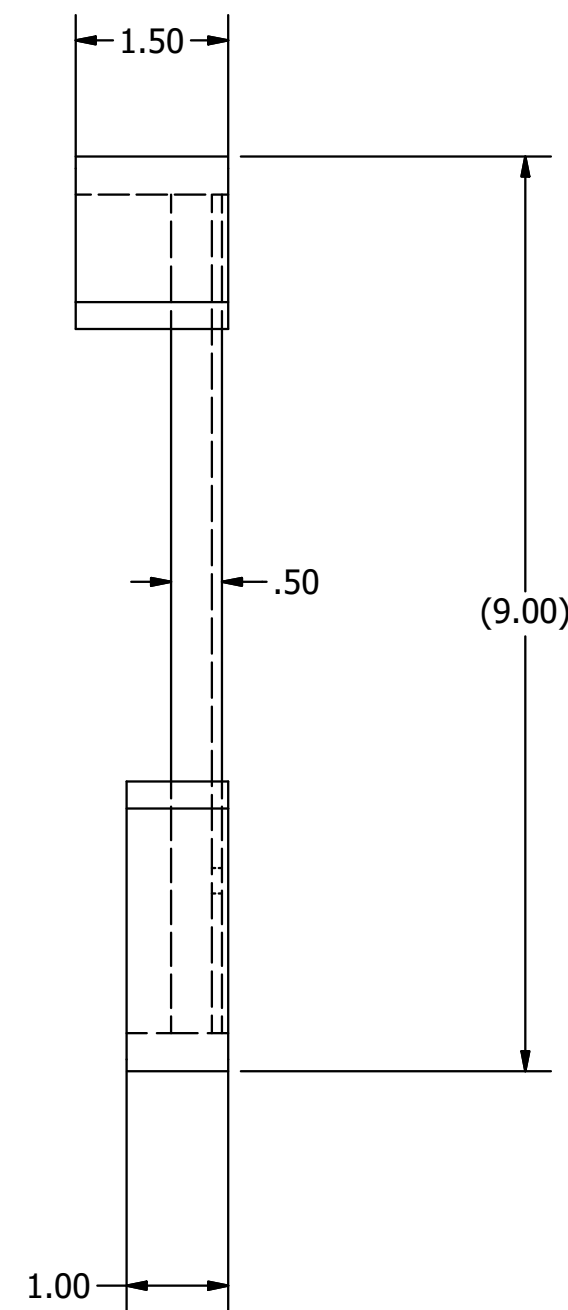
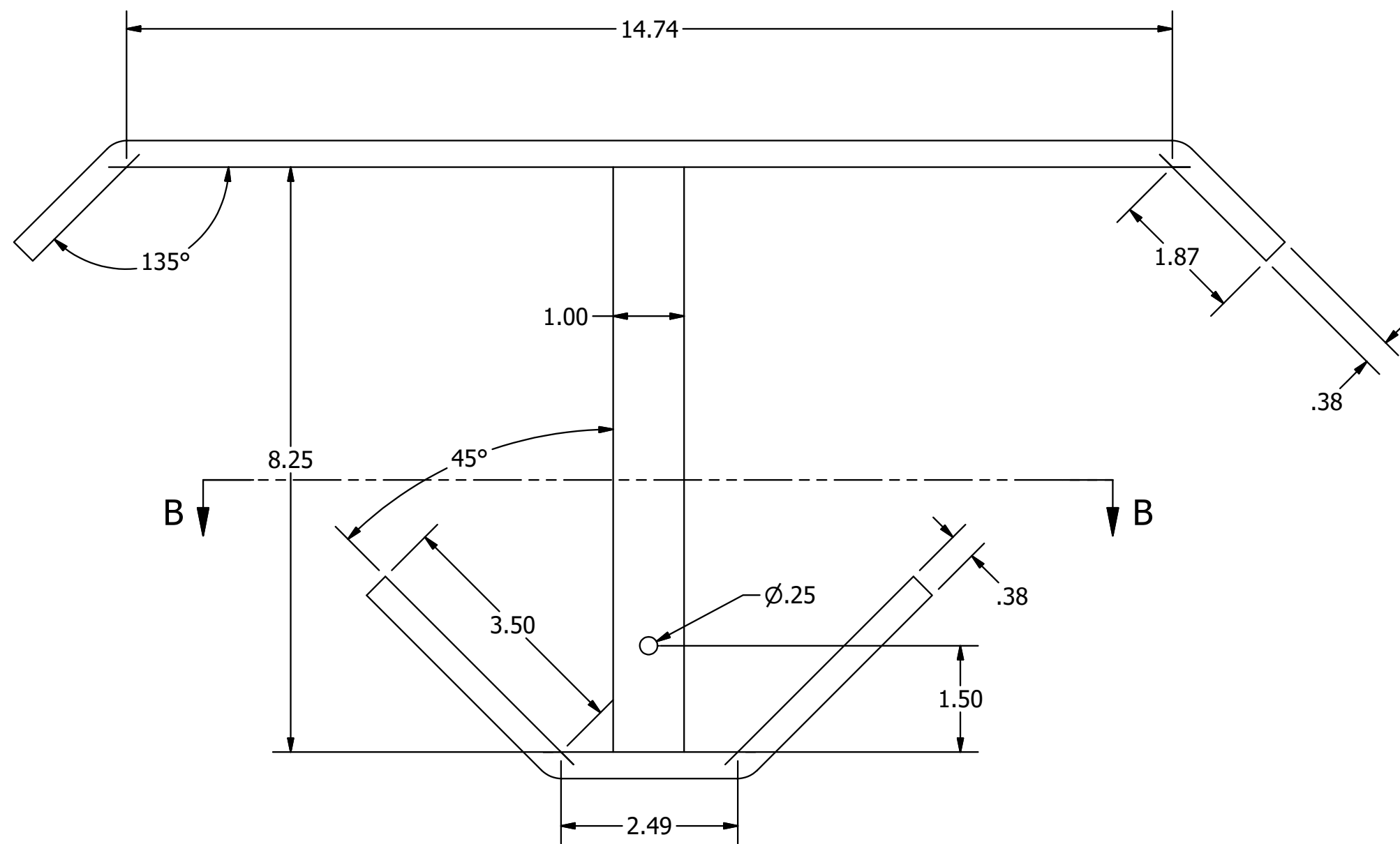

SUPPORT CLIP

NOTES:

- KIT CONTAINS:
 (1) CORNER BRACKET
 (2) SUPPORT CLIPS
- SURFACE FINISH: POWDER COAT, SEE TABULATION FOR COLOR
- SPECIFICATIONS SUBJECT TO CHANGE WITHOUT NOTICE.

Created on INVENTOR

DIMENSIONING AND TOLERANCE PER ANSI Y14.5M-1982 UNLESS OTHERWISE SPECIFIED, DIMENSIONS ARE IN INCHES (MM). TOLERANCES: XX = ±.01 (.25) .XXX = ±.005 (.127) .XXXX = ±.0025 (.0635) ANGLE TOL ±1°

IN ACCEPTING OUR DRAWINGS, BLUEPRINTS, OR SUPPORTING DOCUMENTATION FOR QUOTATION OR OTHER PURPOSES, YOU AGREE NOT TO DISCLOSE TO OTHERS THE IDEAS, INFORMATION, OR DESIGNS SHOWN HEREIN, AND THAT YOU WILL MAKE NO USE OF SAME WITHOUT PERMISSION

PROJECT REFERENCE:
044-17

MATERIAL:
STEEL

DRAWN BY:
MABBY 11/16/17

CHECKED BY:

APPROVED BY:

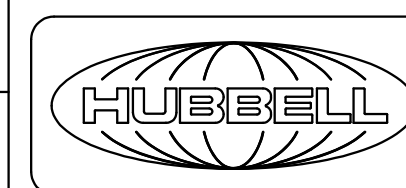

Hubbell Premise Wiring
 HUBBELL INCORPORATED (Delaware)
 14 Lord's Hill Road, Stonington, Connecticut 06378

TITLE:
LADDER CORNER SUPPORT BRACKET

SIZE: C DRAWING NO.: HWS14780C REV.: 1

SCALE: N/A SHEET 1 OF 1

1	22526	11/22/17	INITIAL RELEASE	MMA	DO
REV	ECN	DATE	DESCRIPTION	CHG BY	APPD BY