

CATALOG	DESCRIPTION	BRACKET HEIGHT "H"	LADDER HEIGHT "L"
HLEK23	2-3" LADDER ELEVATION KIT	5.38	4.0; 5.0; 6.0
HLEK46	4-6" LADDER ELEVATION KIT	8.50	2.0; 2.5; 3.0

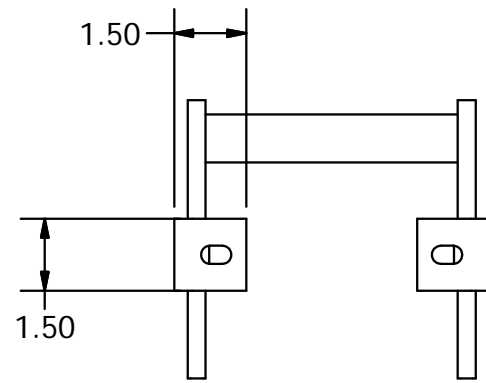

SHOWN ASSEMBLE TO LADDER RACK
(LADDER RACK SOLD SEPARATELY)

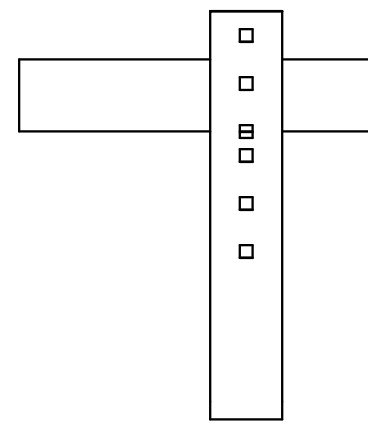
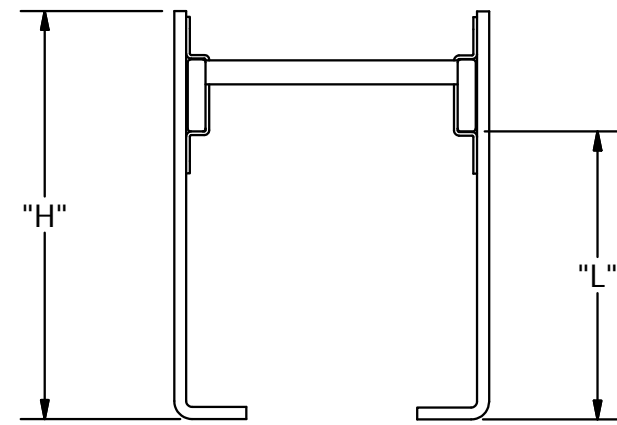
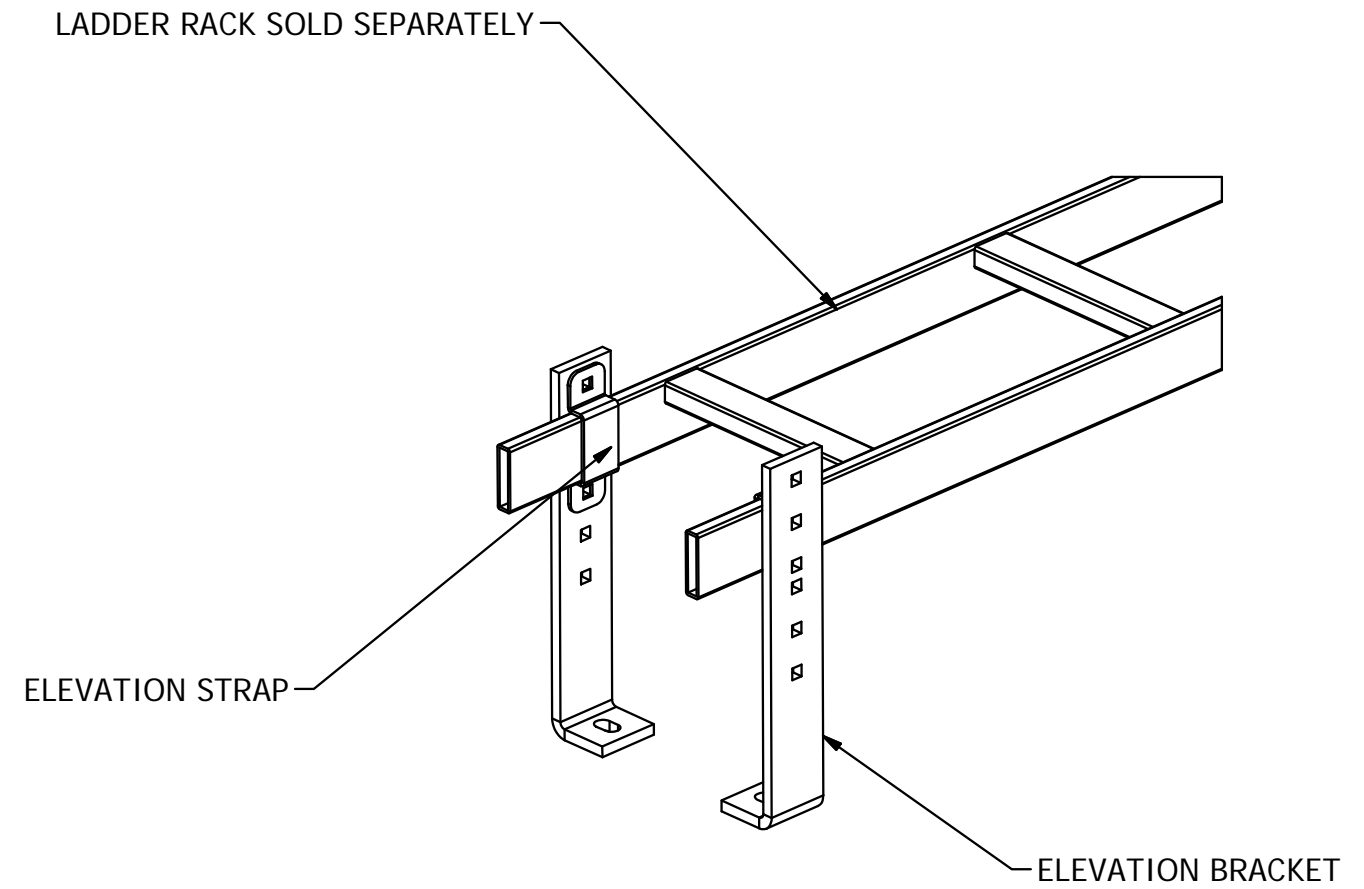

NOTES:

1. SURFACE FINISH: BLACK POWDER COAT
2. KIT CONTAINS:
 - (2) ELEVATION BRACKETS
 - (2) ELEVATION STRAPS
 - (4) 1/4-20 X 3/4 CARRIAGE BOLT
 - (4) 1/4" SPLIT LOCK WASHER
 - (4) 1/4"-20 HEX NUT
 - (2) 3/8"-16 x 1" HEX CAP BOLT
 - (2) 3/8"-16 HEX NUT
 - (2) 3/8" FLAT WASHER
 - (2) 3/8" LOCK WASHER
3. SPECIFICATION SUBJECT TO CHANGE WITHOUT NOTICE.

REV.	ECN	DATE	DESCRIPTION	CHG BY	APPD BY
2	19374	01/20/14	CORRECTED DESCRIPTION IN TABLE	MMA	
1	19370	10/30/13	INITIAL RELEASE	MMA	

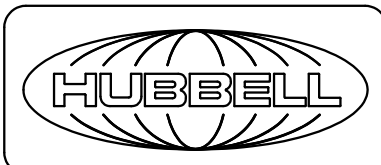
Created on INVENTOR	DIMENSIONING AND TOLERANCE PER ANSI Y14.5M-1982 UNLESS OTHERWISE SPECIFIED, DIMENSIONS ARE IN INCHES (MM). TOLERANCES: XX = ±.01 (.25) .XXX = ±.005 (.127) .XXXX = ±.0025 (.0635) ANGLE TOL ±1°		PROJECT REFERENCE: 080-13		 Hubbell Premise Wiring HUBBELL INCORPORATED (Delaware) 23 CLARA DRIVE, SUITE 103 MYSTIC, CT 06355		
	IN ACCEPTING OUR DRAWINGS, BLUEPRINTS, OR SUPPORTING DOCUMENTATION FOR QUOTATION OR OTHER PURPOSES, YOU AGREE NOT TO DISCLOSE TO OTHERS THE IDEAS, INFORMATION, OR DESIGNS SHOWN HEREIN, AND THAT YOU WILL MAKE NO USE OF SAME WITHOUT PERMISSION		MATERIAL: STEEL			TITLE: LADDER ELEVATION KIT	
			DRAWN BY: MABBY 10/28/13		SIZE C	DRAWING NO. HWS14374C	REV. 2
			CHECKED BY:		SCALE:		SHEET 1 OF 1
		APPROVED BY:					