

CATALOG NO.	DESCRIPTION	SURFACE FINISH
HLH14B	LADDER TRAY STANDOFF,14IN,BK	BLACK
HLH14G	LADDER TRAY STANDOFF,14IN,GY	GRAY
HLH14W	LADDER TRAY STANDOFF,14IN,WHT	WHITE

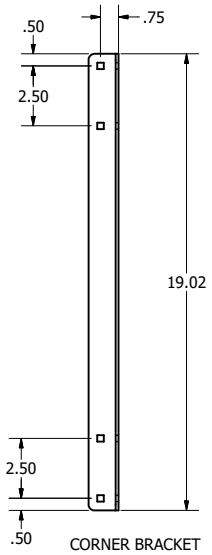

CORNER BRACKET

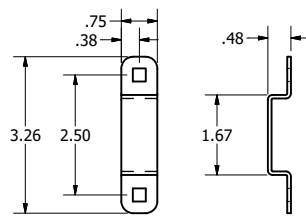
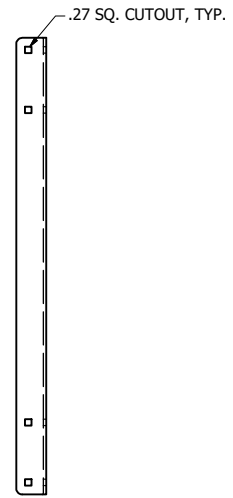

SUPPORT CLIP

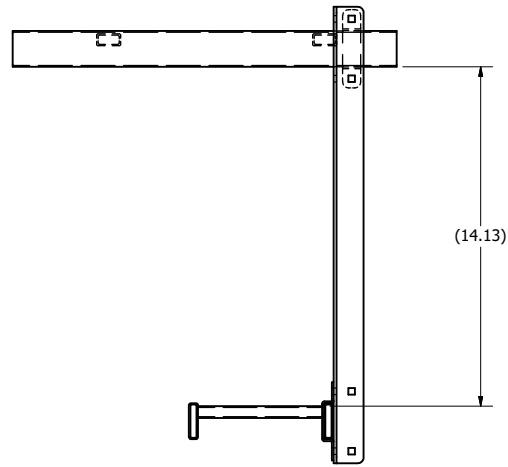
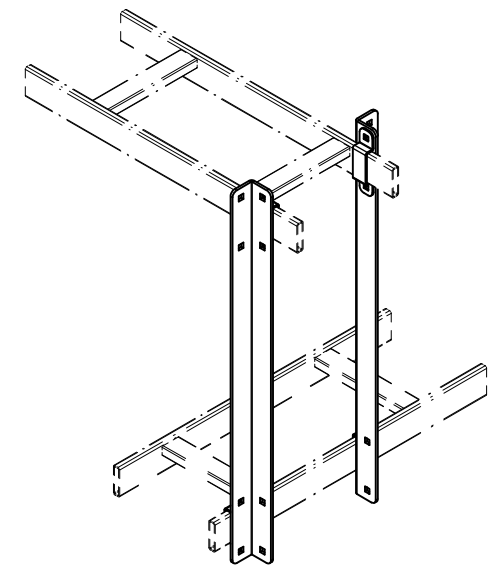

NOTES:

- KIT CONTAINS:
  - (1) CORNER BRACKET
  - (2) SUPPORT CLIPS
  - (8) 1/4-20 X 3/4 CARRAIGE BOLT, BLACK ZINC
  - (8) 1/4 SPLIT LOCK WASHER, BLACK ZINC
  - (8) 1/4-20 HEX NUT, BLACK ZINC
- SURFACE FINISH: POWDER COAT, SEE TABULATION FOR COLOR
- SPECIFICATIONS SUBJECT TO CHANGE WITHOUT NOTICE.

1	22575	03/23/18	INITIAL RELEASE	MMA	DO
REV.	ECN	DATE	DESCRIPTION	CHG BY	APPD BY

Created on INVENTOR

DIMENSIONING AND TOLERANCE PER ANSI Y14.5M-1982 UNLESS OTHERWISE SPECIFIED, DIMENSIONS ARE IN INCHES (MM). TOLERANCES: .XX = ±.01 (.25) .XXX = ±.005 (.127) .XXXX = ±.0025 (.0635) ANGLE TOL ±1°

IN ACCEPTING OUR DRAWINGS, BLUEPRINTS, OR SUPPORTING DOCUMENTATION FOR QUOTATION OR OTHER PURPOSES, YOU AGREE NOT TO DISCLOSE TO OTHERS THE IDEAS, INFORMATION, OR DESIGNS SHOWN HEREIN, AND THAT YOU WILL MAKE NO USE OF SAME WITHOUT PERMISSION

PROJECT REFERENCE: 011-18
MATERIAL: COLD ROLLED STEEL
DRAWN BY: MABBY 03/20/18
CHECKED BY:
APPROVED BY:



**Hubbell Premise Wiring**  
HUBBELL INCORPORATED (Delaware)  
14 Lord's Hill Road, Stonington, Connecticut 06378

TITLE: LADDER CORNER SUPPORT BRACKET		
SIZE C	DRAWING NO. HWS14793C	REV. 1
SCALE: N/A	SHEET 1 OF 1	