

CATALOG	DESCRIPTION
HP5E12	NEXTSPEED C5E, 12 PORT PANEL, BLACK
HP612	NEXTSPEED C6, 12 PORT PANEL, BLACK
HP6A12	NEXTSPEED C6A, 12 PORT PANEL, BLACK

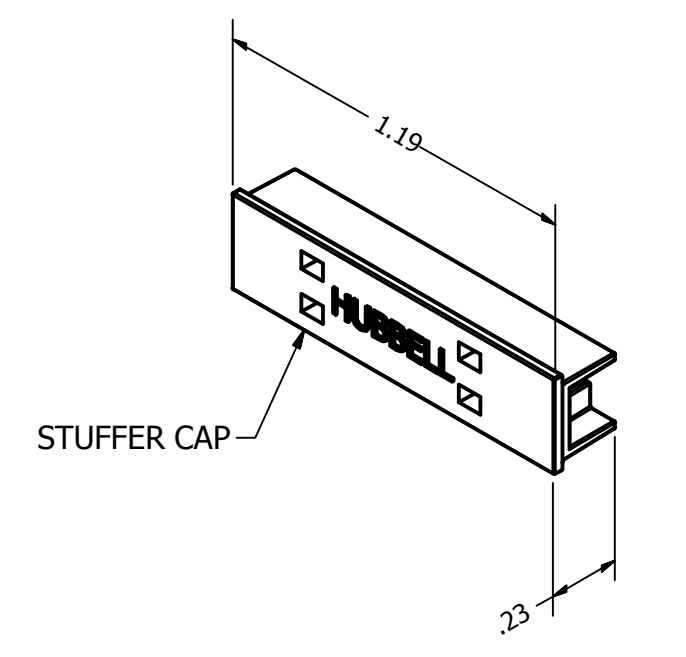

- NOTES:
- PRODUCT CONTAINS:  
 (1) 12 PORT PANEL ASSEMBLY  
 (1) 89D MOUNTING BRACKET  
 (2) LABEL CARDS  
 (2) CLEAR LABEL COVERS  
 (12) STUFFER CAPS
  - SPECIFICATIONS SUBJECT TO CHANGE WITHOUT NOTICE

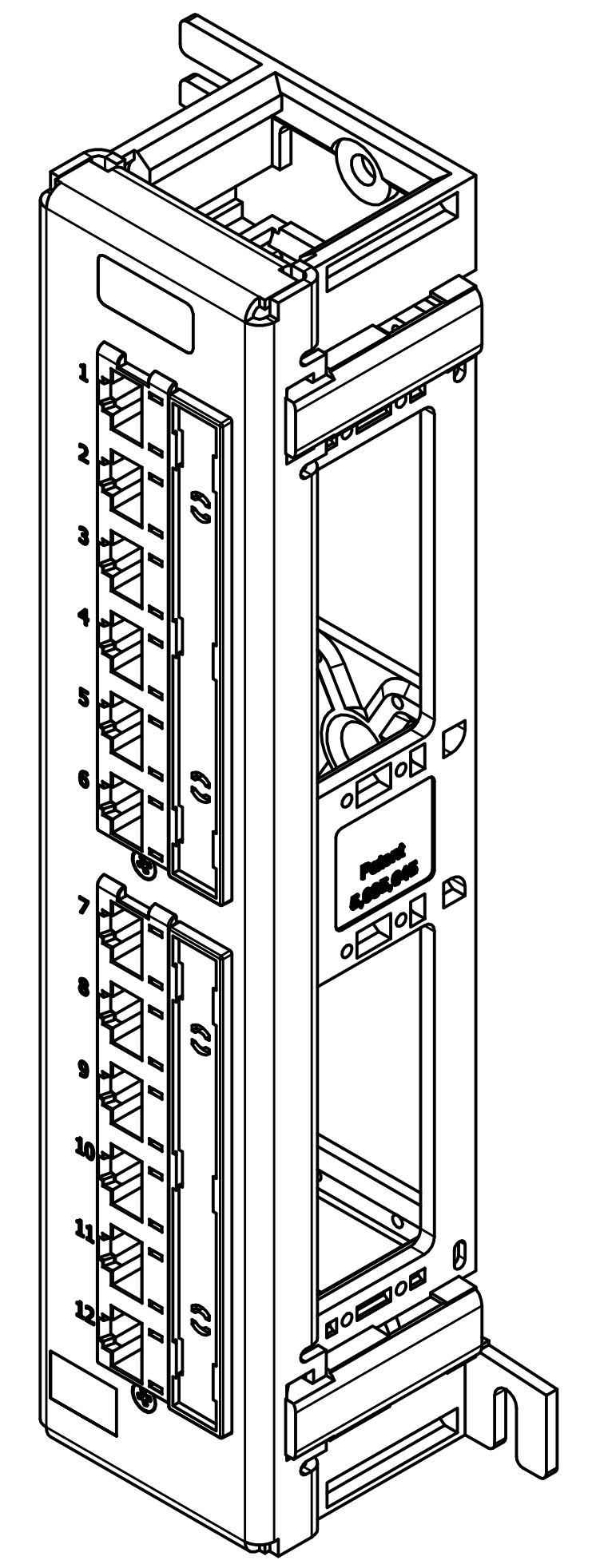
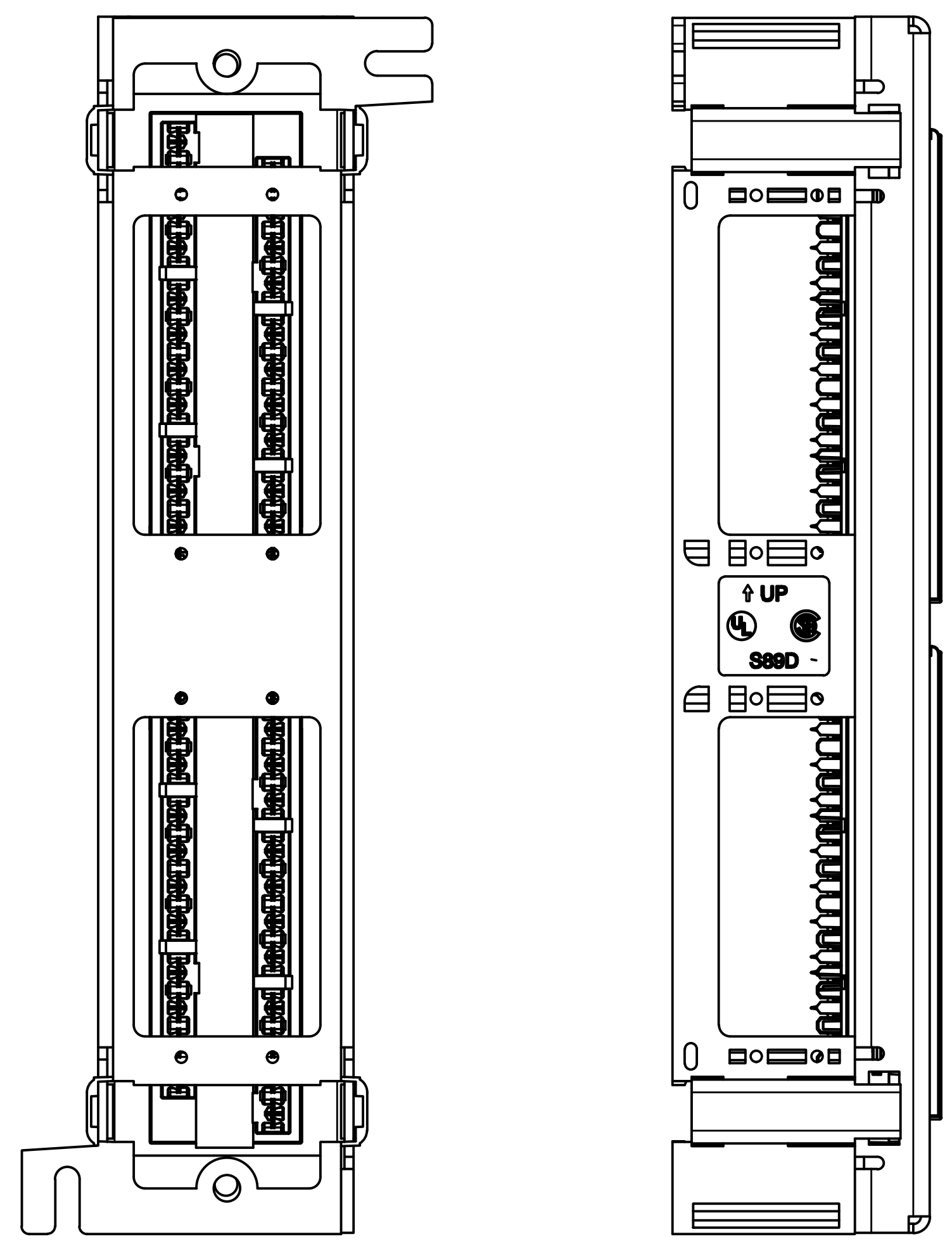
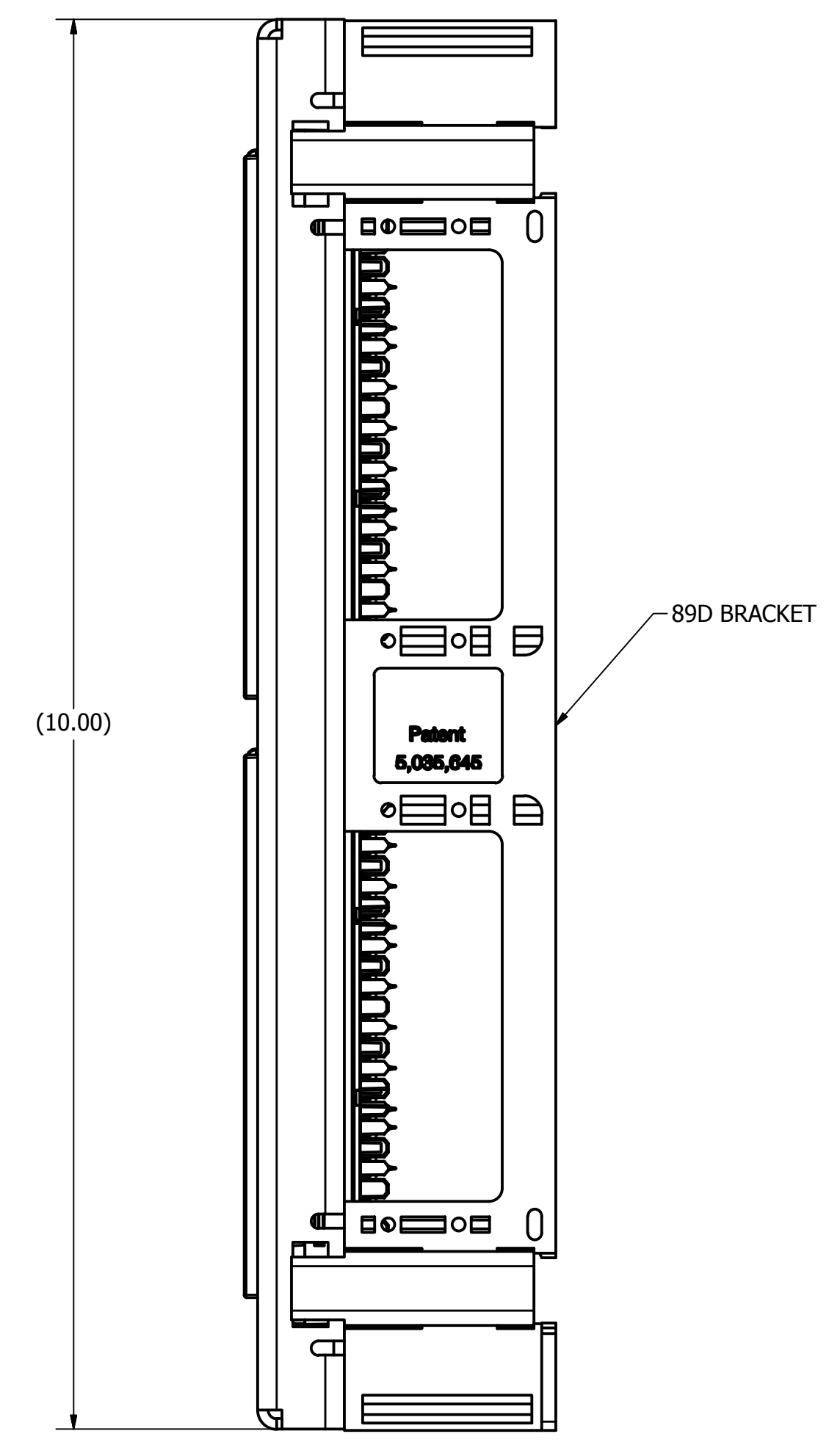
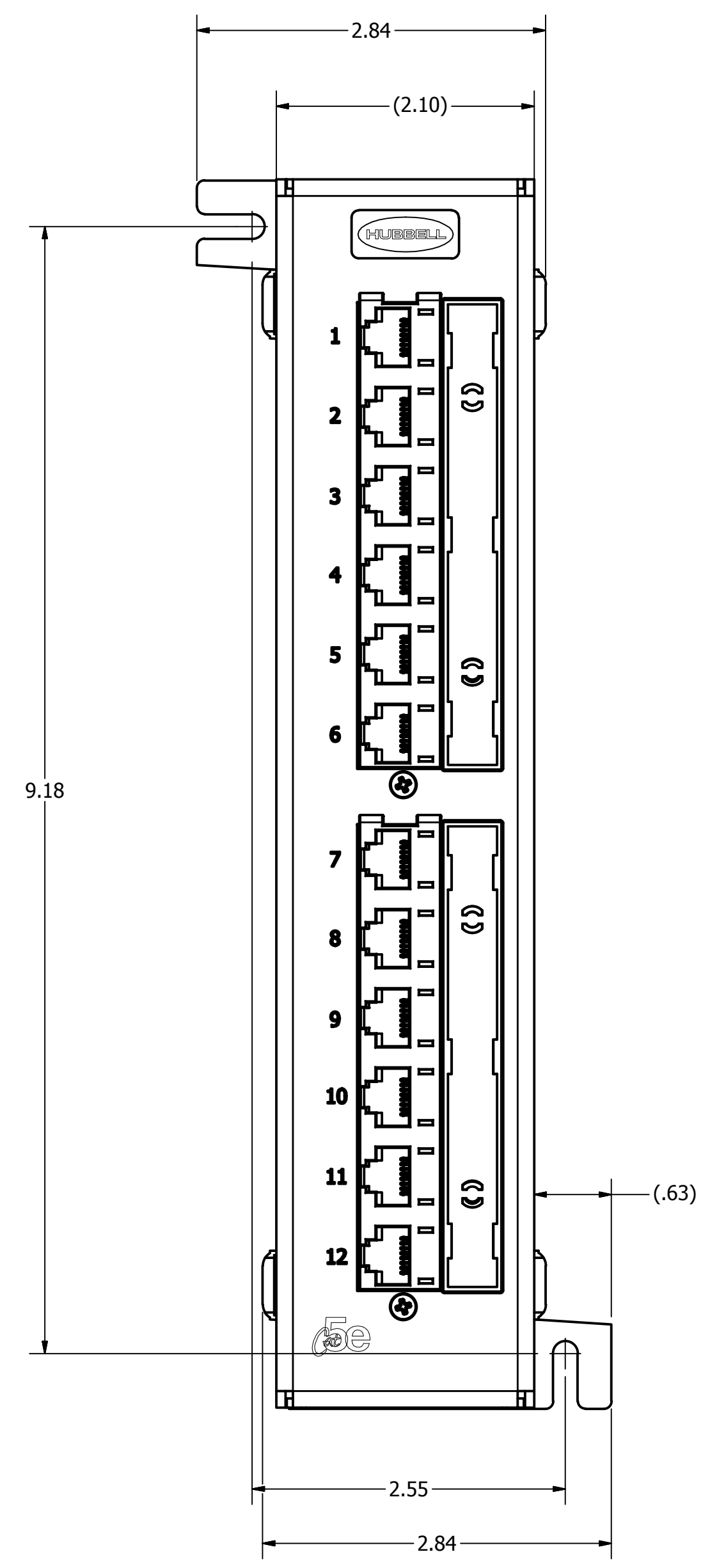
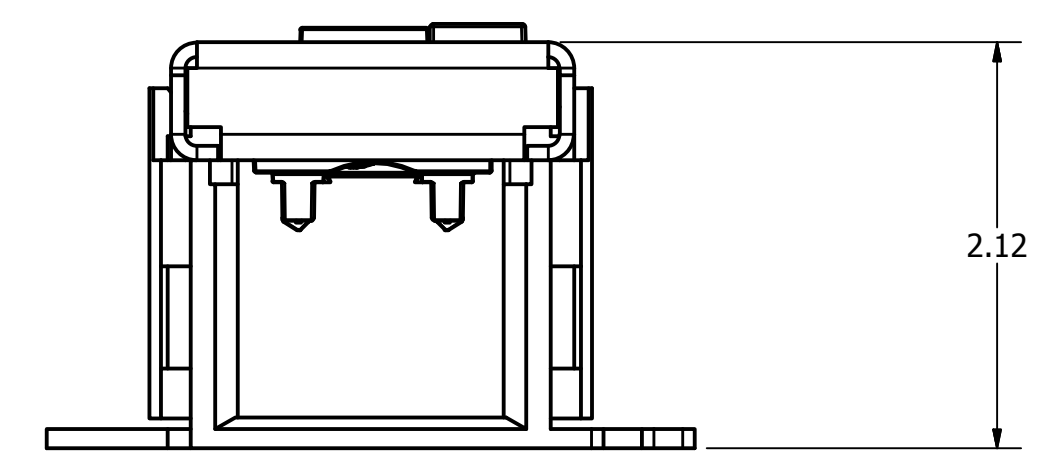

REV.	ECN	DATE	DESCRIPTION	CHG BY	APPD BY
1	17850	2/11/14	INITIAL RELEASE	DPO	

Created on INVENTOR	DIMENSIONING AND TOLERANCE PER ANSI Y14.5M-1982, UNLESS OTHERWISE SPECIFIED, DIMENSIONS ARE IN INCHES (MM). TOLERANCES: XX = ±.01 (.25) .XXX = ±.005 (.127) .XXXX = ±.0025 (.0635) ANGLE TOL ±1°		PROJECT REFERENCE: 2013-017
	IN ACCEPTING OUR DRAWINGS, BLUEPRINTS, OR SUPPORTING DOCUMENTATION FOR QUOTATION OR OTHER PURPOSES, YOU AGREE NOT TO DISCLOSE TO OTHERS THE IDEAS, INFORMATION, OR DESIGNS SHOWN HEREIN, AND THAT YOU WILL MAKE NO USE OF SAME WITHOUT PERMISSION		MATERIAL:
			DRAWN BY: D.O'CONNOR 2/11/14
			CHECKED BY:
		APPROVED BY:	

**HUBBELL** Hubbell Premise Wiring  
 HUBBELL INCORPORATED (Delaware)  
 23 CLARA DRIVE, SUITE 103 MYSTIC, CT 06355

TITLE:  
12 PORT PATCH PANEL, NEXTSPEED

SIZE: **D** DRAWING NO.: **HWS1439601C** REV.: **1**

SCALE: SHEET 1 OF 1