

CATALOG	DESCRIPTION
HP5E24A	NEXTSPEED CATEGORY 5e, 24 PORT ANGLED PATCH PANEL, BLACK
HP624A	NEXTSPEED CATEGORY 6, 24 PORT ANGLED PATCH PANEL, BLACK
HP6A24A	NEXTSPEED CATEGORY 6A, 24 PORT ANGLED PATCH PANEL, BLACK

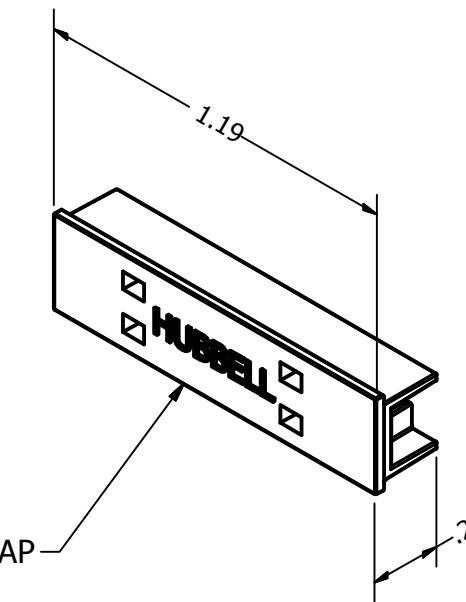

NOTES:

- PRODUCT INCLUDES
 - (1) PATCH PANEL ASSEMBLY
 - (25) STUFFER CAPS
 - (1) CABLE MANAGER BAR
 - (4) LABEL CARDS
 - (4) CLEAR LABEL COVERS
 - (1) HARDWARE PACK
 - (1) INSTRUCTIONS
- SPECIFICATIONS SUBJECT TO CHANGE WITHOUT NOTICE

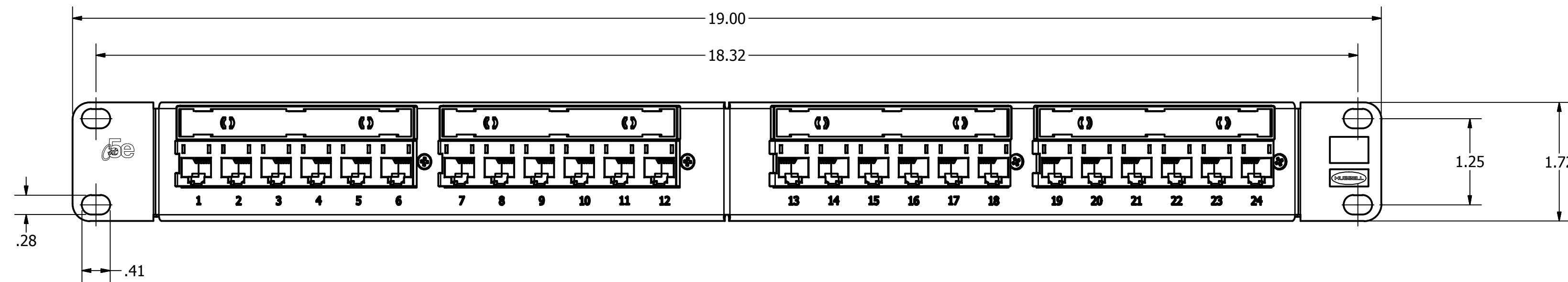
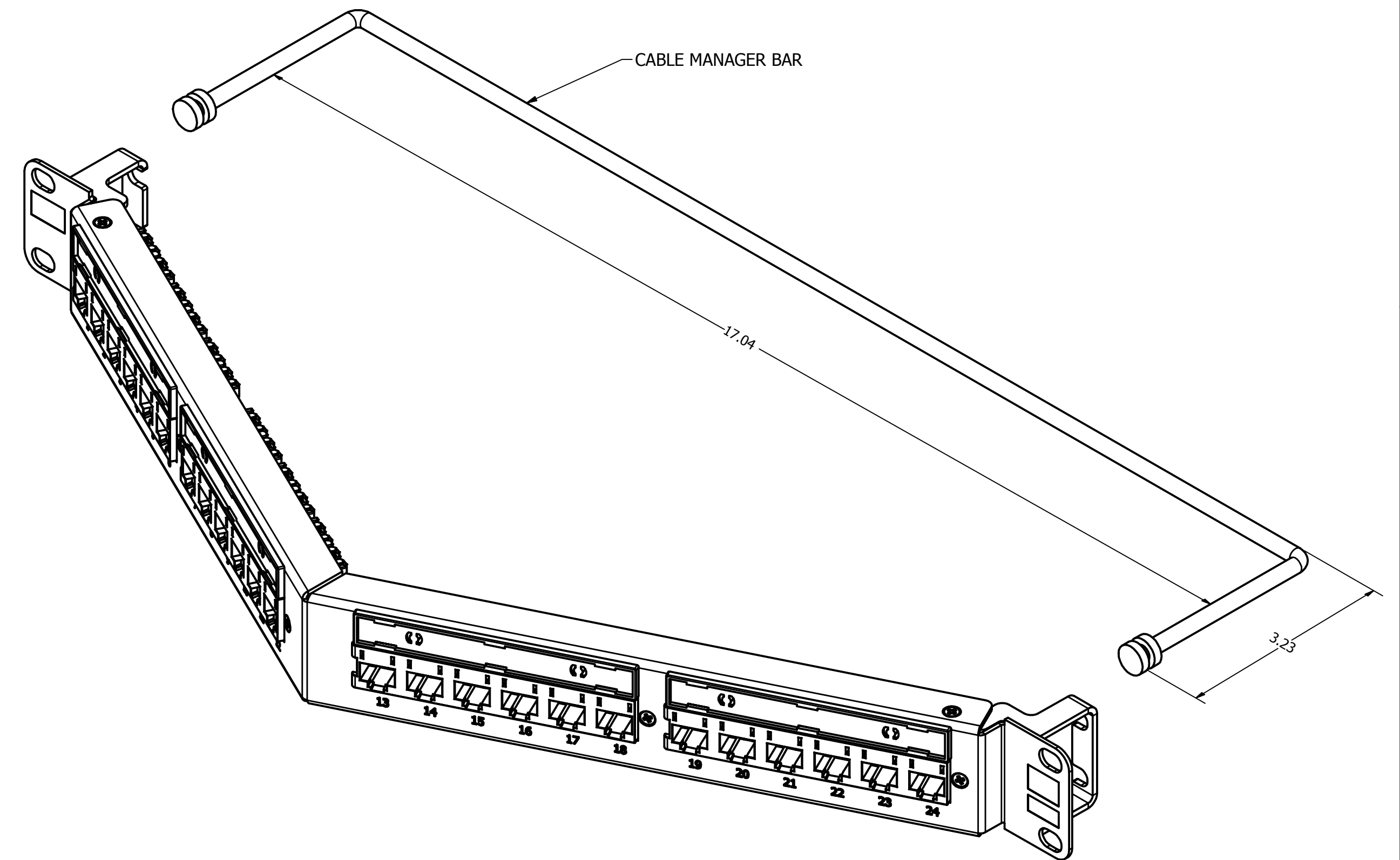
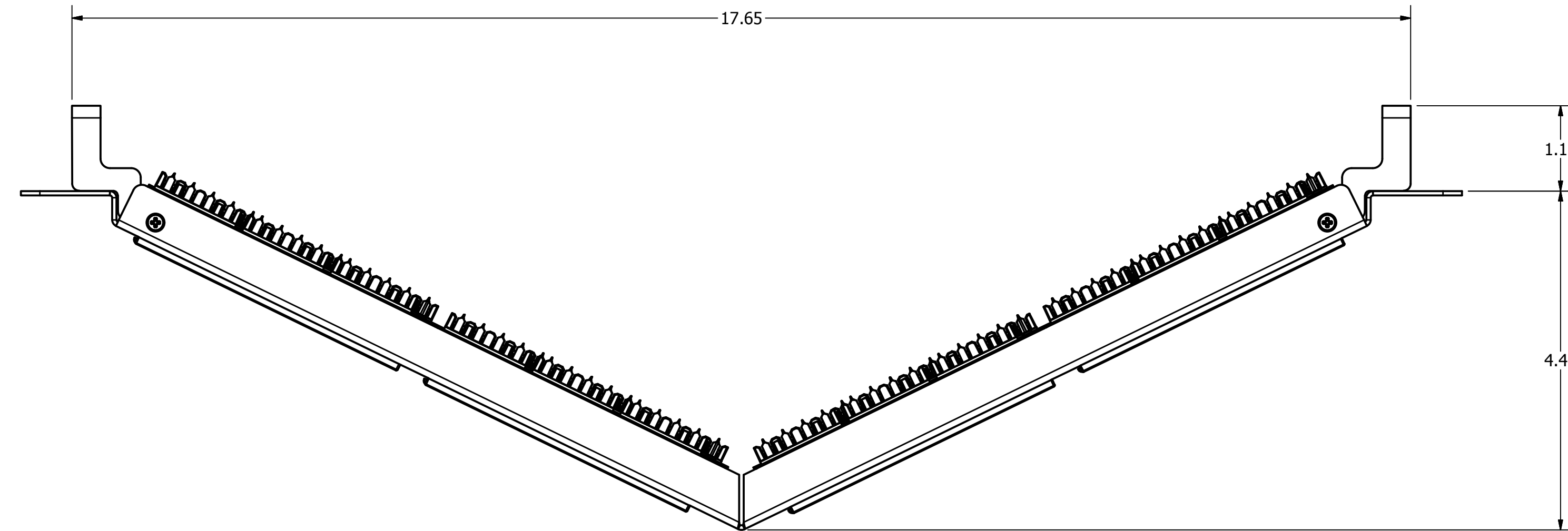
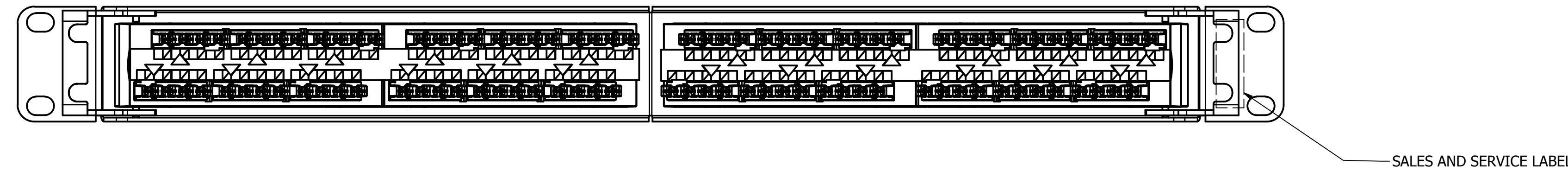

REV.	ECN	DATE	DESCRIPTION	CHG BY	APPD BY
1	17850	2/11/14	INITIAL RELEASE	DPO	

Created on INVENTOR

DIMENSIONING AND TOLERANCE PER ANSI Y14.5M-1982, UNLESS OTHERWISE SPECIFIED, DIMENSIONS ARE IN INCHES (MM). TOLERANCES: XX = ±.01 (.25)
 .XXX = ±.005 (.127)
 .XXXX = ±.0025 (.0635)
 ANGLE TOL ±1°

IN ACCEPTING OUR DRAWINGS, BLUEPRINTS, OR SUPPORTING DOCUMENTATION FOR QUOTATION OR OTHER PURPOSES, YOU AGREE NOT TO DISCLOSE TO OTHERS THE IDEAS, INFORMATION, OR DESIGNS SHOWN HEREIN, AND THAT YOU WILL MAKE NO USE OF SAME WITHOUT PERMISSION

PROJECT REFERENCE: 2013-017
MATERIAL:
DRAWN BY: D.O'CONNOR 2/11/14
CHECKED BY:
APPROVED BY:

HUBBELL Hubbell Premise Wiring
 HUBBELL INCORPORATED (Delaware)
 23 CLARA DRIVE, SUITE 103 MYSTIC, CT 06355

TITLE:
NEXTSPEED 24 PORT ANGLED PATCH PANEL

SIZE D	DRAWING NO. HWS14352C	REV. 1
SCALE: DNS	SHEET 1 OF 1	