

CATALOG NUMBER	HTAP	COVER
HYH6CWC	HYH6C6C	HCCFBGFR
HYH2CWC	HYH2C2C	HCCFOFR
HYH29WC	HYH292C	HCCFDFR
HYH2929WC	HYH2929	HCCFDFR

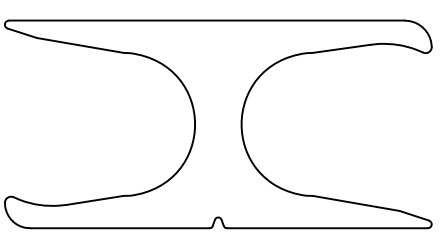

H-TAP

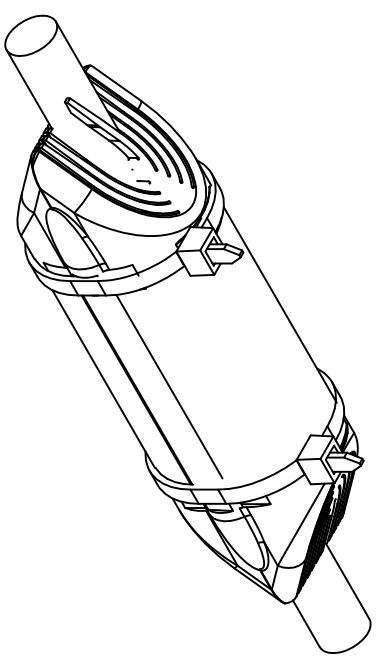

COVER

- NOTES:
1. KIT SHOULD CONTAIN:  
 (1) H-TAP, SEE TABULATION  
 (1) CLEAR COVER, SEE TABULATION

2. SPECIFICATIONS SUBJECT TO CHANGE WITHOUT NOTICE.

REV.	ECN	DATE	DESCRIPTION	CHG BY	APPD BY
1	18114	3/21/13	INITIAL RELEASE	MMA	

Created on AUTOCAD	
<p>DIMENSIONING AND TOLERANCE PER ANSI Y14.5M-1982 UNLESS OTHERWISE SPECIFIED, DIMENSIONS ARE IN INCHES (MM). TOLERANCES: .XX = ±.01 (.25) .XXX = ±.005 (.127) .XXXX = ±.0025 (.0635) ANGLE TOL .±1°</p>	<p>PROJECT REFERENCE: <b>2011-041</b></p> <p>MATERIAL: SEE NOTES</p>
<p>IN ACCEPTING OUR DRAWINGS, BLUEPRINTS, OR SUPPORTING DOCUMENTATION FOR QUOTATION OR OTHER PURPOSES, YOU AGREE NOT TO DISCLOSE TO OTHERS THE IDEAS, INFORMATION, OR DESIGNS SHOWN HEREIN, AND THAT YOU WILL MAKE NO USE OF SAME WITHOUT PERMISSION</p>	<p>DRAWN BY: M. ABBY 03/15/13</p> <p>CHECKED BY:</p> <p>APPROVED BY:</p>
<p>TITLE: KIT, HTAP WITH COVER</p>	<p>Hubbell Premise Wiring HUBBELL INCORPORATED (Delaware) 23 CLARA DRIVE, SUITE 103 MWSTIC, CT 06355</p>
<p>SIZE: <b>C</b></p> <p>DRAWING NO.: <b>HWS13067C</b></p> <p>SCALE: 1/1</p>	<p>REV. <b>1</b></p> <p>SHEET 1 OF 1</p>