

CATALOG NO.	DESCRIPTION	PERFORATION
MCCCWS19	19" CENTER WEIGHTED SHELF	NO
MCCCS19	19" CANTILEVERED SOLID SHELF	NO
MCCCS19P	19" CANTILEVERED PERFORATED	YES

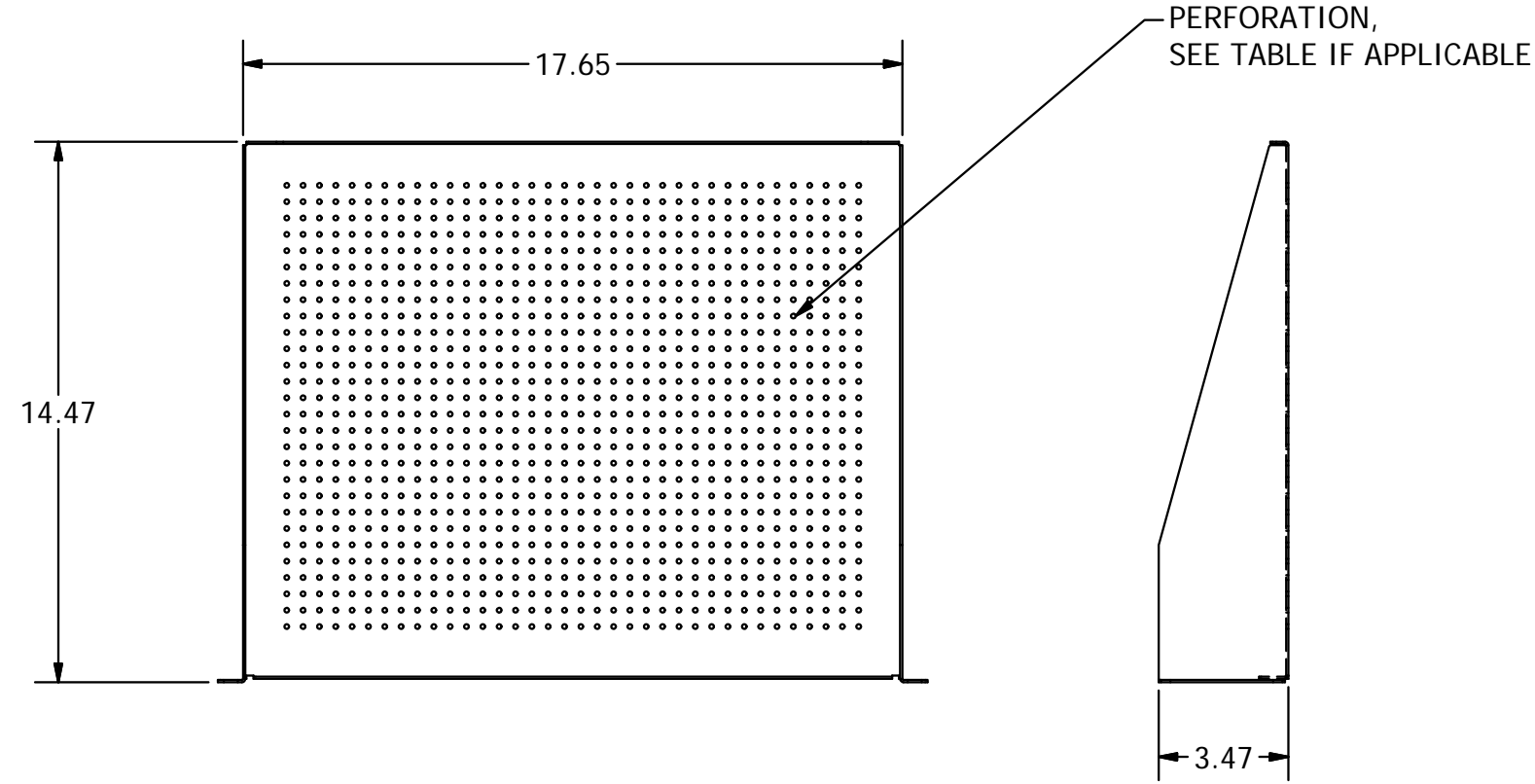

CANTILEVERED SHELF

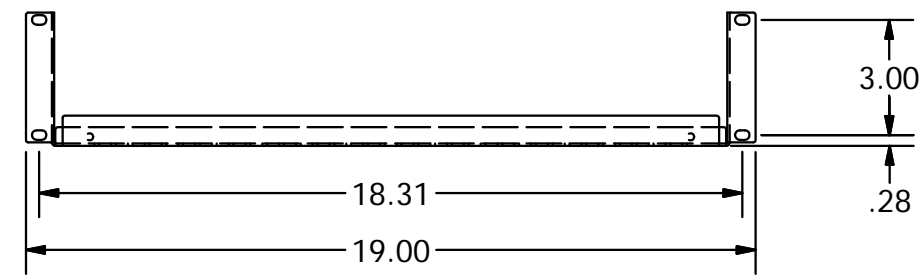
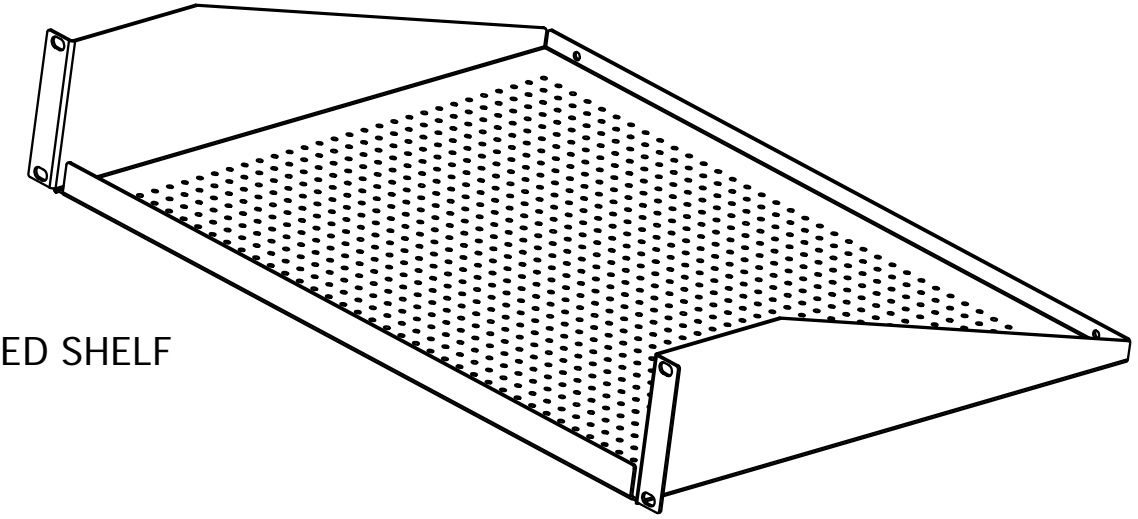

MOUNTING BRACKETS SHIP UNASSEMBLED

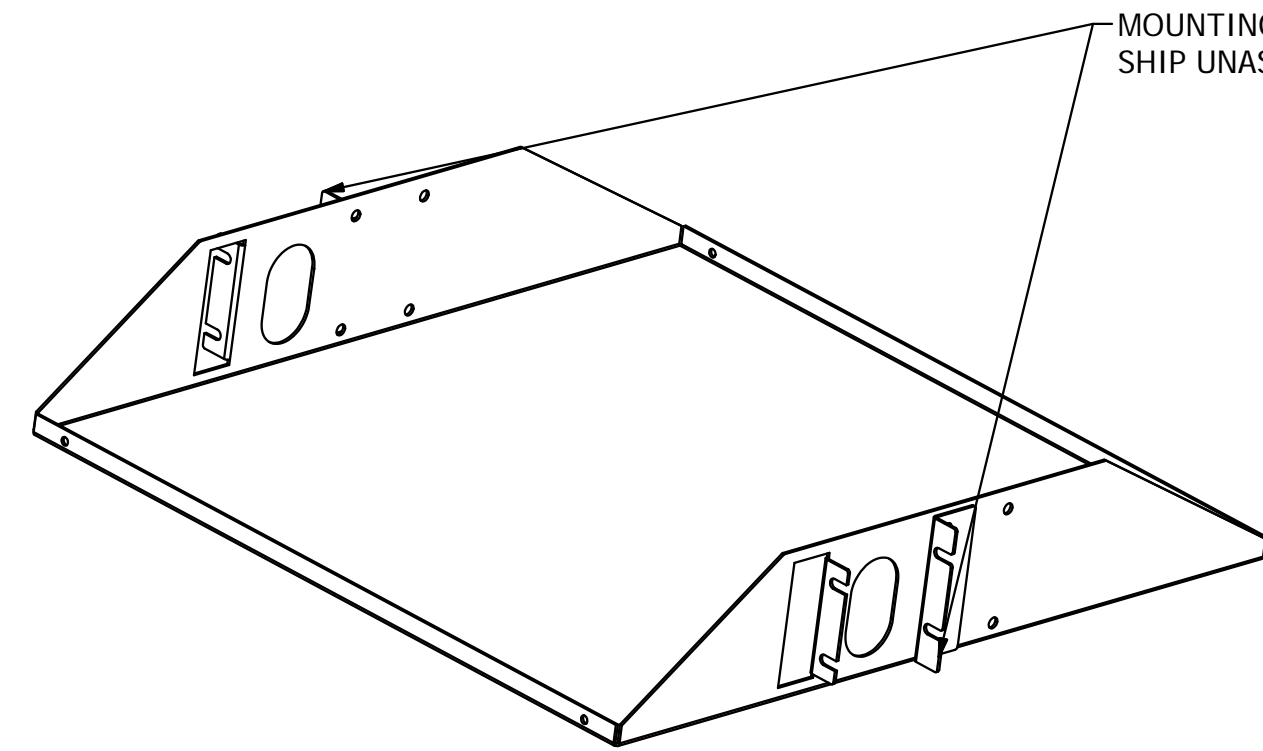

CENTER WEIGHTED SHELF

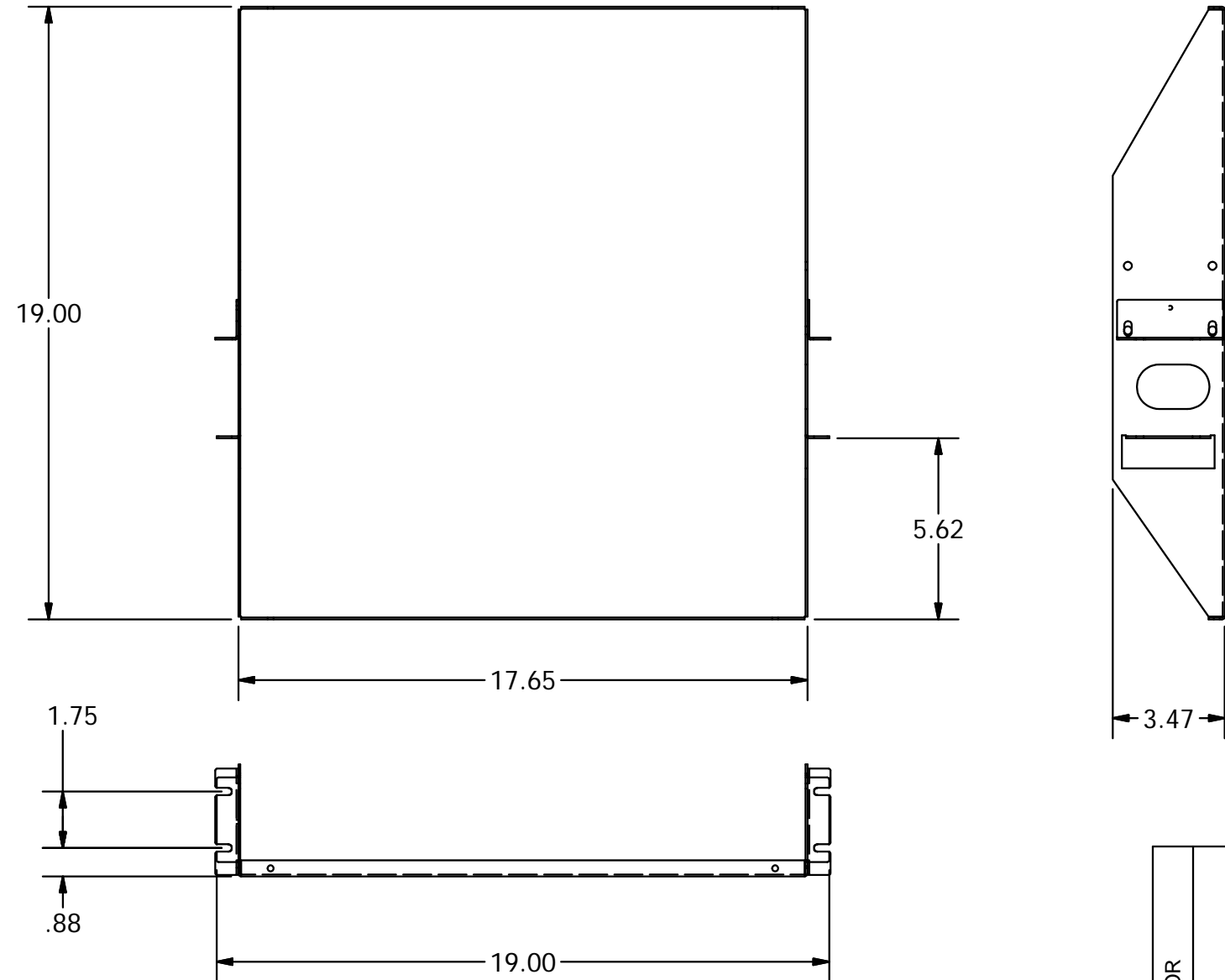

NOTES:

1. SURFACE FINISH: BLACK POWDER COAT
2. HARDWARE PACK INCLUDES (4) #12-24 SCREWS AND WASHERS AND (4) #10-32 SCREWS AND WASHERS.
3. SPECIFICATIONS SUBJECT TO CHANGE WITHOUT NOTICE.

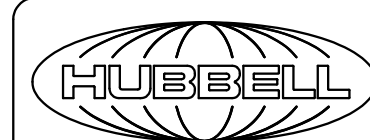
Created on INVENTOR	DIMENSIONING AND TOLERANCE PER ANSI Y14.5M-1982 UNLESS OTHERWISE SPECIFIED, DIMENSIONS ARE IN INCHES (MM). TOLERANCES: XX = ±.01 (.25) .XXX = ±.005 (.127) .XXXX = ±.0025 (.0635) ANGLE TOL ±1°		PROJECT REFERENCE:		 Hubbell Premise Wiring HUBBELL INCORPORATED (Delaware) 23 CLARA DRIVE, SUITE 103 MYSTIC, CT 06355		
	IN ACCEPTING OUR DRAWINGS, BLUEPRINTS, OR SUPPORTING DOCUMENTATION FOR QUOTATION OR OTHER PURPOSES, YOU AGREE NOT TO DISCLOSE TO OTHERS THE IDEAS, INFORMATION, OR DESIGNS SHOWN HEREIN, AND THAT YOU WILL MAKE NO USE OF SAME WITHOUT PERMISSION		MATERIAL: SEE COMPONENTS			TITLE: 19"W SHELF	
			DRAWN BY: MABBY 06/27/16		SIZE: C	DRAWING NO.: 11672C	REV.: 1
			CHECKED BY:		SCALE: N/A		SHEET 1 OF 1
		APPROVED BY:					

REV.	ECN	DATE	DESCRIPTION	CHG BY	APPD BY
1	21405	06/28/16	INITIAL RELEASE	MMA	DO