

ITEM NO.	DESCRIPTION	QTY.
1	1/4" STEREO JACK	1
2	SNAP FIT MODULE	1
3	PVC BOOT, BLACK	1

CATALOG NUMBER	COLOR	DESCRIPTION
SF14SJOW	OFFICE WHITE	1/4" STEREO JACK, SF
SF14SJBK	BLACK	1/4" STEREO JACK, SF
SF14SJGY	GRAY	1/4" STEREO JACK, SF
SF14SJEI	ELECTRIC IVORY	1/4" STEREO JACK, SF
SF14SJW	WHITE	1/4" STEREO JACK, SF
SF14SJAL	ALMOND	1/4" STEREO JACK, SF
SF14SJLA	LIGHT ALMOND	1/4" STEREO JACK, SF

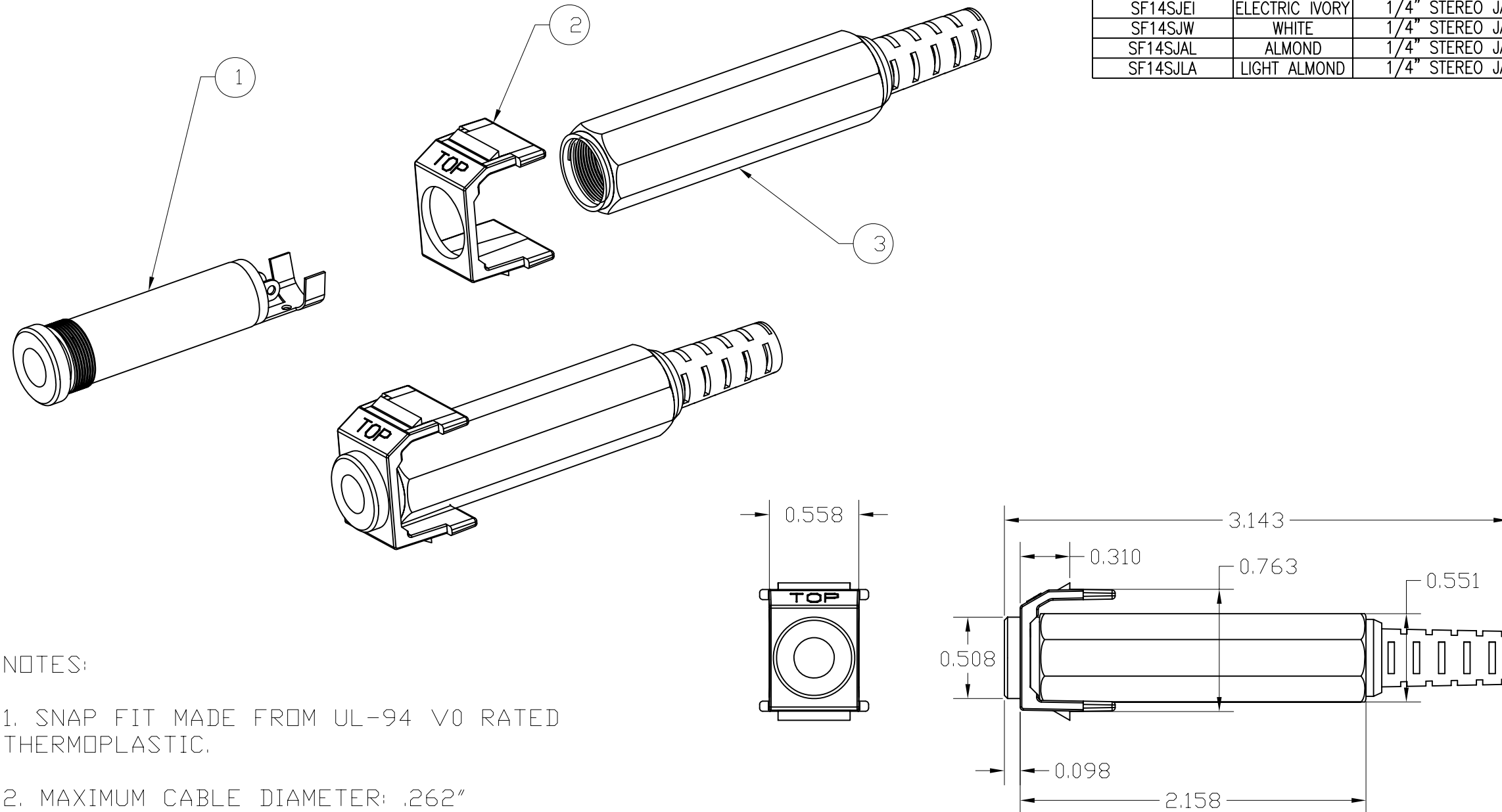

NOTES:

- SNAP FIT MADE FROM UL-94 V0 RATED THERMOPLASTIC.
- MAXIMUM CABLE DIAMETER: .262"
- 1/4" STEREO JACK TERMINAL WIRING:  
SILVER CONTACT: TIP  
GOLD CONTACT: RING  
CABLE CRIMP RING: SLEEVE
- SPECIFICATIONS SUBJECT TO CHANGE WITHOUT PRIOR NOTICE.

REV.	ECN	DATE	DESCRIPTION	CHG BY	APPD BY
B	6465	10/17/08	ADDED TERMINAL WIRING	DPO	

Created on AUTOCAD	DIMENSIONING AND TOLERANCE PER ANSI Y14.5M-1982 UNLESS OTHERWISE SPECIFIED, DIMENSIONS ARE IN INCHES (MM). TOLERANCES .XX = ±.01 (.25) .XXX = ±.005 (.127) .XXXX = ±.0025 (.0635) ANGLE TOL ±1°		PROJECT REFERENCE: 2005-020		 <b>Hubbell Premise Wiring</b> HUBBELL INCORPORATED (Delaware) 14 Lord's Hill Road, Stonington, Connecticut 06378
	IN ACCEPTING OUR DRAWINGS, BLUEPRINTS, OR SUPPORTING DOCUMENTATION FOR QUOTATION OR OTHER PURPOSES, YOU AGREE NOT TO DISCLOSE TO OTHERS THE IDEAS, INFORMATION, OR DESIGNS SHOWN HEREIN, AND THAT YOU WILL MAKE NO USE OF SAME WITHOUT PERMISSION		MATERIAL: N/A		
			DRAWN BY: D.O'CONNOR 9/29/06		TITLE: 1/4" STEREO JACK SNAP FITTING
			CHECKED BY:		SIZE: <b>C</b> DRAWING NO.: <b>HWS12465C</b> REV.: <b>B</b>
		APPROVED BY:		SCALE: 1/1 SHEET 1 OF 1	