

CATALOG NO.	DESCRIPTION	"A"
VCW1010	CABLE MANAGEMENT GATES FOR 10"DP RACK	8.00
VCW1610	CABLE MANAGEMENT GATES FOR 16"DP RACK	14.00

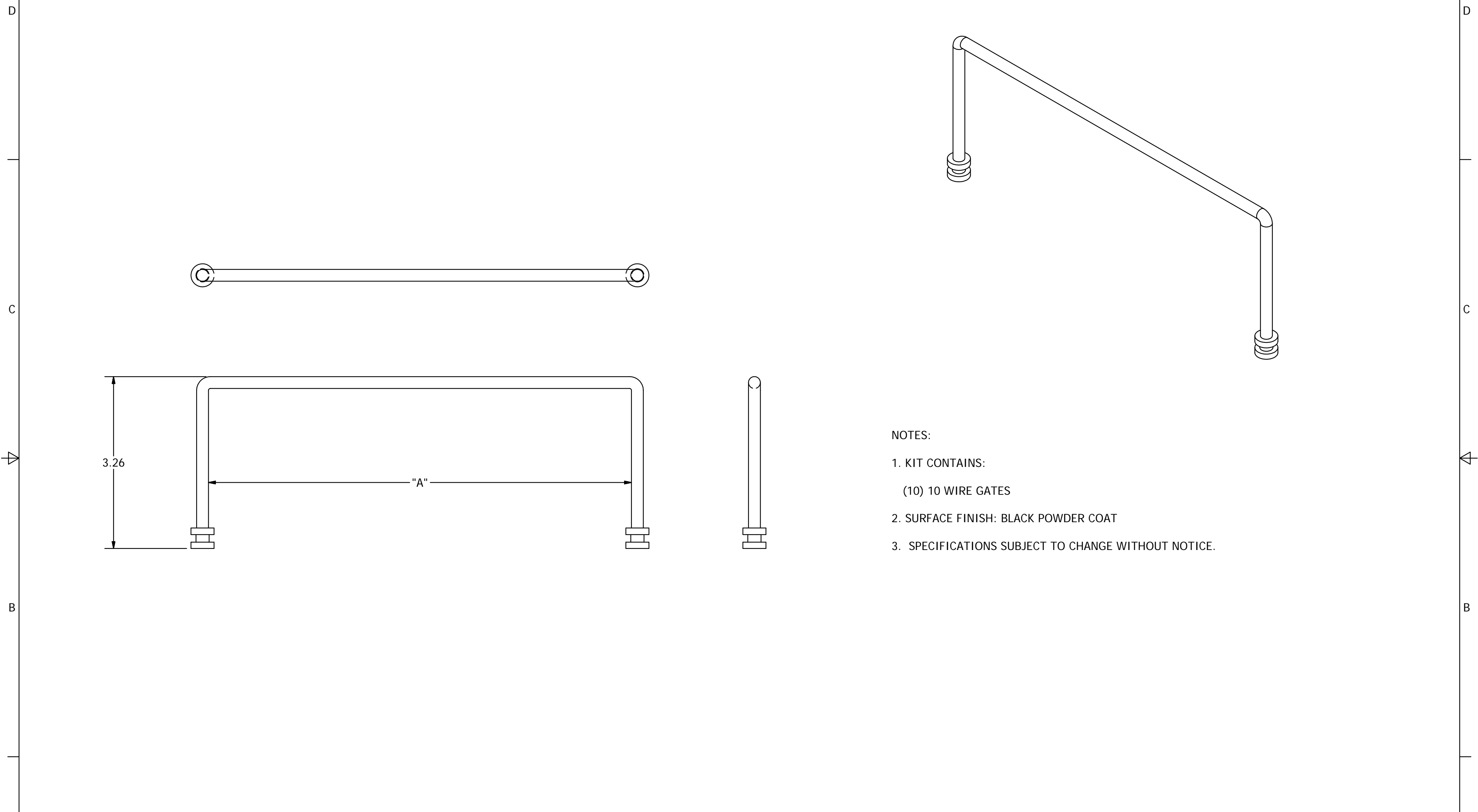

NOTES:

- KIT CONTAINS:
(10) 10 WIRE GATES
- SURFACE FINISH: BLACK POWDER COAT
- SPECIFICATIONS SUBJECT TO CHANGE WITHOUT NOTICE.

REV.	ECN	DATE	DESCRIPTION	CHG BY	APPD BY
1	21405	07/07/16	INITIAL RELEASE	MMA	DO

Created on INVENTOR

DIMENSIONING AND TOLERANCE PER ANSI Y14.5M-1982
UNLESS OTHERWISE SPECIFIED, DIMENSIONS ARE IN INCHES (MM).
TOLERANCES: XX = ±.01 (.25)
.XXX = ±.005 (.127)
.XXXX = ±.0025 (.0635)
ANGLE TOL ±1°

IN ACCEPTING OUR DRAWINGS, BLUEPRINTS, OR SUPPORTING DOCUMENTATION FOR QUOTATION OR OTHER PURPOSES, YOU AGREE NOT TO DISCLOSE TO OTHERS THE IDEAS, INFORMATION, OR DESIGNS SHOWN HEREIN, AND THAT YOU WILL MAKE NO USE OF SAME WITHOUT PERMISSION

PROJECT REFERENCE: NPD00048
MATERIAL: STEEL WIRE
DRAWN BY: D.O'CONNOR 07/07/16
CHECKED BY:
APPROVED BY:

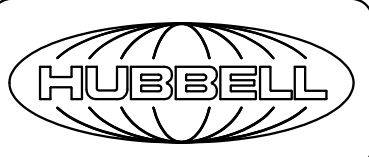
 Hubbell Premise Wiring HUBBELL INCORPORATED (Delaware) 23 CLARA DRIVE, SUITE 103 MYSTIC, CT 06355		TITLE: WIRE GATE PACK	
		SIZE C	DRAWING NO. HWS14532C
SCALE: N/A		SHEET 1 OF 1	