

**DETAIL A (3 PL.)**  
**(LID ATTACHMENT DETAIL)**

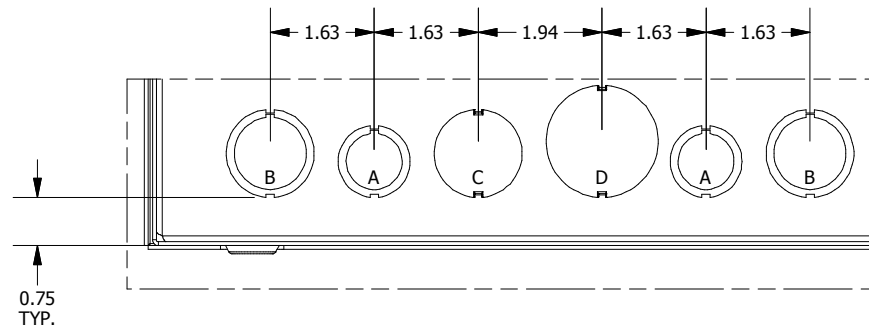

**DETAIL B (3 PL.)**  
**(K.O. PATTERN)**

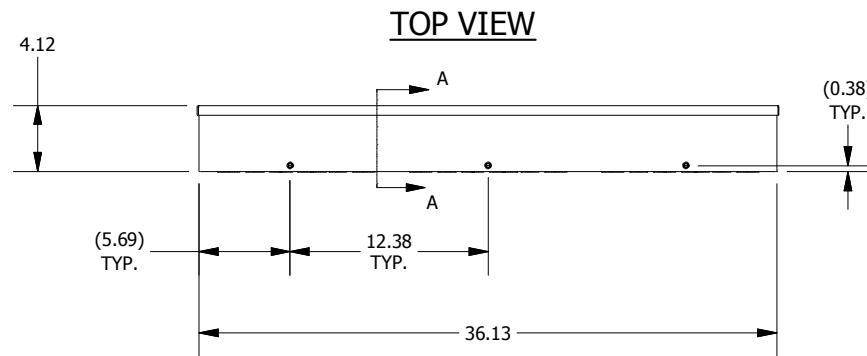
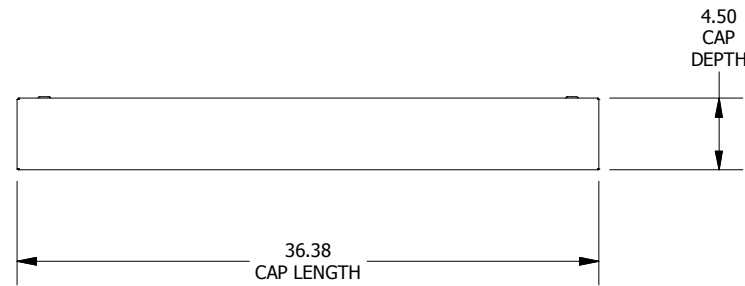
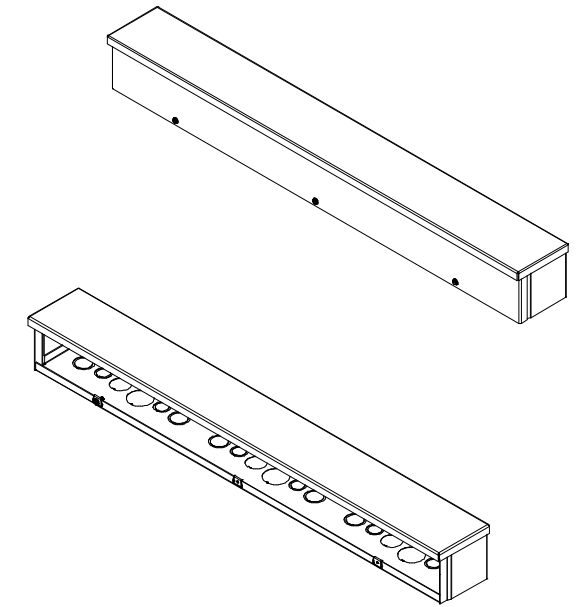

**FRONT VIEW**

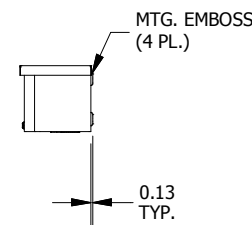

**RIGHT SIDE VIEW**

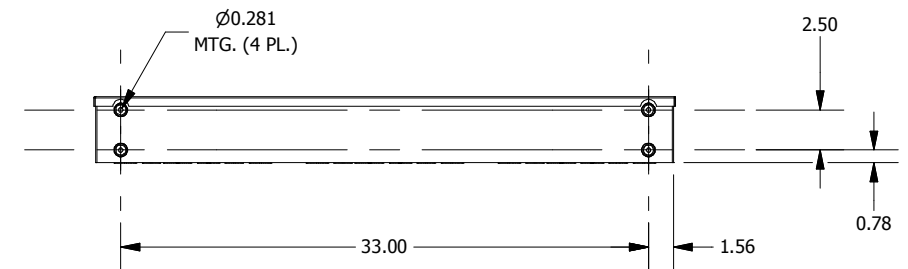

**BACK VIEW**

**SECTION A-A**  
**(INSIDE RIGHT OF ENCL.)**

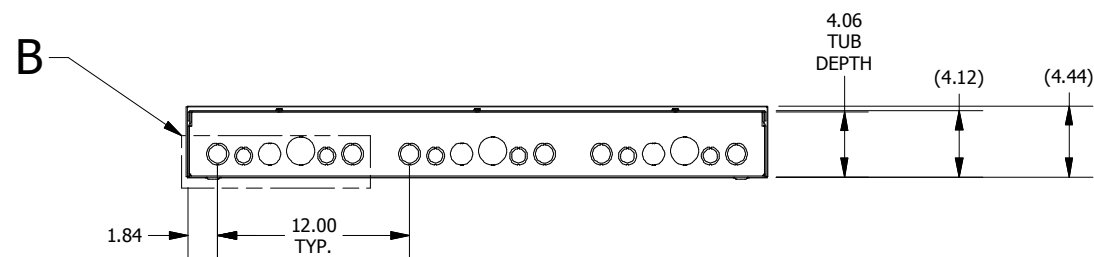

**BOTTOM VIEW**

KNOCKOUT SIZE TABLE	
SIZE	DESCRIPTION
A	1/2" TO 3/4" CONCENTRIC K.O.
B	3/4" TO 1" CONCENTRIC K.O.
C	1" SOLID K.O.
D	1-1/4" SOLID K.O.

PART#: RSCG040436  
(DATA SUBJECT TO CHANGE WITHOUT NOTICE)

THIS DRAWING IS PROPERTY OF HUBBELL INC. WIEGMANN  
ALL INFORMATION IS PROPRIETARY AND NOT TO BE DUPLICATED