

ITEM NO.	DESCRIPTION	QTY.
1	LC CONNECTOR DUST CAP	2
2	LC DUPLEX CONNECTOR BODY	1
3	LC CONNECTOR BOOT	2
4	DUPLEX CABLE	A/R
5	SC CONNECTOR BOOT	2
6	SC DUPLEX CLIP	1
7	SC CONNECTOR NUT	2
8	SC CONNECTOR DUST CAP	2

CATALOG NO.	DESCRIPTION	CABLE JACKET COLOR
DFRCLCSCDxxMM	LC-SC DUPLEX PATCH CORD 50/125um OM2 MULTIMODE	ORANGE
DFRCLCSCExxMM	LC-SC DUPLEX PATCH CORD 50/125um OM3 MULTIMODE	AQUA
DFRCLCSCFxxMM	LC-SC DUPLEX PATCH CORD 50/125um OM4 MULTIMODE	AQUA

xx = LENGTH IN METERS

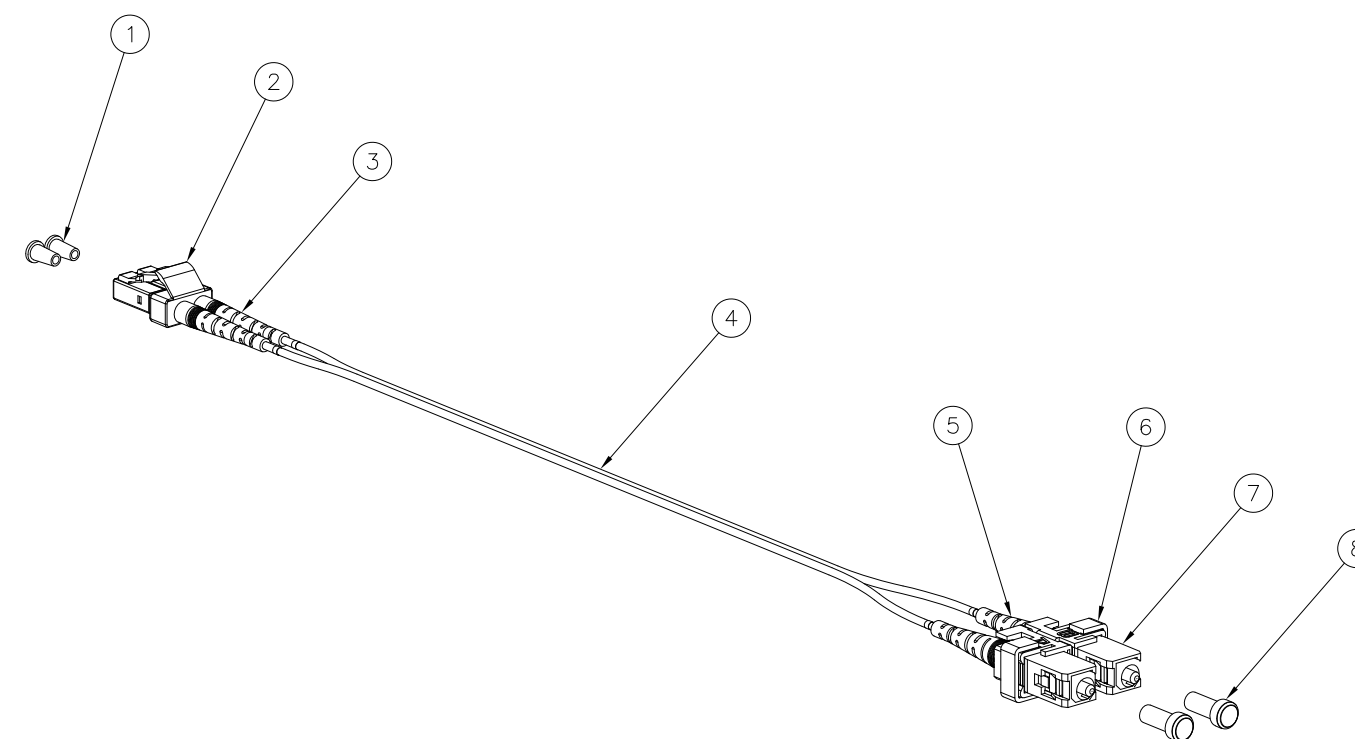
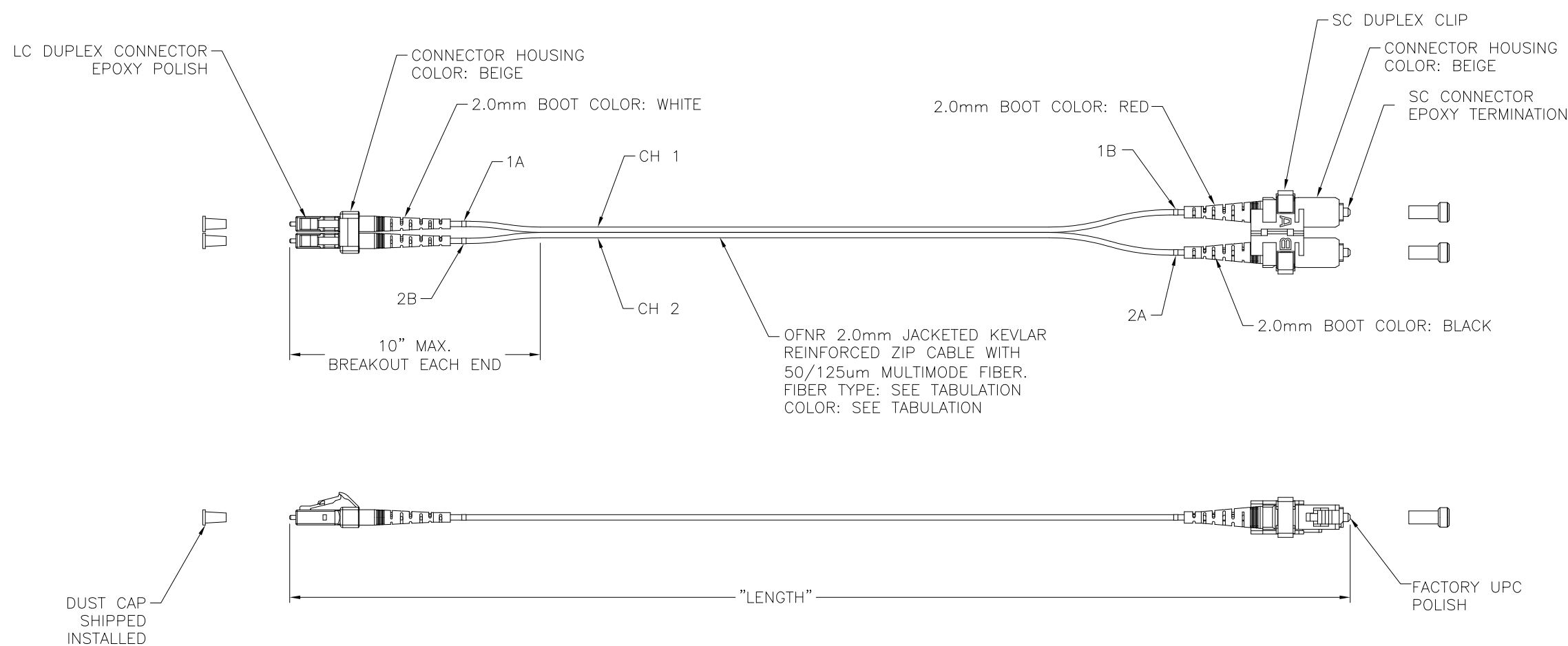

- NOTES:
- CONNECTOR OPTICAL, MECHANICAL AND ENVIRONMENTAL PERFORMANCE MEETS TIA568-C.3 SPECIFICATIONS.
  - CONNECTOR USES A PC RADIUS TIP ZIRCONIA CERAMIC FERRULE.
  - CONNECTOR HOUSINGS ARE INJECTION MOLDED ENGINEERING PLASTIC RESIN.
  - OPTICAL INSERTION LOSS TEST DATA INCLUDED IN EACH BAGGED PATCH CORD.
  - CABLE MARKINGS TO IDENTIFY CHANNEL (1 OR 2) AND EACH END (A OR B).
  - SPECIFICATIONS SUBJECT TO CHANGE WITHOUT PRIOR NOTICE.

REV.	ECN	DATE	DESCRIPTION	CHG BY	APPD BY
1	23955	06/03/20	REVISED BOOT COLORS	AK	DPO

Created on AUTOCAD	DIMENSIONING AND TOLERANCE PER ANSI Y14.5M-1992, UNLESS OTHERWISE SPECIFIED, DIMENSIONS ARE IN INCHES (MM). TOLERANCES .XX = ±.01 (.25) .XXX = ±.005 (.127) .XXXX = ±.0025 (.0635) ANGLE TOL ±1°	PROJECT REFERENCE:	 <b>Hubbell Premise Wiring</b> HUBBELL INCORPORATED (Delaware) 14 Lord's Hill Road, Stonington, Connecticut 06378
	IN ACCEPTING OUR DRAWINGS, BLUEPRINTS, OR SUPPORTING DOCUMENTATION FOR QUOTATION OR OTHER PURPOSES, YOU AGREE NOT TO DISCLOSE TO OTHERS THE IDEAS, INFORMATION, OR DESIGNS SHOWN HEREIN, AND THAT YOU WILL MAKE NO USE OF SAME WITHOUT PERMISSION	MATERIAL:	
	DRAWN BY: D. PECK 3/5/13	CHECKED BY:	SIZE: D
	APPROVED BY:		DRAWING NO.: <b>HWS14271C</b>
			SCALE: N/A
			SHEET 1 OF 1
			REV. <b>1</b>