

| CATALOG | DESCRIPTION                                     | COVER QTY | DEPTH |
|---------|---|-----------|-------|
| HS23    | 2U 3" DP HORIZONTAL CABLE ORGANIZER, NO COVER   | N/A       | 3.00  |
| HS23C   | 2U 3" DP HORIZONTAL CABLE ORGANIZER, WITH COVER | 1         | 3.00  |
| HS26C   | 2U 6" DP HORIZONTAL CABLE ORGANIZER, WITH COVER | 1         | 6.00  |

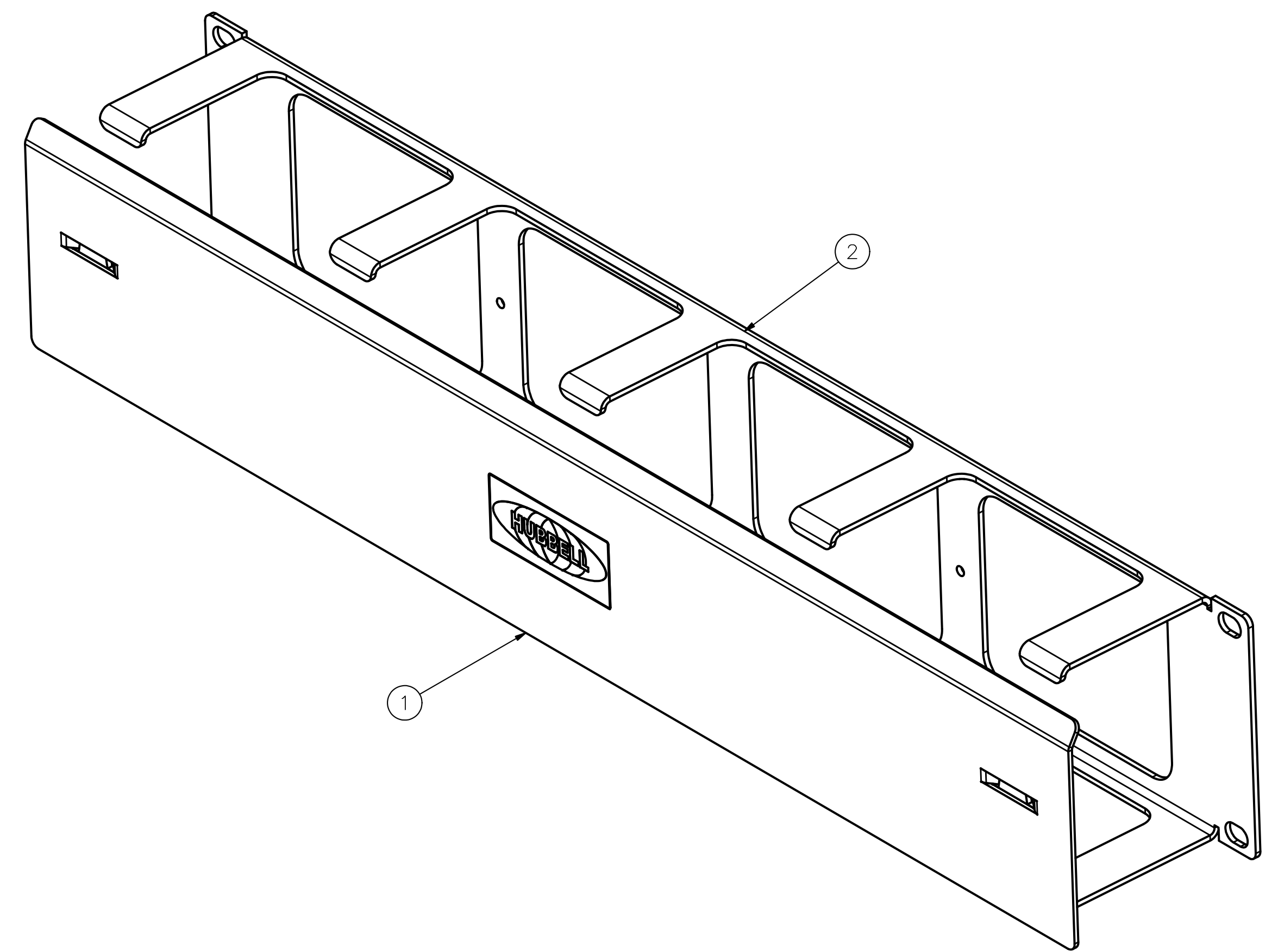
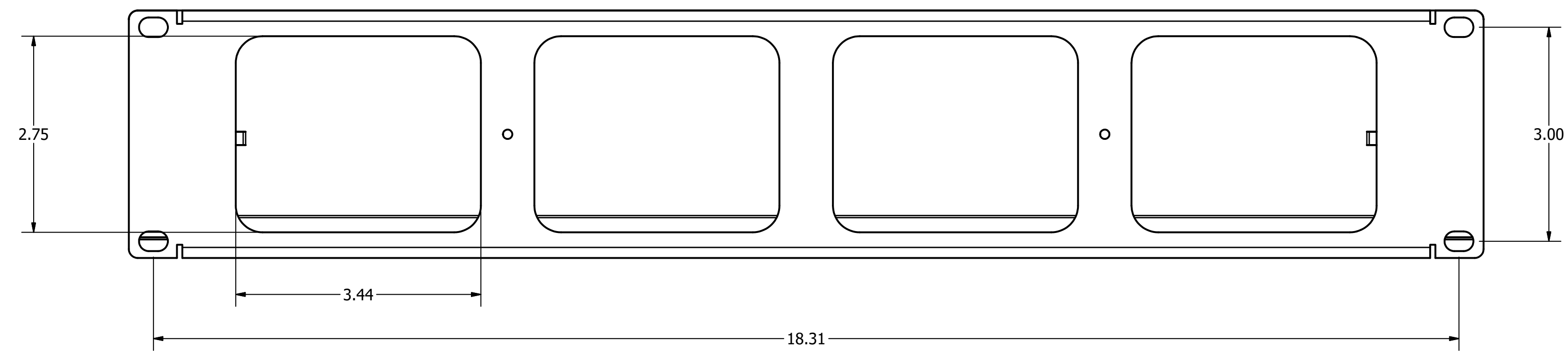
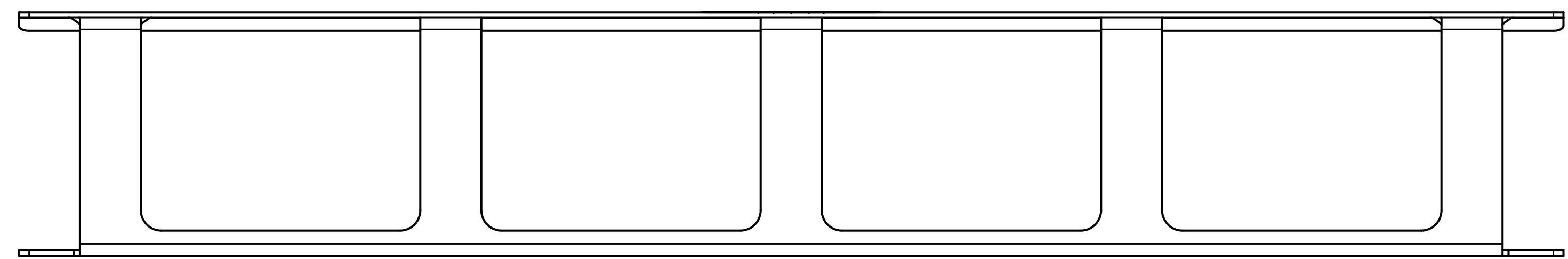
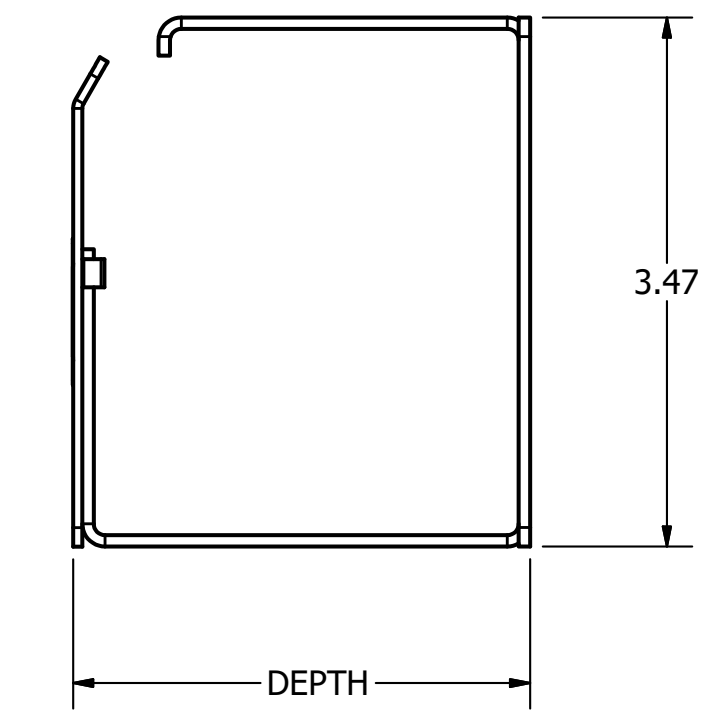
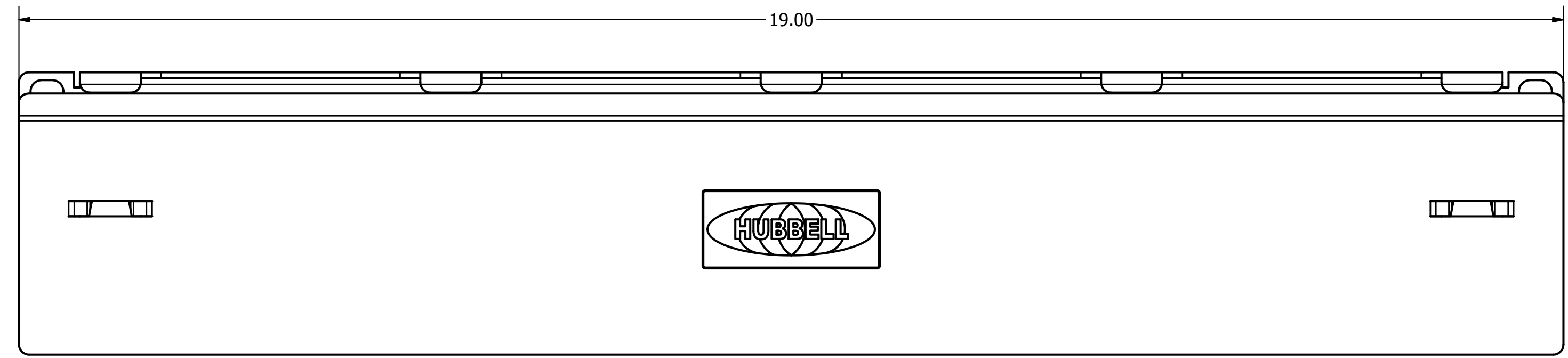

NOTES:

1. FINISH: BLACK POWDER COAT
2. MATERIAL: COVER 16Ga. CRS, ORGANIZER 14Ga. CRS
3. SPECIFICATIONS SUBJECT TO CHANGE WITH OUT NOTICE.

|      |                      |     |
|------|----------------------|-----|
| 3    | #12-24 HARDWARE PACK | 1   |
| 2    | BASE                 | 1   |
| 1    | COVER                | "N" |
| ITEM | DESCRIPTION          | QTY |

|                     |   |  |                                |
|---------------------|---|--|--------------------------------|
| Created on INVENTOR | DIMENSIONING AND TOLERANCE PER ANSI Y14.5M-1982 UNLESS OTHERWISE SPECIFIED, DIMENSIONS ARE IN INCHES (MM). TOLERANCES:XX = ±.01 (.25) .XXX = ±.005 (.127) .XXXX = ±.0025 (.0635) ANGLE TOL ±1°  |  | PROJECT REFERENCE:<br>2012-014 |
|                     | IN ACCEPTING OUR DRAWINGS, BLUEPRINTS, OR SUPPORTING DOCUMENTATION FOR QUOTATION OR OTHER PURPOSES, YOU AGREE NOT TO DISCLOSE TO OTHERS THE IDEAS, INFORMATION, OR DESIGNS SHOWN HEREIN, AND THAT YOU WILL MAKE NO USE OF SAME WITHOUT PERMISSION |  | MATERIAL:<br>C.R.S.            |
|                     | DRAWN BY:<br>D.O'CONNOR 5/14/14   | TITLE:<br>2U HORIZONTAL CABLE ORGANIZER ASSEMBLY |                                |
|                     | CHECKED BY:   | SIZE DRAWING NO.<br>D HWS14418C                  |                                |
| APPROVED BY:        | SCALE: NTS  |  | REV. 3                         |

**HUBBELL** Hubbell Premise Wiring  
HUBBELL INCORPORATED (Delaware)  
23 CLARA DRIVE, SUITE 103 MYSTIC, CT 06355

| REV. | ECN   | DATE     | DESCRIPTION            | CHG BY | APPD BY |
|------|-------|----------|------------------------|--------|---------|
| 3    | 23901 | 12/13/19 | ADDED 6" VDEEP VERSION | MMA    | DO      |

SCALE: NTS SHEET 1 OF 1