

FRONT VIEW

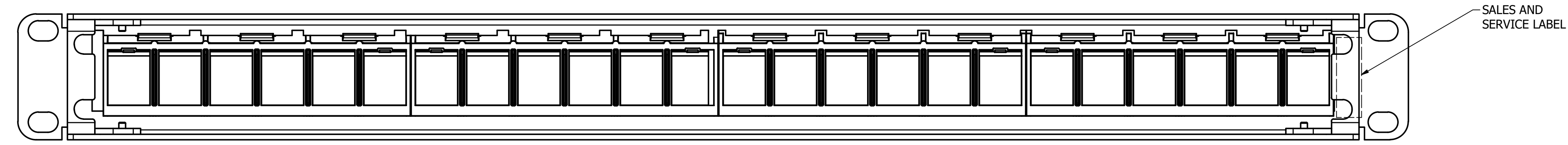
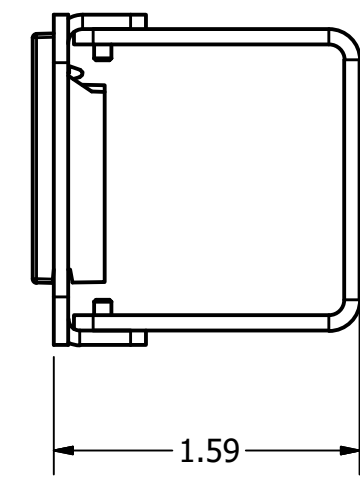

REAR VIEW

- NOTES:
- PRODUCT INCLUDES
 - (1) PATCH PANEL ASSEMBLY
 - (4) LABEL CARDS
 - (4) CLEAR LABEL COVERS
 - (1) HARDWARE PACK
 - (1) INSTRUCTIONS
 - (1) HJU6A24BK, 24 PACK C6A JACKS
 - (1) CABLE MANAGER BAR
 - SPECIFICATIONS SUBJECT TO CHANGE WITHOUT NOTICE

Created on INVENTOR	DIMENSIONING AND TOLERANCE PER ANSI Y14.5M-1982 UNLESS OTHERWISE SPECIFIED, DIMENSIONS ARE IN INCHES (MM). TOLERANCES: XX = ±.01 (.25) .XXX = ±.005 (.127) .XXXX = ±.0025 (.0635) ANGLE TOL ±1°		PROJECT REFERENCE: NPD-02962		Hubbell Premise Wiring HUBBELL INCORPORATED (Delaware) 23 CLARA DRIVE, SUITE 103 MYSTIC, CT 06355		
	IN ACCEPTING OUR DRAWINGS, BLUEPRINTS, OR SUPPORTING DOCUMENTATION FOR QUOTATION OR OTHER PURPOSES, YOU AGREE NOT TO DISCLOSE TO OTHERS THE IDEAS, INFORMATION, OR DESIGNS SHOWN HEREIN, AND THAT YOU WILL MAKE NO USE OF SAME WITHOUT PERMISSION		MATERIAL:			TITLE: 24 PORT UNLOADED PANEL KIT W/C6A JACKS	
			DRAWN BY: D.O'CONNOR 9/12/19		SIZE: D	DRAWING NO.: HWS14893C	REV.: 1
			CHECKED BY:		SCALE:		SHEET 1 OF 1

REV.	ECN	DATE	DESCRIPTION	CHG BY	APPD BY
1	23840	9/12/19	INITIAL RELEASE	DPO	MMA

