

ITEM NO.	DESCRIPTION	QTY.
1	CENTER BODY	1
2	REAR DOOR ASSEMBLY	1
3	FRONT DOOR ASSEMBLY	1
4	19" RACK RAILS	2

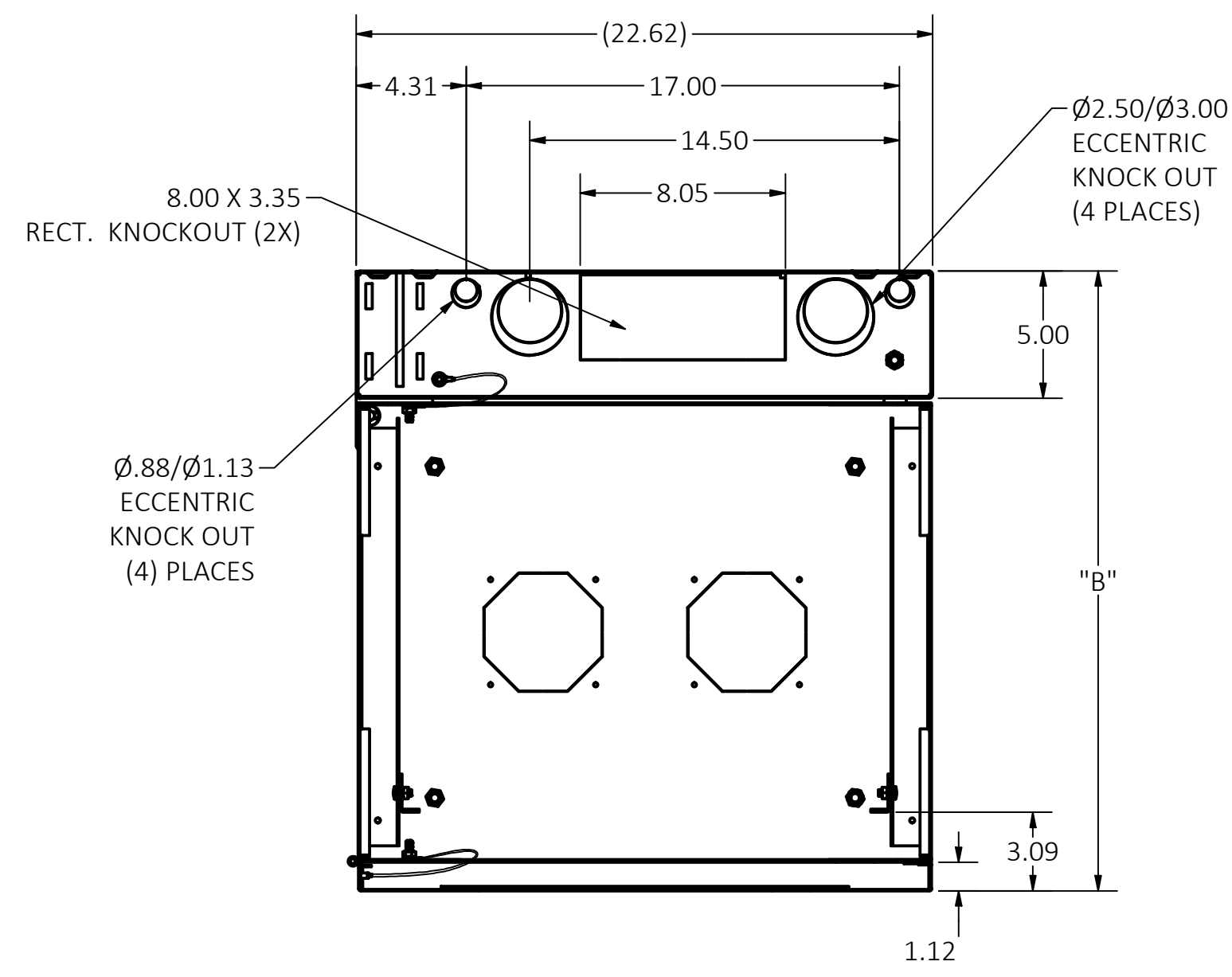

SECTION C-C

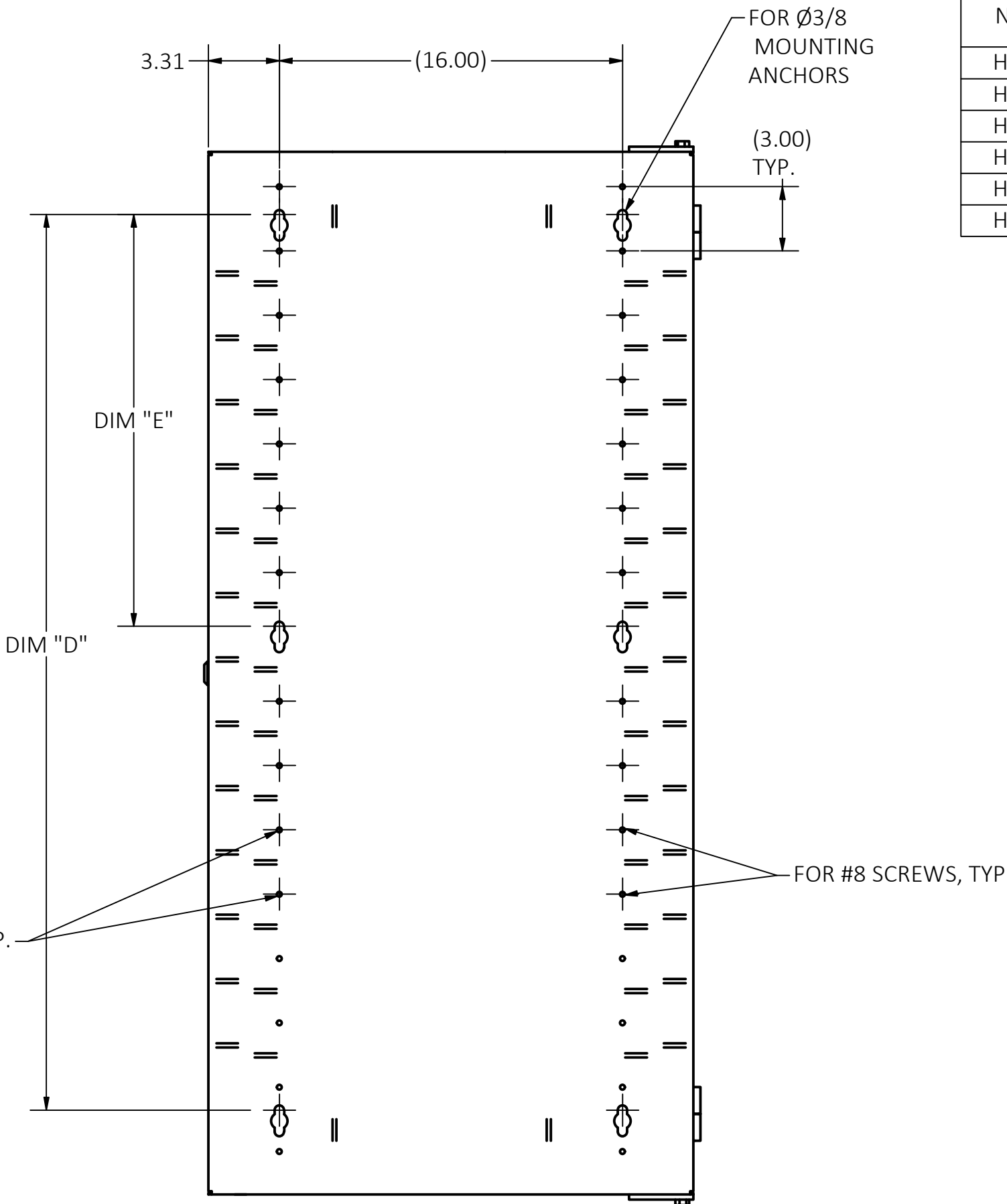

WALL MOUNTING PATTERN

CATALOG NUMBER	DESCRIPTION	COLOR	RACK POSITIONS	HEIGHT "A"	DEPTH "B"	OVERALL HEIGHT DIM "C"	DIM "D"	DIM "E"
HQC2424	HQC, 24H X 24D, WINDOW DR, BLACK	BLACK	12	24.12	24.33	25.12	17.77	N/A
HQC3624	HQC, 36H X 24D, WINDOW DR, BLACK	BLACK	19	36.37	24.33	37.37	29.52	N/A
HQC4824	HQC, 48H X 24D, WINDOW DR, BLACK	BLACK	26	48.62	24.33	49.62	41.77	19.20
HQC2432	HQC, 24H X 32D, WINDOW DR, BLACK	BLACK	12	24.12	32.33	25.12	17.77	N/A
HQC3632	HQC, 36H X 32D, WINDOW DR, BLACK	BLACK	19	36.37	32.33	37.37	29.52	N/A
HQC4832	HQC, 48H X 32D, WINDOW DR, BLACK	BLACK	26	48.62	32.33	49.62	41.77	19.20

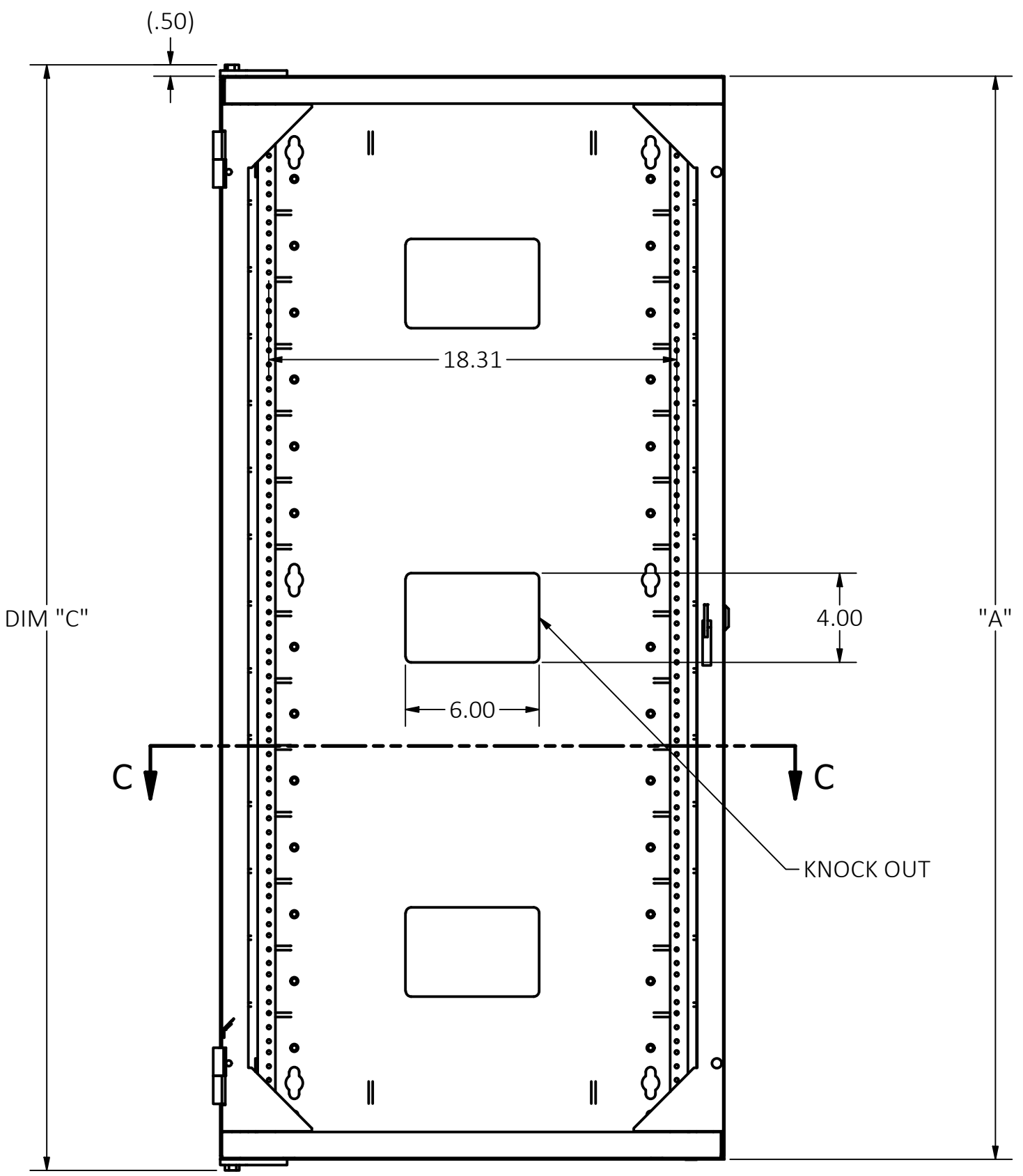
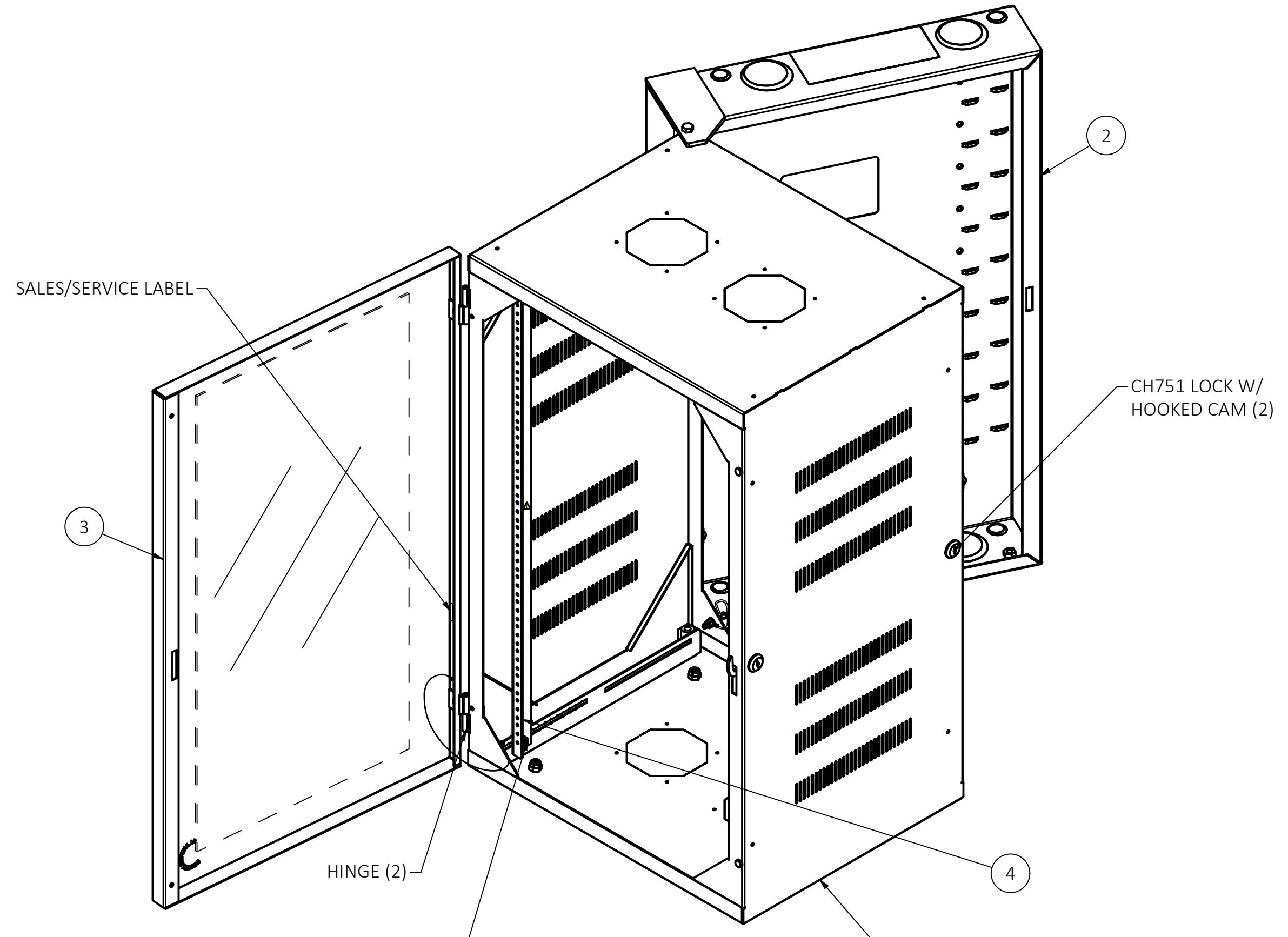

FRONT VIEW (FRONT DOOR NOT SHOWN)

- NOTES:
- CABINET SHIPS FULLY ASSEMBLED
 - 19" MOUNTING RAILS ARE EIA 310-D COMPLAINT : TAPPED #12-24 UNIVERSAL SPACING
 - 300lb LOAD CAPACITY
 - SUGGESTED SIZE FOR WALL MOUNTING HARDWARE IS 3/8 HARDWARE
 - SPECIFICATION SUBJECT TO CHANGE WITHOUT NOTICE

REV.	ECN	DATE	DESCRIPTION	CHG BY	APPD BY
1	240118036151	04/23/24	INITIAL RELEASE	RSS	MMA

<p>Created on INVENTOR</p> <p>IN ACCEPTING OUR DRAWINGS, BLUEPRINTS, OR SUPPORTING DOCUMENTATION FOR QUOTATION OR OTHER PURPOSES, YOU AGREE NOT TO DISCLOSE TO OTHERS THE IDEAS, INFORMATION, OR DESIGNS SHOWN HEREIN, AND THAT YOU WILL MAKE NO USE OF SAME WITHOUT PERMISSION</p>	<p>DIMENSIONING AND TOLERANCE PER ANSI Y14.5M-1982 UNLESS OTHERWISE SPECIFIED, DIMENSIONS ARE IN INCHES (MM). TOLERANCES: XX = ±.01 (.25) XXX = ±.005 (.127) .XXXX = ±.0025 (.0635) ANGLE TOL ±1°</p>	<p>PROJECT REFERENCE:</p> <p>MATERIAL:</p> <p>DRAWN BY: S RUBAN 1/18/2024</p> <p>CHECKED BY:</p> <p>APPROVED BY:</p>	<p>HUBBELL</p> <p>Hubbell Premise Wiring HUBBELL INCORPORATED (Delaware) 23 CLARA DRIVE, SUITE 103 MYSTIC, CT 06355</p>
	<p>IN ACCEPTING OUR DRAWINGS, BLUEPRINTS, OR SUPPORTING DOCUMENTATION FOR QUOTATION OR OTHER PURPOSES, YOU AGREE NOT TO DISCLOSE TO OTHERS THE IDEAS, INFORMATION, OR DESIGNS SHOWN HEREIN, AND THAT YOU WILL MAKE NO USE OF SAME WITHOUT PERMISSION</p>	<p>TITLE: HQC QUADCAB ASSEMBLY</p> <p>SIZE: D DRAWING NO. HWS15274C</p> <p>SCALE: SCALE SHEET 1 OF 1</p>	<p>REV. 1</p>