

4

3

2

1

ENCLOSURE INFORMATION

P/N:	DESCRIPTION:
23830KBAM	BOX SST 1F 1q, M20 BOTTOM
23803ABAB	COVER SST 1F 1q, SINGLE DEVICE
23203AAMB	ASSY, DIN RAIL HKH 1 TIER

PILOT LIGHT RATINGS:
 LIGHT EMITTING DIODE
 12-254 VAC/DC LED
 0.6WTERMINALS RATED FOR 1-2 CONDUCTORS
 #22-10 AWG. (0.5-4mm²)

DEVICE 1 ASSEMBLY (1F)

P/N:	DESCRIPTION:
HKHPLR	PILOT LIGHT RED LENS ASSEMBLY
23225AAMB	Blank
N/A	N/A
HKHPLD	PILOT LIGHT MOD. DM

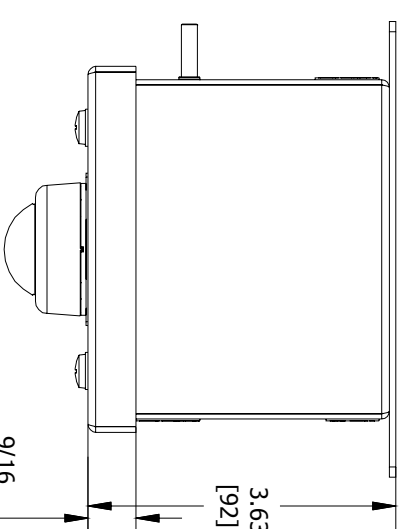

TOP VIEW

		CAT. NO. HKHMOD Series	DATE CODE-S/N
Harsh & Hazardous www.harschandhazardous.com		INDUSTRIAL CONTROL EQUIPMENT FOR USE IN ZONE CLASSIFIED HAZ. LOCs. CLASS I, ZONE 1, AEx de IIC T6...T4 Gb Ex de IIC T6...T4 Gb CLASS I, DIV. 2, GRPS. A,B,C,D; CLASS II, DIV.1, GRPS. E,F,G (CANADA ONLY) CLASS III; TYPE 3/4/4X/12/13; -50°C ≤Tas+60°C	SEE IOM FORM K1466 FOR ELECTRICAL RATINGS.
		UL CERTIFICATION NAMEPLATE P/N: 24617BAMM	SEE IOM FORM K1466 FOR ELECTRICAL RATINGS.
		ATEX CERTIFICATION NAMEPLATE P/N: 24617BAMM	SEE IOM FORM K1466 FOR ELECTRICAL RATINGS.
		IEC CERTIFICATION NAMEPLATE P/N: 24617BAMM	SEE IOM FORM K1466 FOR ELECTRICAL RATINGS.
M20 CLEARANCE HOLE		MANUFACTURER NAMEPLATE P/N: 24781AAAM	SEE IOM FORM K1466 FOR ELECTRICAL RATINGS.
EXTERNAL GROUND/EARTH PROVISION		MANUFACTURER NAMEPLATE INTERIOR LEFT OF BOX	SEE IOM FORM K1466 FOR ELECTRICAL RATINGS.

CERTIFICATION NAME PLATES

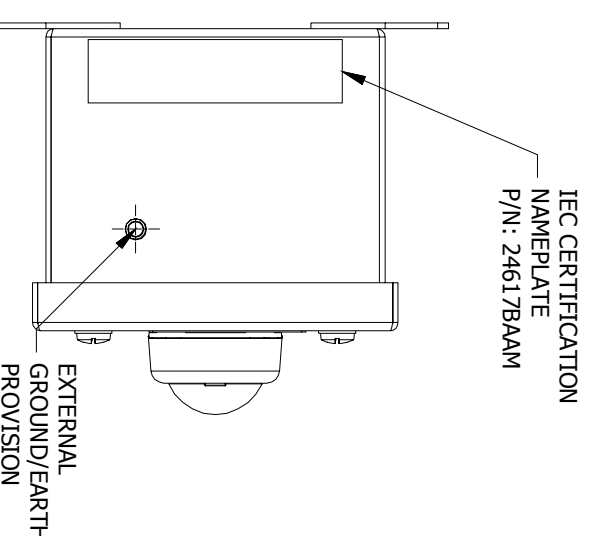

LEFT SIDE VIEW

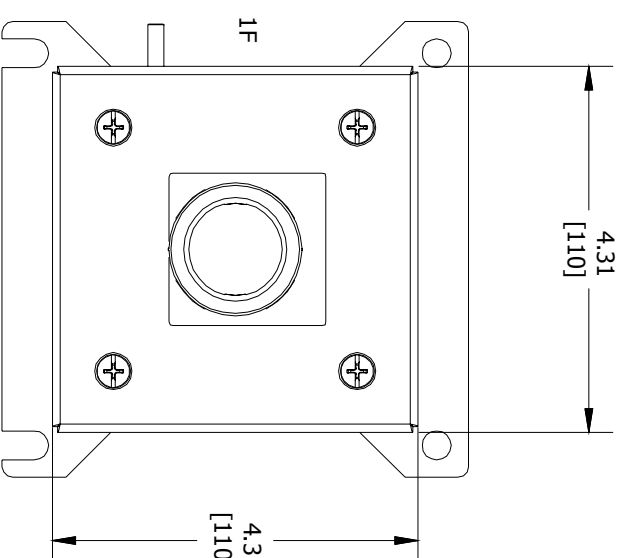

FRONT VIEW

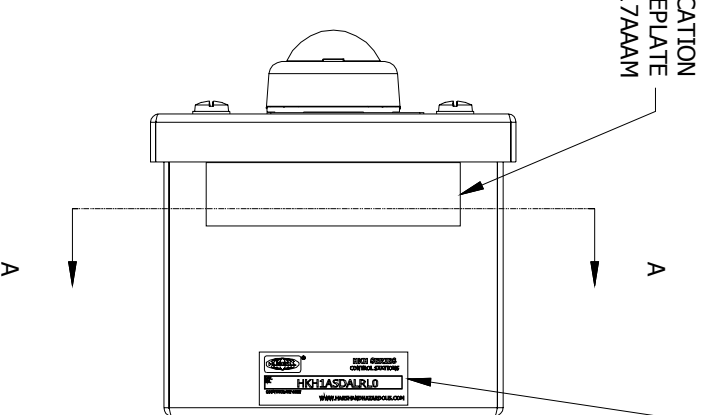

RIGHT SIDE VIEW

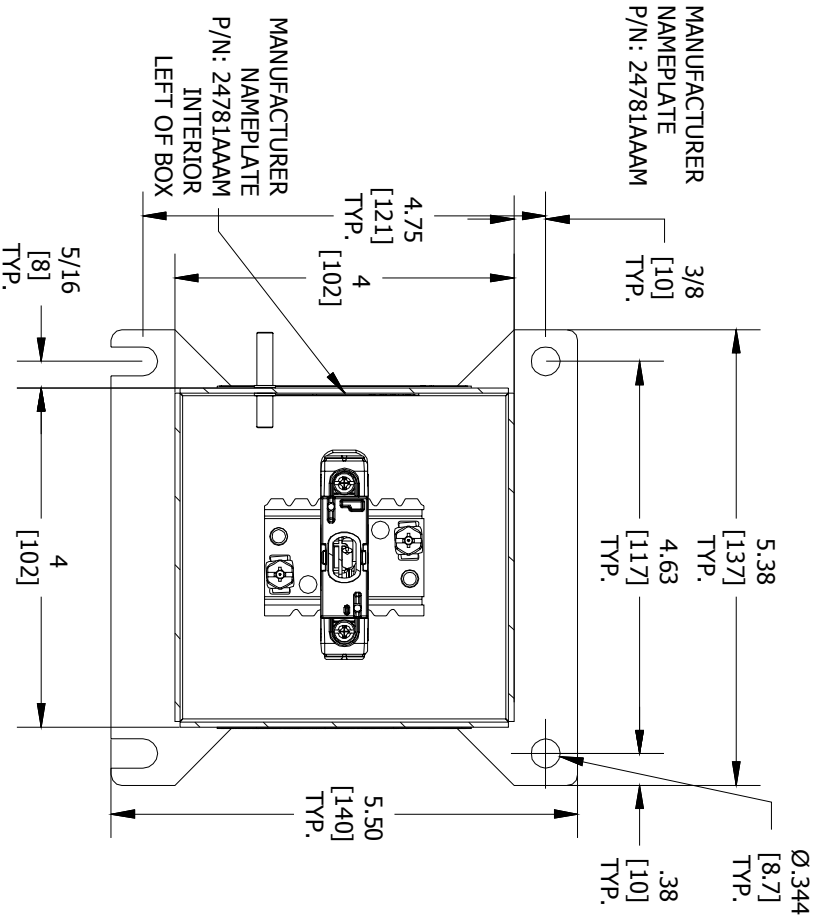

SECTION A-A VIEW

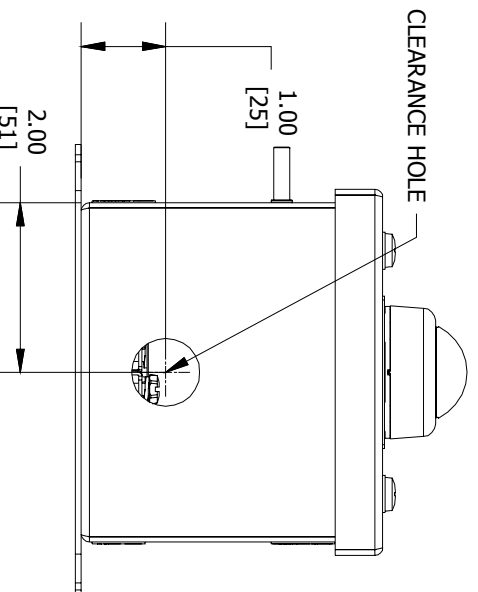

BOTTOM VIEW

COMMENT:

SGN:

DATE:

ACCEPTANCE:

DRAWN BY:

DATE:

DWG NUMBER:

ITEM:

CODE 1: APPROVED (NO COMMENTS)

CODE 2: APPROVED FOR MANUFACTURING

CODE 3: NOT APPROVED RE-SUBMIT

CODE 4: FOR INFORMATION ONLY

PR

09-27-2016

SALES/QUOTE NO.:

N/A

WITH COMMENTS TO BE INCORPORATED

TITLE:

HKH MODIFIED ENCLOSURE (HKHIASDALRLO)

ENTRY NO. HUB/GLAND: NONE

ENTRY 1 NONE

ENTRY NO. HUB/GLAND: NONE

ENTRY 1 NONE

ENTRY NO. HUB/GLAND: NONE

HKH SERIES
CONTROL STATIONS

CAT. NO. **HKHIASDALRLO**

COUNTY/DATE CODE

www.harschandhazardous.com

MFG. NAME PLATE (REF.)

REVISION



KILLARK

THIS DOCUMENT IS THE PROPERTY OF HUBBELL - KILLARK. IT IS LOANED TO YOU AND MUST NOT BE USED IN ANY WAY DETRIMENTAL TO THE INTEREST HUBBELL - KILLARK.

HKH MODIFIED ENCLOSURE (HKHIASDALRLO)

REVISION



KILLARK

SHEET 1 OF 1

A

B

C

D

A

B

C

D