

4

3

2

1

ENCLOSURE INFORMATION	
P/N:	DESCRIPTION:
23198KBAM	BOX PLASTIC 1C, M20 BOTTOM
2319SCAAB	COVER PLASTIC HKH 1C, THREE DEVICE
HKHMBRKT	HKH PANEL MOUNT BRACKET, C. B. & P. L. (3 PL.)

CONTACT BLOCK RATINGS:
690 VAC, 20A, 50-60
60 VDC, 5A, 110VDC, 1.5A

1/2 HP @ 120 VAC, 1 HP @ 208/240/277VAC
NEMA A600/P600 - PILOT DUTY
350VAC, 20A - TUNGSTEN
AC690V, 16A AC-12
AC230V, 16A AC-15
50-60HZ
DC60V, 5A, DC-13
TERMINALS RATED FOR 1-2 CONDUCTORS
#22-10 AWG. (0.5-4mm²)

PILOT LIGHT RATINGS:
LIGHT EMITTING DIODE
12-254 VAC/VDC LED
0.6W/TERMINALS RATED FOR 1-2 CONDUCTORS
#22-10 AWG. (0.5-4mm²)

DEVICE 1 ASSEMBLY (1F)	
P/N:	DESCRIPTION:
HKHPLR	PILOT LIGHT RED LENS ASSEMBLY
LEGEND PLATE:	LAM, BLANK
LOCKOUT DEV.:	N/A
CONTACT 1:	PILOT LIGHT MOD, PM

DEVICE 2 ASSEMBLY (2F)	
P/N:	DESCRIPTION:
HKHBMSS	PUSH BUTTON, MOM., STOP
LEGEND PLATE:	N/A
LOCKOUT DEV.:	N/A
CONTACT 1:	CONTACT BLCK, FACT SEALED N.O. PM, 20A
CONTACT 2:	CONTACT BLCK, FACT SEALED N.C. PM, 20A

DEVICE 3 ASSEMBLY (3F)	
P/N:	DESCRIPTION:
HKHBMSS	PUSH BUTTON, MOM., START
LEGEND PLATE:	N/A
LOCKOUT DEV.:	N/A
CONTACT 1:	CONTACT BLCK, FACT SEALED N.O. PM, 20A
CONTACT 2:	CONTACT BLCK, FACT SEALED N.C. PM, 20A

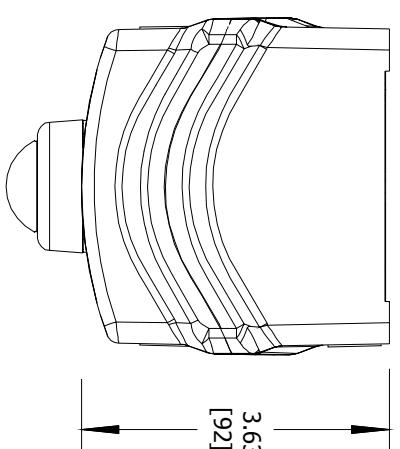

TOP VIEW

	CAT. NO.	HKHMOD Series	DATE CODE S/N
Harsh & Hazardous	www.HARSHANDHAZARDOUS.COM	ST. LOUIS, MO 63113	
	0539 Ex de IIC T6...T4 Gp 0539 Ex de IIC T6...T4 Gp DEMKO 15 ATEX 1405X	SEE IOM FORM K1466 & K1470 FOR T-CODES AND FOR ELECTRICAL RATINGS.	
	Ex de IIC T6...T4 Gp Ex de IIC T6...T4 Gp IECEx UL 15.0054X -50°C ≤T _{amb} +60°C (-40°C ≤T _{amb} +55°C WITH AMMETER)	FOR ELECTRICAL RATINGS, SEE IOM FORM K1466 FOR ELECTRICAL RATINGS.	
	INDUSTRIAL CONTROL EQUIPMENT FOR USE IN ZONE CLASSIFIED HAZ. LOCs. CLASS I, ZONE 1, AEX de IIC T6...T4 Gp; Ex de IIC T6...T4 Gp ZONE 21, AEX tb IIIC T85°C...T135°C Db IP66; Ex tb IIIC T85°C...T135°C Db IP66 CLASS I, DIV. 2, GRP5, A,B,C,D; CLASS II, DIV. 1, GRP5; E,F,G (CANADA ONLY) CLASS II, DIV. 2, GROUPS E,F,G; CLASS III CLASS III, TYPE 3/4/4X/12/13; -50°C ≤T _{amb} +60°C	SEE IOM FORM K1466 FOR ELECTRICAL RATINGS.	

CERTIFICATION NAME PLATES

DEVICE 1 ASSEMBLY (1F)	
P/N:	DESCRIPTION:
HKHBMSS	PUSH BUTTON, MOM., STOP
LEGEND PLATE:	N/A
LOCKOUT DEV.:	N/A
CONTACT 1:	CONTACT BLCK, FACT SEALED N.O. PM, 20A
CONTACT 2:	CONTACT BLCK, FACT SEALED N.C. PM, 20A

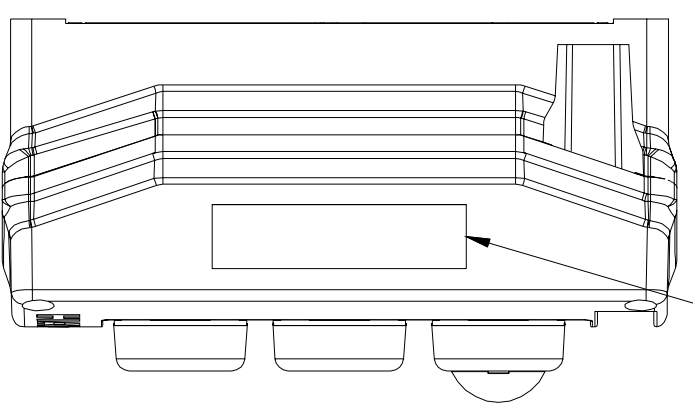

LEFT SIDE VIEW

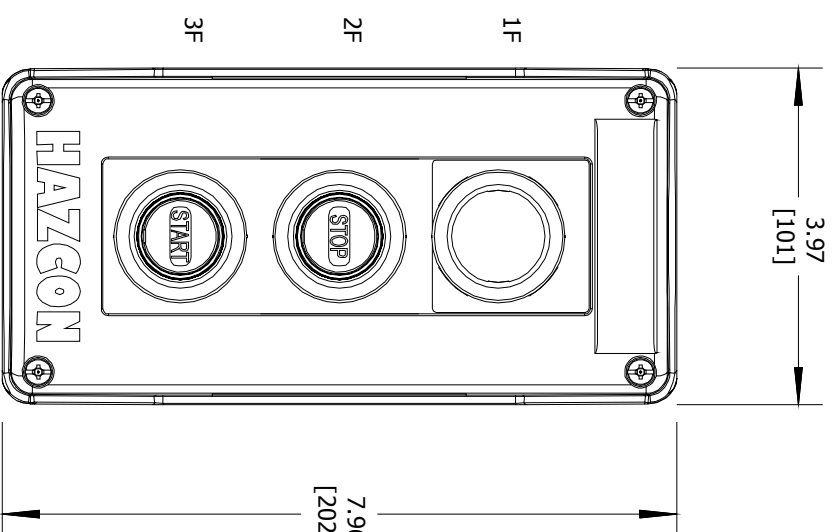

FRONT VIEW

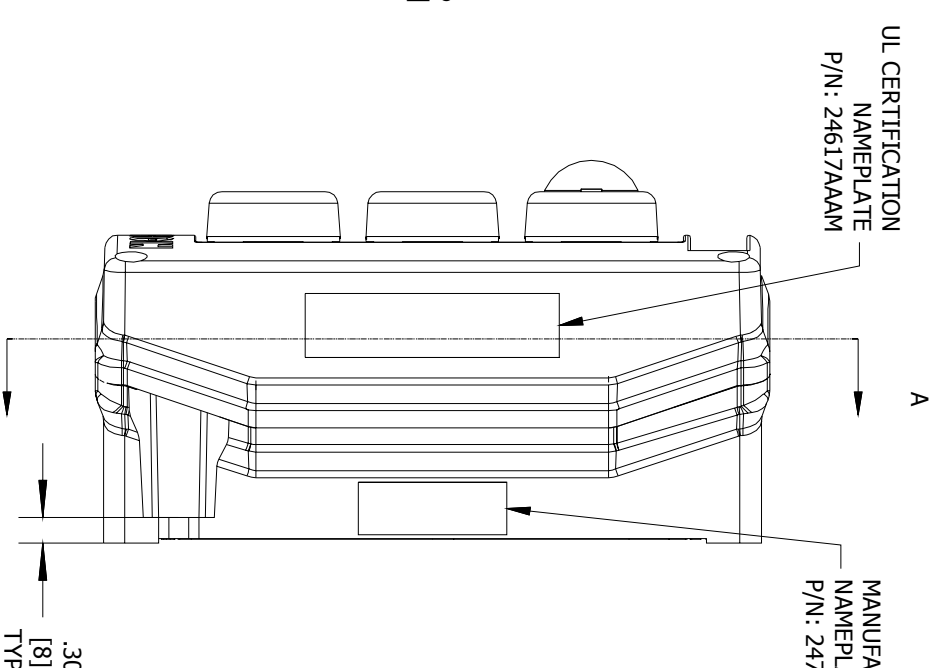

RIGHT SIDE VIEW

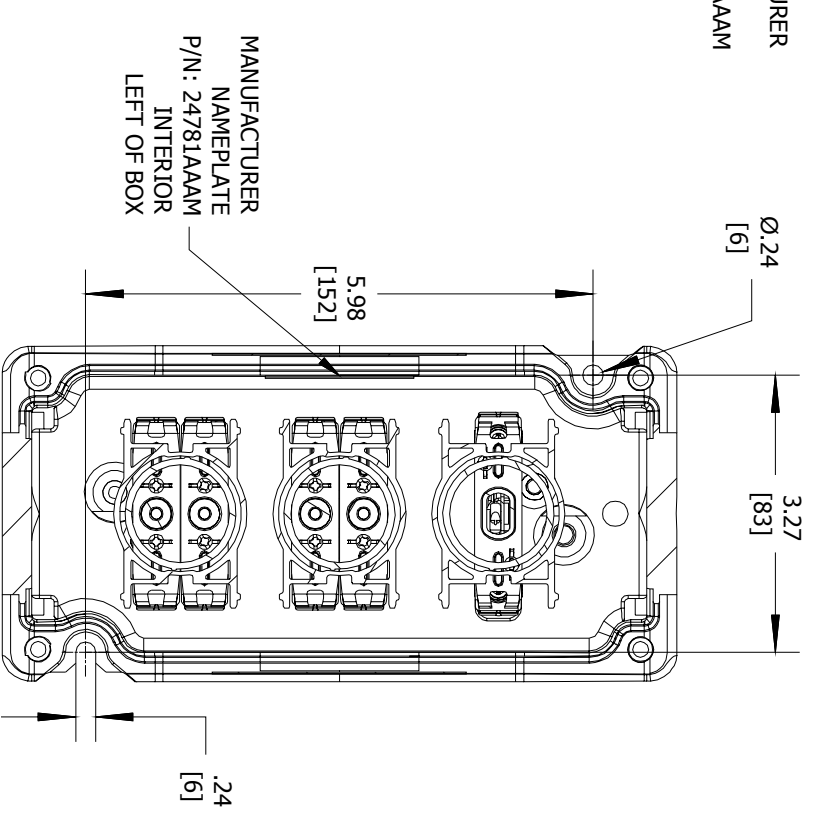

SECTION A-A VIEW

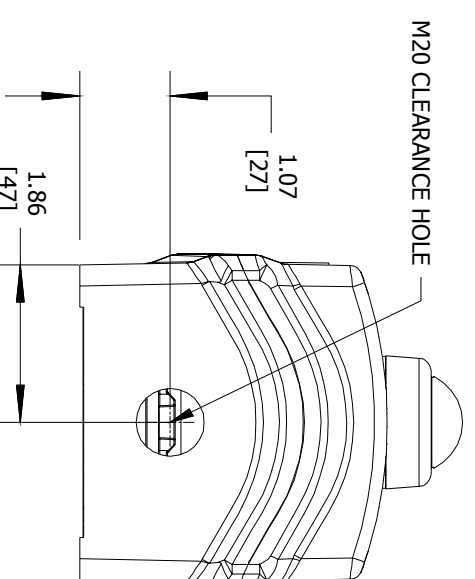

BOTTOM VIEW

COMMENT:

SGN:

DATE:

ACCEPTANCE:

DRAWN BY:

DATE:

DWG NUMBER:

ENTRY NO. HUB/GLAND:

A

COMMENT:

SGN:

DATE:

ACCEPTANCE:

DRAWN BY:

DATE:

DWG NUMBER:

ENTRY NO. HUB/GLAND:

A

COMMENT:

SGN:

DATE:

ACCEPTANCE:

DRAWN BY:

DATE:

DWG NUMBER:

ENTRY NO. HUB/GLAND:

A

COMMENT:

SGN:

DATE:

ACCEPTANCE:

DRAWN BY:

DATE:

DWG NUMBER:

ENTRY NO. HUB/GLAND:

A

	HKH SERIES CONTROL STATION
CAT. NO.	HKHMOD000004
COUNTRY/DATE CODE	
www.HARSHANDHAZARDOUS.COM	

A

REVISION



3

CODE 1: APPROVED (NO COMMENTS)
CODE 2: APPROVED FOR MANUFACTURING
WITH COMMENTS TO BE INCORPORATED
CODE 3: NOT APPROVED RE-SUBMIT
CODE 4: FOR INFORMATION ONLY

TITLE:

HKH MODIFIED ENCLOSURE
(HKHMOD000004)

SALES/QUOTE NO.:

SHEET 1 OF 1

4

3

2

1