

M-11920 5

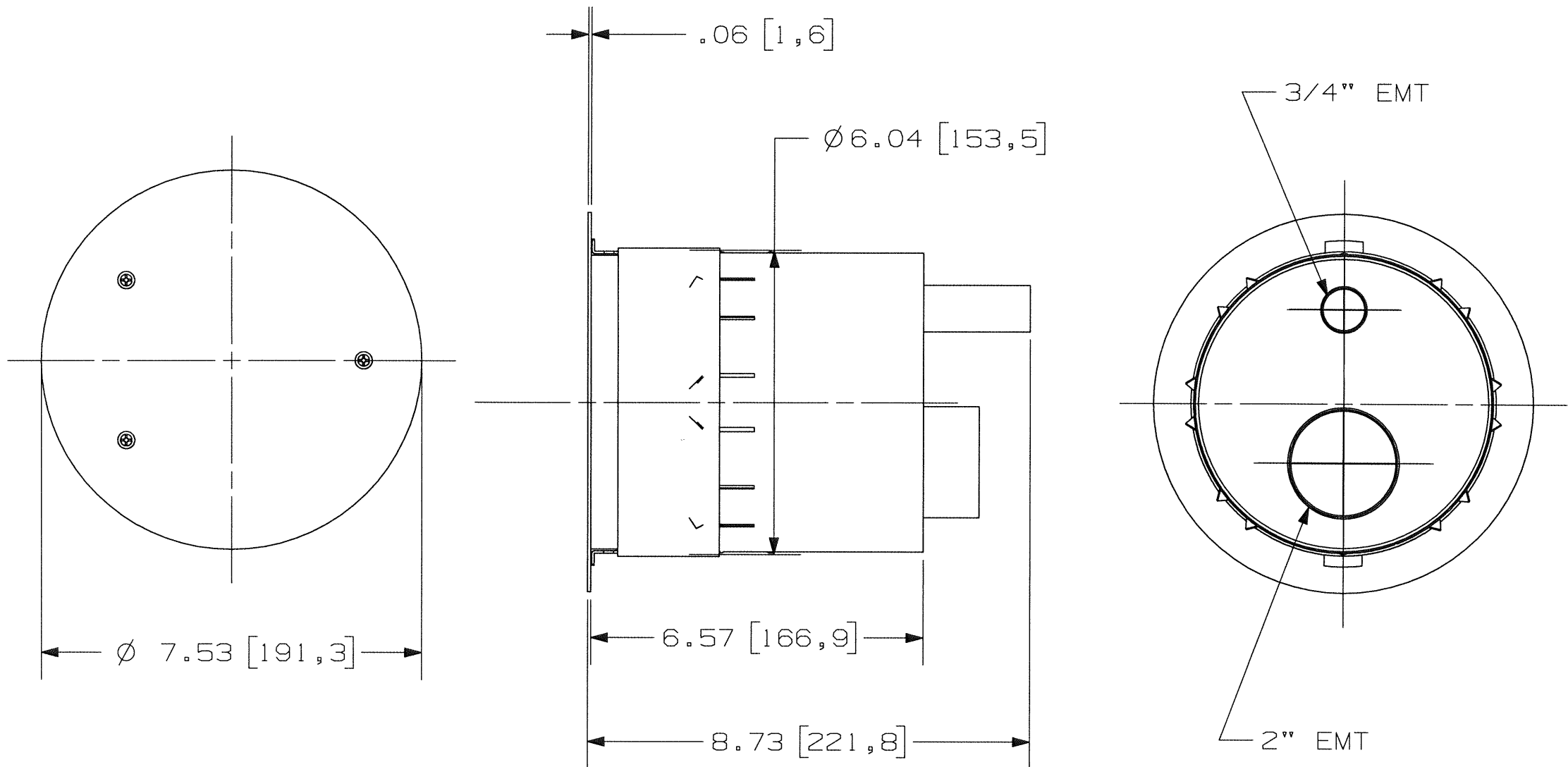

NOTES:  
 1) ALL DIMENSIONS ARE IN INCHES AND [MILLIMETERS]  
 2) JUNCTION BOX S1FRPTJB (NOT SHOWN) IS INCLUDED WITH FLOOR FITTING CATALOG NUMBER S1R6PTFIT. SEE DWG. M-11000 FOR DIMENSIONS OF JUNCTION BOX. JUNCTION BOX SHIPPED LOOSELY WITH UNIT.

LIST OF PARTS

DESCRIPTION	MATERIAL	FINISH
CAN WELDMENT	STEEL	ZINC PLATE
INSTALLATION PLATE	STEEL	ZINC PLATE
SUB-PLATE MTG. PLATE	STEEL	WHITE PAINT
STANDOFFS	STNLS. STEEL	--
FIRE BARRIER, UPPER	FIRE BAR. MATL.	NATURAL
FIRE BARRIER, LOWER	FIRE BAR. MATL.	NATURAL
DIVIDER	STEEL	ZINC PLATE
WASHERS	FIBER	RED
MOUNTING SCREWS	STEEL	ZINC PLATE
SPACER	FIRE BAR. MATL.	BLACK
TAPE	PLASTIC	YELL./BLK

NO.	DESCRIPTION	APP.	DATE
5	ADDED SHEET 2 PER DCN23387	AD	10/18/17
4	IN PARTS LIST- FOR STANDOFF "FINISH" -- WAS ZINC PLATE PER DCN 21112. MYA	PJB	4/8/15
3	UPDATED IMAGES PER DCN20245		12/13/13
2	UPDATED IMAGES, 8.73 WAS 8.71 6.48 WAS 6.45 DCN18755		4/13/12
1	RELEASED PER DCN18435		12/14/11

SYM	REVISIONS	APP	DATE

THE DESIGN AND DIMENSIONS OF THE PRODUCT SHOWN ON THIS DRAWING ARE SUBJECT TO CHANGE WITHOUT NOTICE

TITLE  
 SERVICE FITTING,  
 FIRE RATED POKE THROUGH,  
 6 INCH DIAMETER

TOLERANCES UNLESS OTHERWISE SPECIFIED .XX = ± .01 .XXX = ± .005 ANGLES = ± 2°	WIRING DEVICE-KELLEMS HUBBELL INCORPORATED SHELTON, CT	
	DR. BY SRE	APP. BY
	TR. BY	SCALE 1:2
	CHK. BY	DATE 6/9/11

DIMENSION SHEET FOR CAT. NO. S1R6PTFIT

REPAIRABLE  NON-REPAIRABLE

B

M-11920

5

M-11920 5

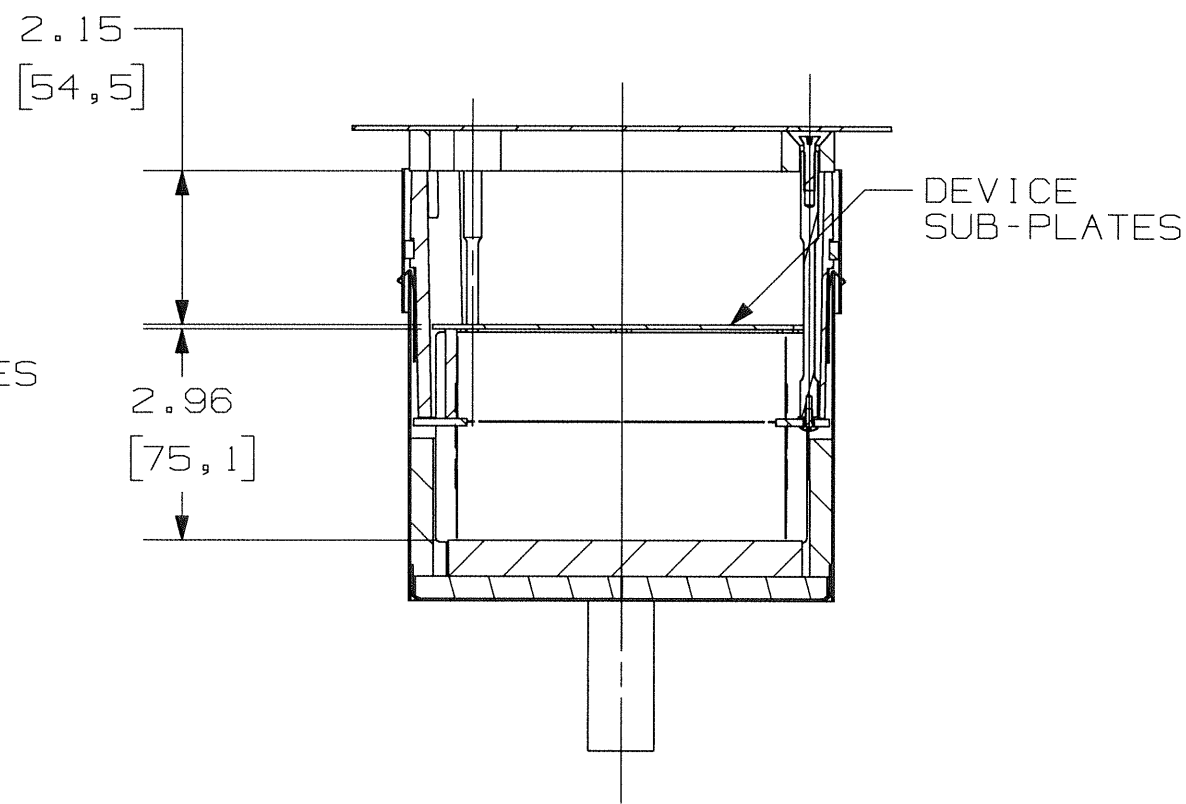
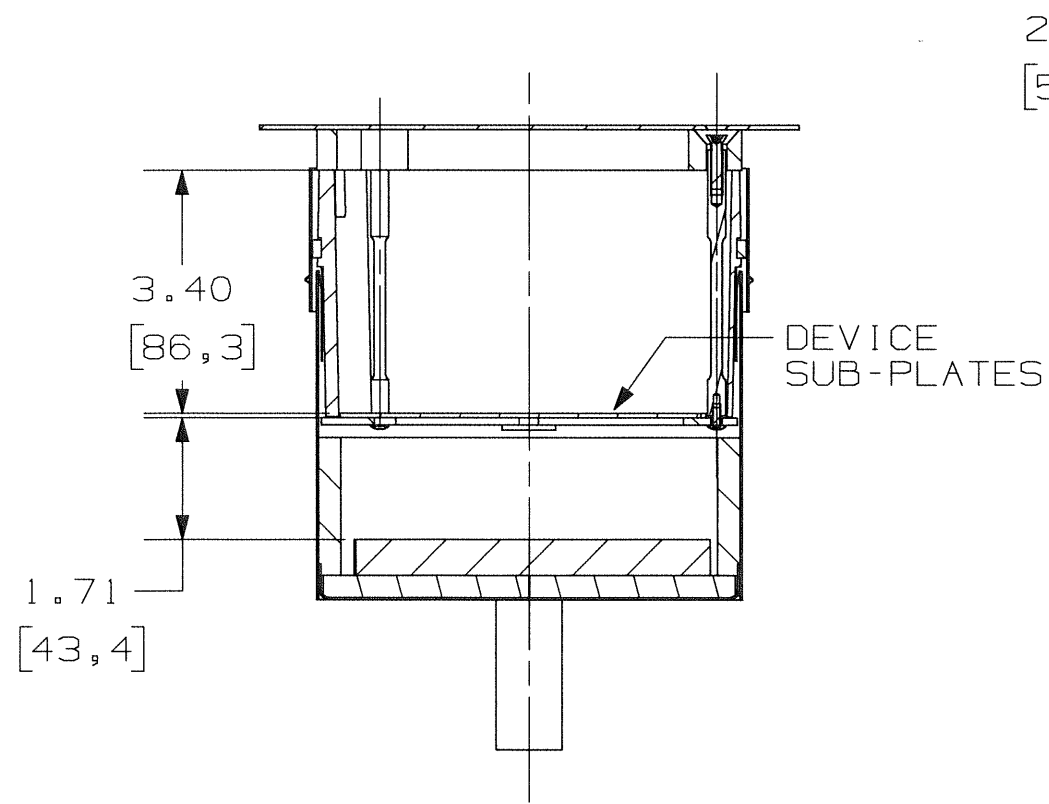
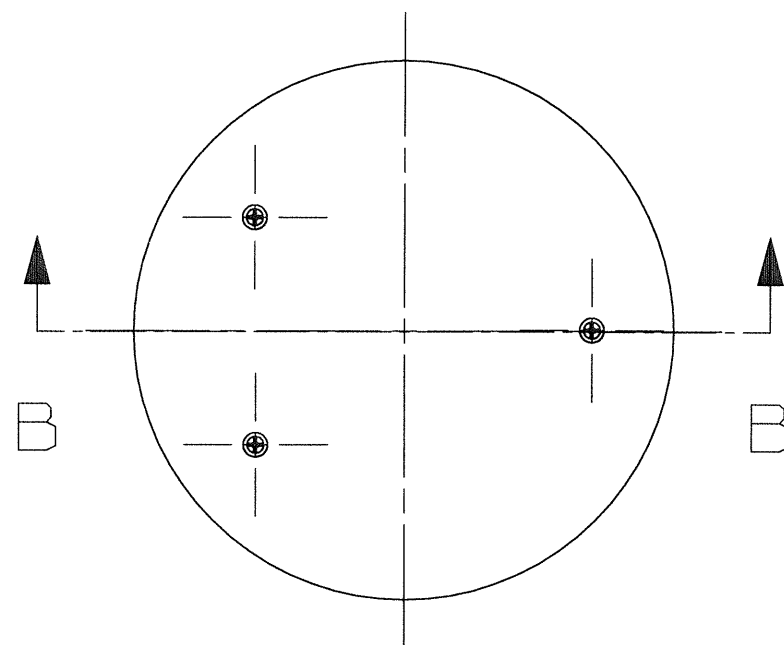
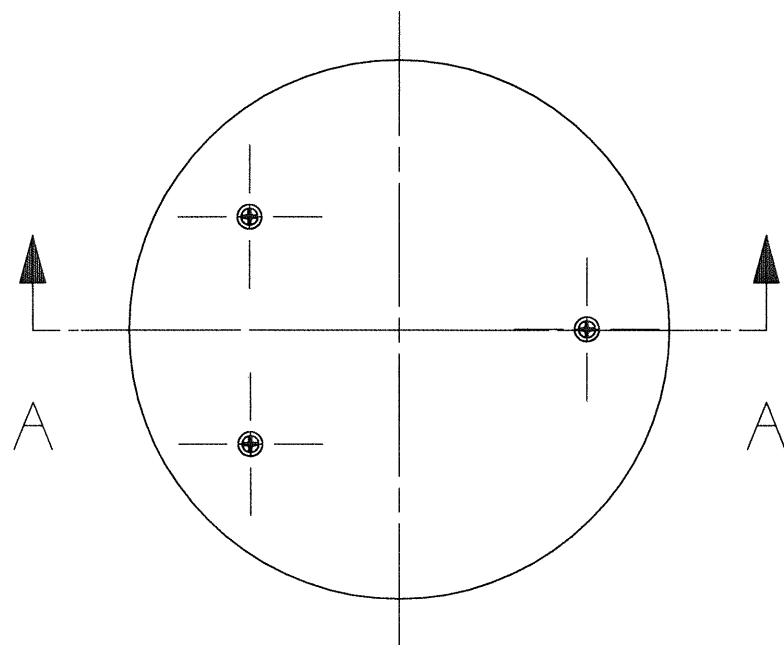

SECTION A-A

SECTION B-B

INCLUDES SIR6SPEXT EXTENSION KIT

LIST OF PARTS		
DESCRIPTION	MATERIAL	FINISH

SYMBOL	REVISIONS	APP.	DATE
5	ADDED THIS SHEET PER DCN23387	AD	10/18/17

THE DESIGN AND DIMENSIONS OF THE PRODUCT SHOWN ON THIS DRAWING ARE SUBJECT TO CHANGE WITHOUT NOTICE

TITLE  
SERVICE FITTING,  
FIRE RATED POKE THROUGH,  
6 INCH DIAMETER

TOLERANCES UNLESS OTHERWISE SPECIFIED .XX = ± .01 .XXX = ± .005 ANGLES = ± 2°	WIRING DEVICE-KELLEMS HUBBELL INCORPORATED SHELTON, CT	
	DR. BY AD	APP. BY
	TR. BY	SCALE 1:2
CHK. BY	DATE 6/9/11	

DIMENSION SHEET FOR CAT. NO. SIR6SPTFIT

REPAIRABLE  NON-REPAIRABLE

B M-11920 5