

M-14179

1

AM/PD PLUG		
CAT NO.	RATING	COLOR
GFPST5266C	15A/120VAC	BLACK
GFPST5266CY	15A/120VAC	YELLOW
GFPST1C	15A/120VAC	YELLOW

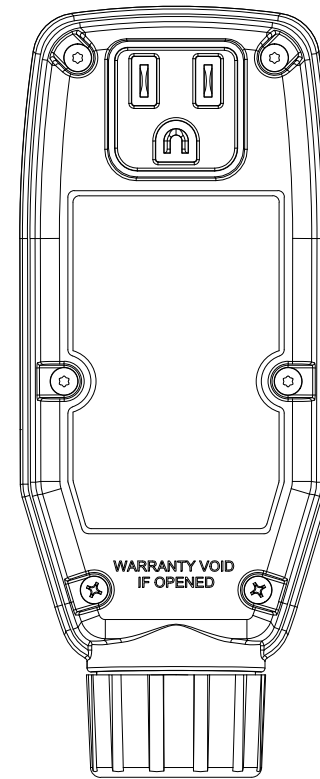
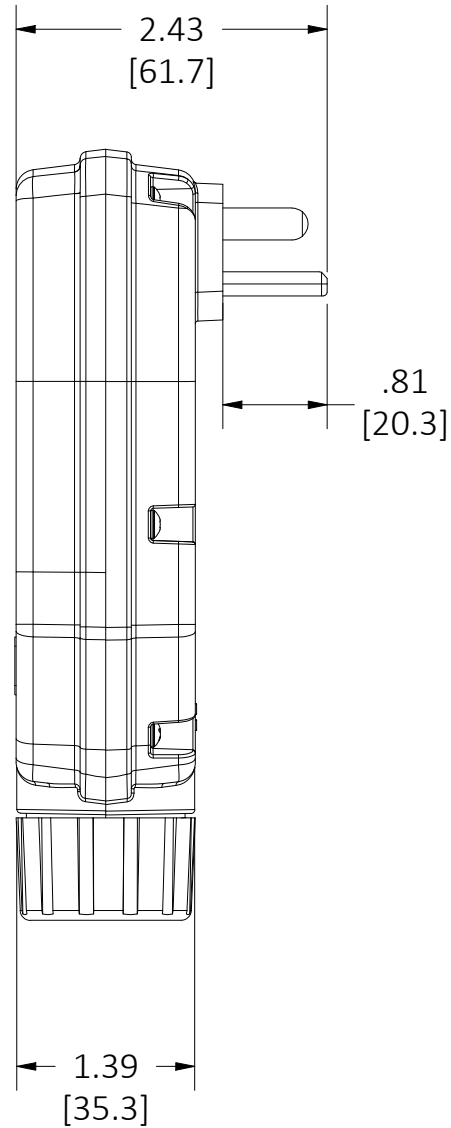
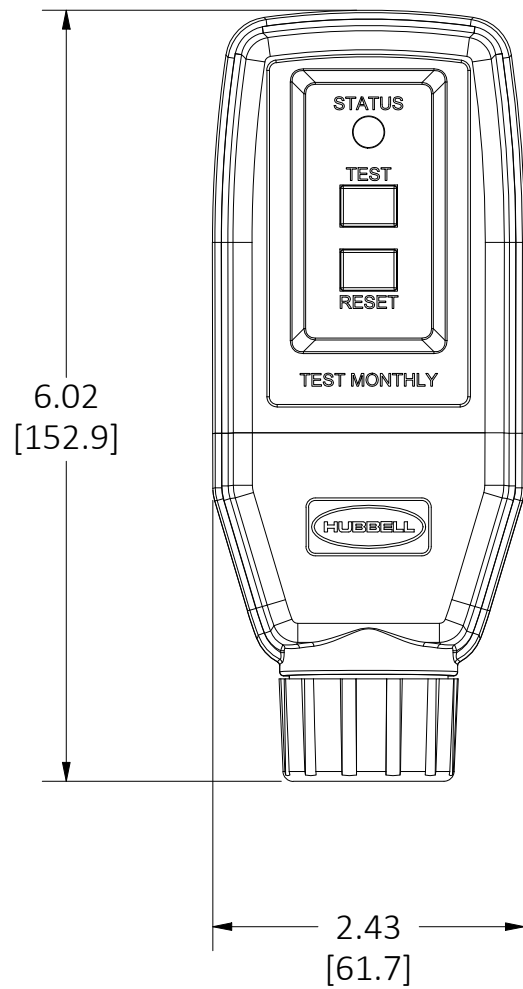

GFPST5266C AND GFPST5266CY

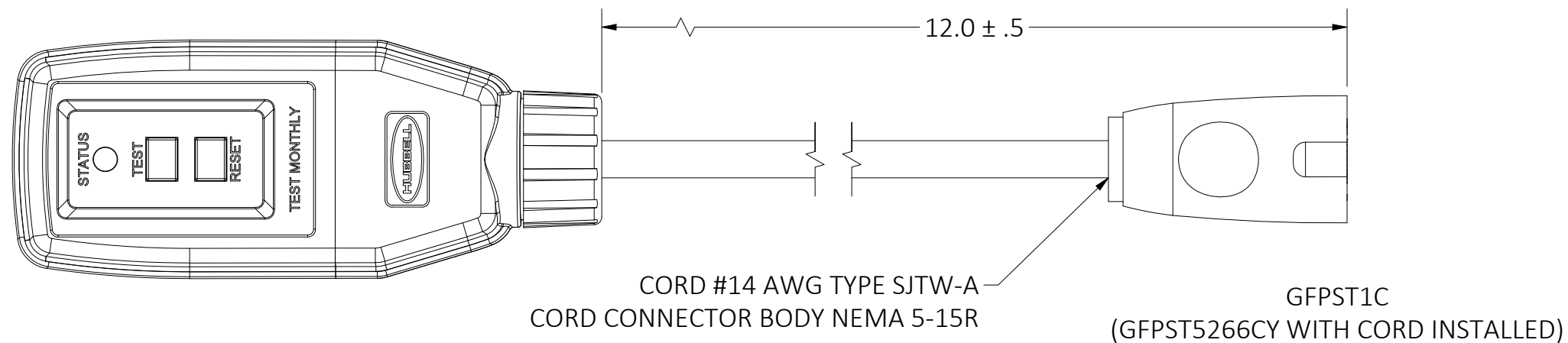

LIST OF PARTS

DESCRIPTION	MATERIAL	FINISH
ENCLOSURE	THERMOPLASTIC	TEXTURED
END CAP	THERMOPLASTIC	TEXTURED
PLUG BLADES & GROUND PIN	BRASS	-
SCREWS	STEEL	ZINC PLATED
BUSHING 3PC SET (NOT SHOWN)	SILICONE RUBBER	-
GOTCHA-RING 3PC SET (NOT SHOWN)	THERMOPLASTIC	-
CORD	THERMOPLASTIC	-

1	INITIAL RELEASE PER EC 220330018643 MV	KP	4/19/22
REV	DESCRIPTION	APP	DATE

THE DESIGN AND DIMENSIONS OF THE PRODUCT SHOWN ON THIS DRAWING ARE SUBJECT TO CHANGE WITHOUT NOTICE. DIMENSIONS ARE IN INCHES [mm].

TITLE  
GFCI AM/PD PLUG



WIRING DEVICE-KELLEMS  
HUBBELL INCORPORATED  
SHELTON, CT

TOLERANCES UNLESS OTHERWISE SPECIFIED .XX = ± .01 .XXX = ± .005 ANGLE TOL. ±2'	DR. BY MV CHK. BY KP	SCALE 2 : 3 DATE 4/19/22
-----------------------------------------------------------------------------------------	-------------------------	-----------------------------

DIMENSION SHEET FOR CAT. NO. SEE TABLE

B

M-14179

1