

M-14331

1

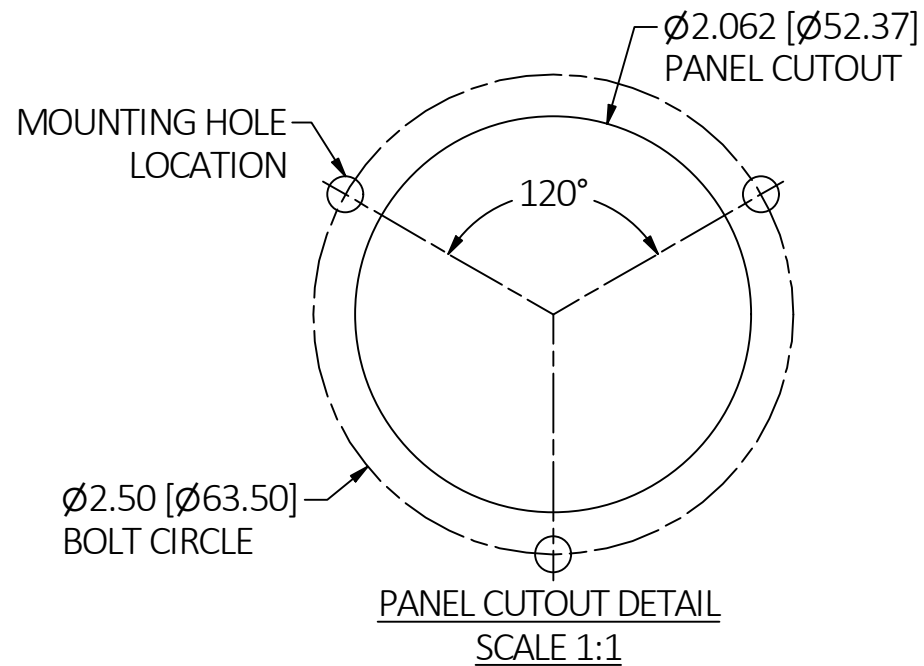

LIST OF PARTS		
DESCRIPTION	MATERIAL	FINISH
CASING	NYLON	NATURAL
CONTACT BODY	NYLON	NATURAL
RETAINER	NYLON	BLACK
CONTACTS	COPPER ALLOY	
SPRING	STAINLESS STEEL	
PLUNGER	NYLON	
ASSEMBLY FASTENERS	STEEL	ZINC PLATE
ISOLATOR	NYLON	BLACK

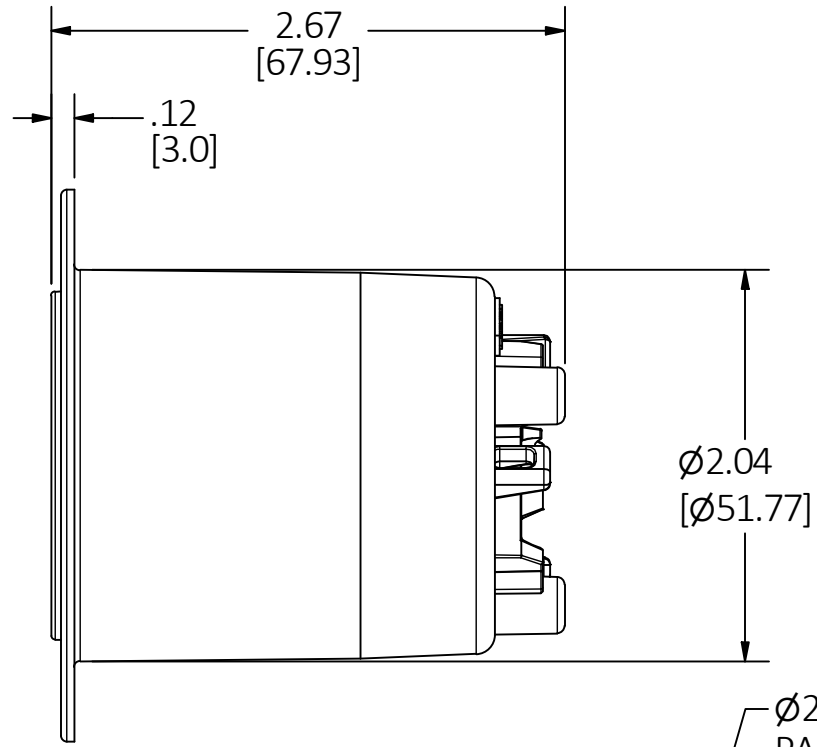
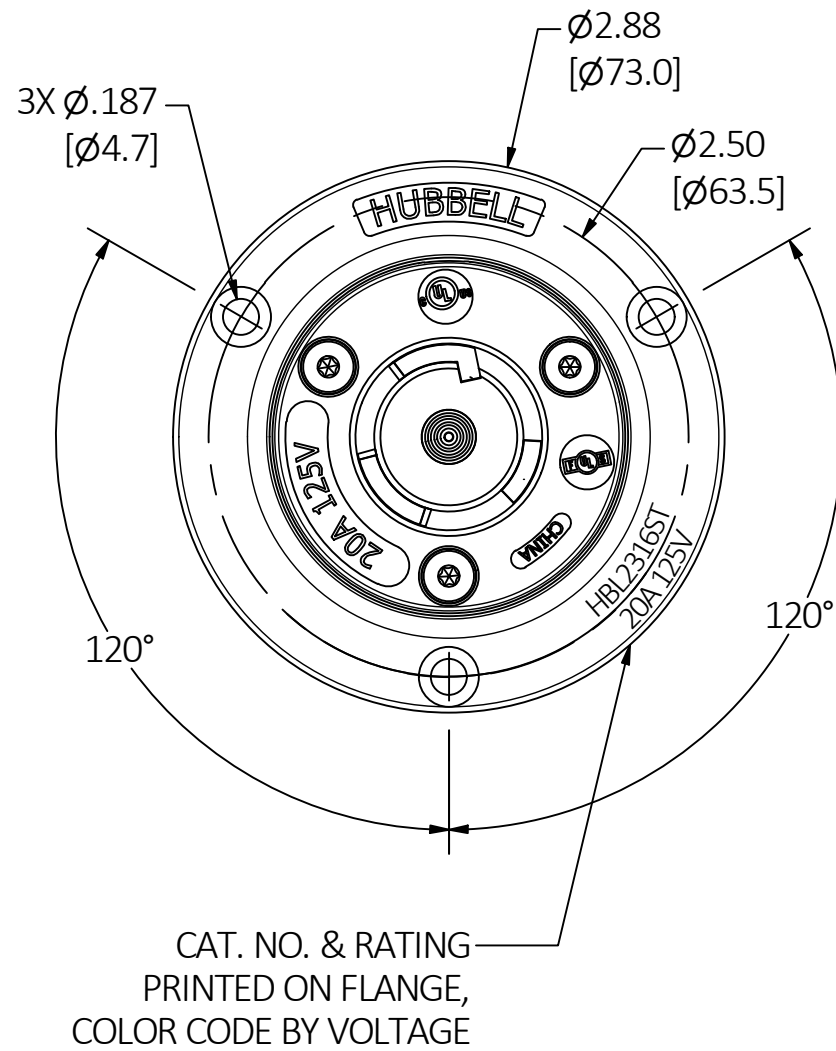
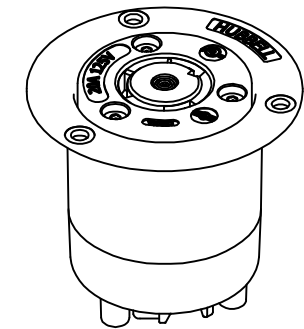

CAT. NO. HBL2316ST  
(NOT SHOWN TO SCALE)

NEMA NO.	RATING	POLE/WIRE	CAT. NO.	CONTACTS CONFIGURATION	VOLTAGE COLOR CODE
L5-20R	125V	2P/3W GROUNDING	HBL2316ST		YELLOW
L6-20R	250V	2P/3W GROUNDING	HBL2326ST		BLUE

NOTES (UNLESS OTHERWISE SPECIFIED):

- DIMENSIONS ARE IN INCHES [mm].
- ALL DEVICES ARE cULus LISTED & FED SPEC.
- WIRING TERMINAL ACCOMMODATION:
  - SOLID WIRE: 14 AWG - 10 AWG COPPER WIRE ONLY
  - STRANDED WIRE (INCLUDING COMPACT STRANDED): 14 AWG - 8 AWG COPPER WIRE ONLY
- CONDUCTOR STRIP LENGTH: 3/4" (19mm)
2. MOUNTING HOLES IN FLANGE ARE SIZED FOR #8 SCREWS.
- MOUNTING SCREWS NOT SUPPLIED.
- CATALOG NUMBERS & RATING ARE PAD PRINTED ON THE FLANGE OF THE DEVICE, COLOR CODED BY VOLTAGE.

1	INITIAL RELEASE PER DCN 220304017679 AM	RGP	2/22/22
REV	DESCRIPTION	APP	DATE

THE DESIGN AND DIMENSIONS OF THE  
PRODUCT SHOWN ON THIS DRAWING ARE  
SUBJECT TO CHANGE WITHOUT NOTICE.  
DIMENSIONS ARE IN INCHES [mm].

TITLE  
3-WIRE SCREWLESS TERMINATION  
FLANGED RECEPTACLE

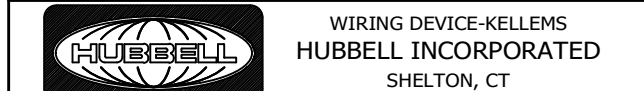

TOLERANCES UNLESS OTHERWISE SPECIFIED .XX = ±.01 .XXX = ±.005 ANGLE TOL. ±2'	DR. BY AM	SCALE 1:1
	CHK. BY RGP	DATE 2/22/22