

M-14705

2

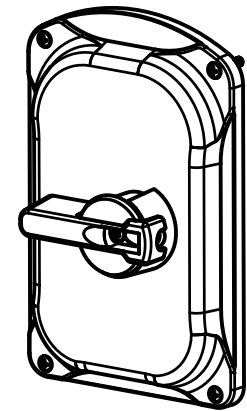
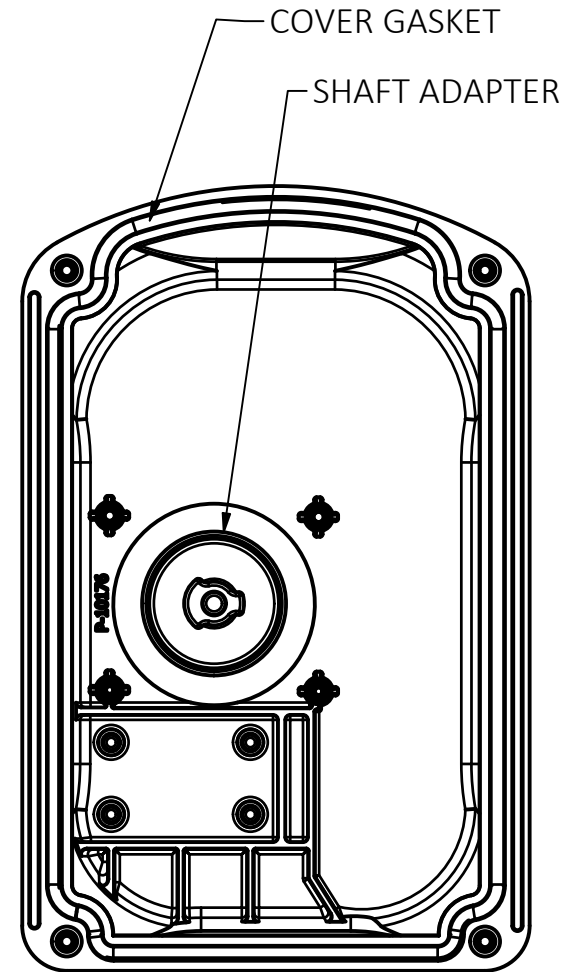
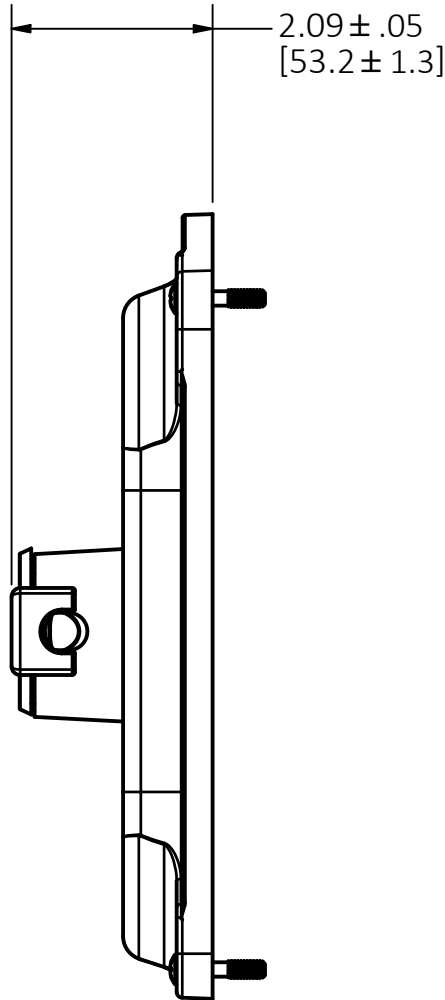
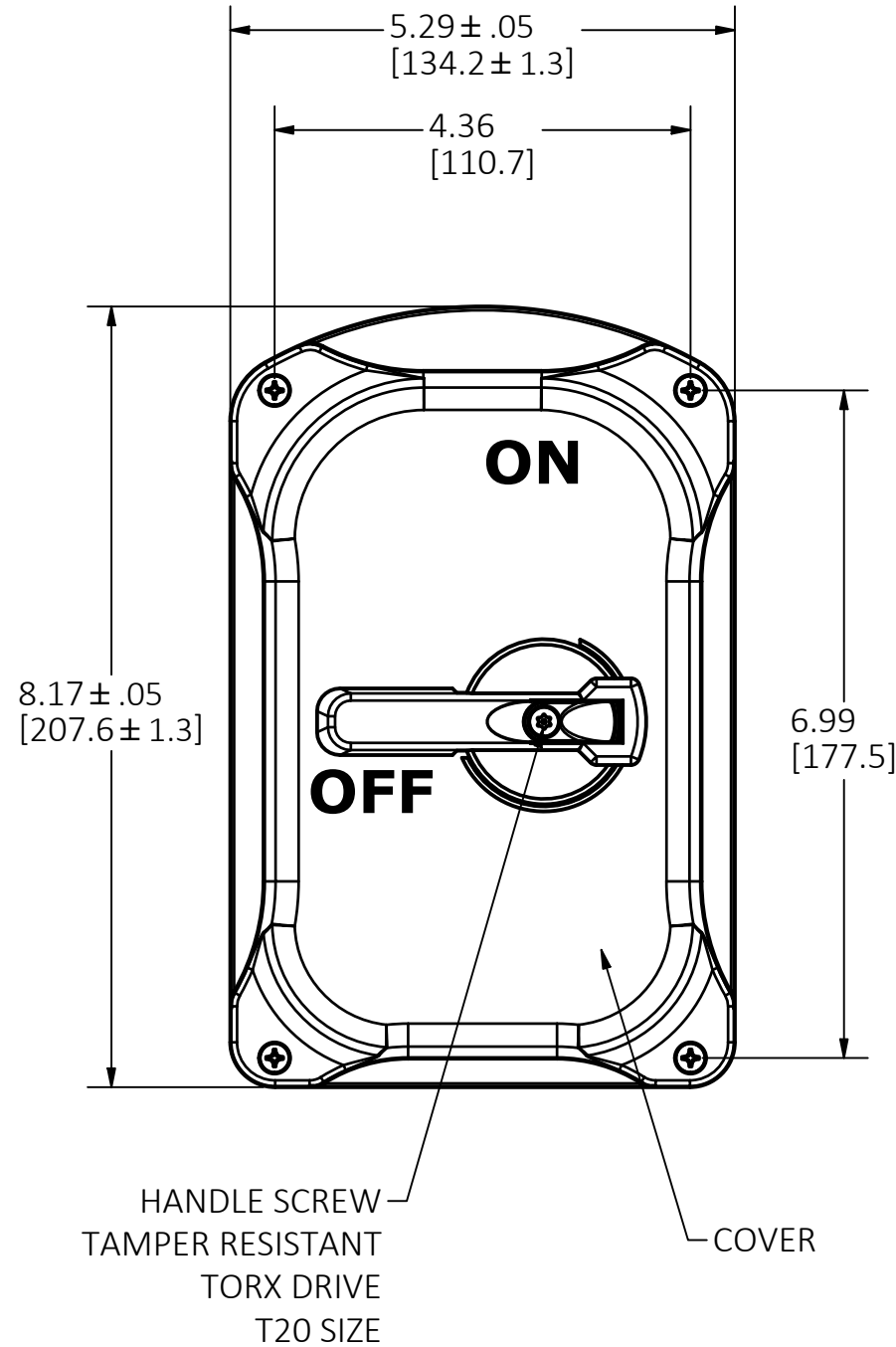

CATALOG NO. HBLDS30RC
(NOT SHOWN TO SCALE)

CATALOG NO.	REPLACEMENT COVER FOR
HBLDS30RC	HBLDS30
HBLDS30TRC	HBLDS30T

DIMENSIONS SHOWN ARE IN INCHES [mm].

LIST OF PARTS

DESCRIPTION	MATERIAL	FINISH
COVER	PBT	
SHAFT ADAPTER	PBT	
HANDLE	PBT	
(4) COVER SCREWS	ST.STEEL	
GASKET COVER	NITRILE RUBBER	

REV	DESCRIPTION	APP	DATE
2	REVISED CAT. NO.'s PER DCN 240326038044 CAC		04/02/24
1	NEW RELEASE PER DCN 230711031802 CAC		07/24/23

THE DESIGN AND DIMENSIONS OF THE
PRODUCT SHOWN ON THIS DRAWING ARE
SUBJECT TO CHANGE WITHOUT NOTICE.
DIMENSIONS ARE IN INCHES [mm].

TITLE

CIRCUIT-LOCK™ SLOPED
REPLACEMENT COVER ASSEMBLY



WIRING DEVICE-KELLEMS
HUBBELL INCORPORATED
SHELTON, CT

TOLERANCES UNLESS OTHERWISE SPECIFIED .XX = ± .01 .XXX = ± .005 ANGLE TOL. ±2'	DR. BY CAC	SCALE 1 / 2
	CHK. BY	DATE 07-24-23

DIMENSION SHEET FOR CAT. NO.
HBLDS30RC, HBLDS30TRC

B

M-14705

2