

M-14807

1

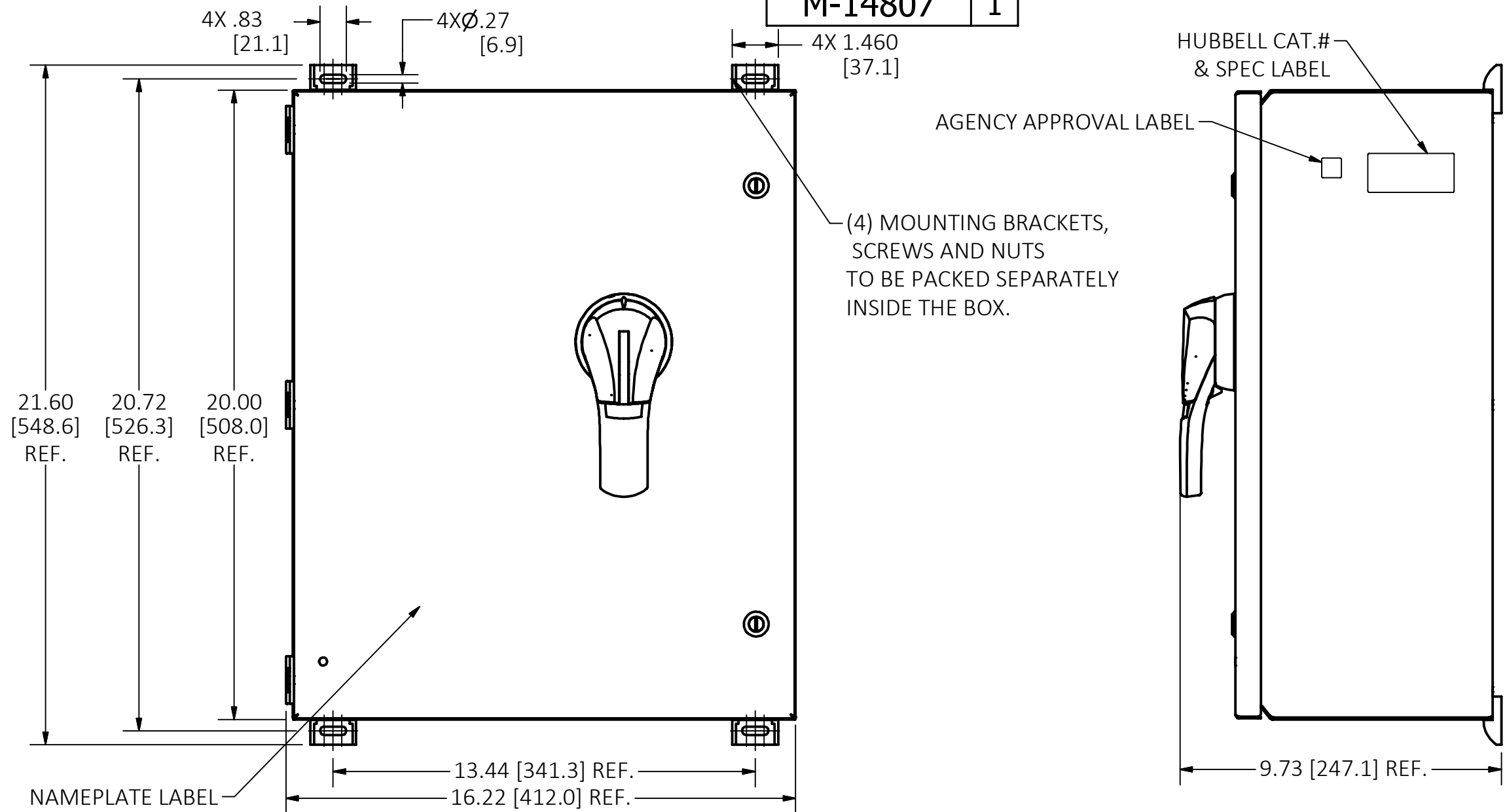

| LIST OF PARTS | | |
|---------------|---------------|----------|
| DESCRIPTION | MATERIAL | FINISH |
| ENCLOSURE | STEEL | |
| HANDLE | THERMOPLASTIC | |
| MOUNTING FEET | THERMOPLASTIC | |
| SCREW | STEEL | Zn PLATE |
| NUT | STEEL | Zn PLATE |
| | | |
| | | |
| | | |
| | | |
| | | |
| | | |
| | | |
| | | |
| | | |

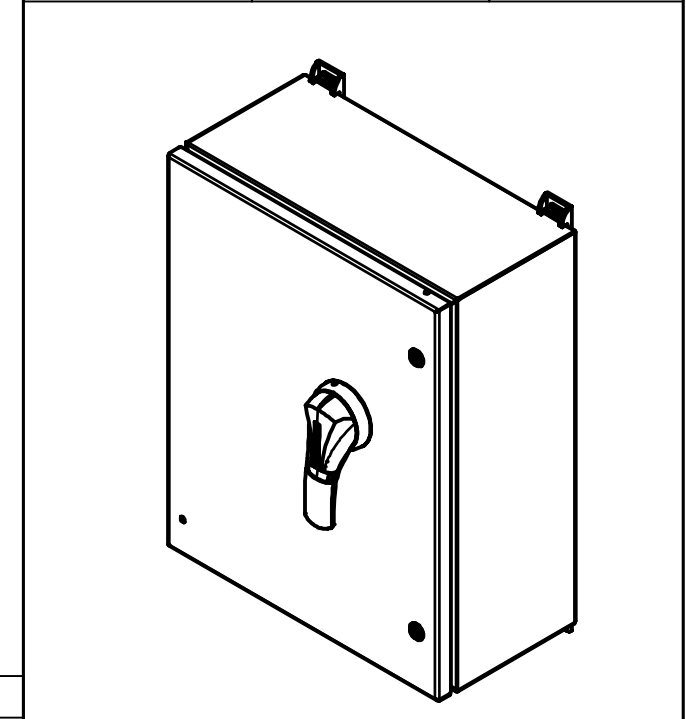

- NOTES:
 1. ALL DIMENSIONS ARE IN INCHES [mm].
 2. SPD TYPE 1, UL LISTED; SPD TYPE 2, c-UL CERTIFICATED.
 3. ENVIRONMENTAL RATING: IP66/NEMA 4.
 4. OPERATING TEMPERATURE: -50/85 °C [-58/185 °F].
 5. SCCR=200KA, I(nom)=20KA.

CAGE CODE 74545

| CAT. No. | DESCRIPTION | WEIGHT /lbs. [kg] | RATED VOLTAGE |
|-------------|---|-------------------|----------------|
| HBL3P150SD | SPD PANEL, 300KA 120/240 VAC, SPLIT PH, W/DISC | 45 [20.4] | 120/240VAC |
| HBL4P150SD | SPD PANEL, 300KA 120/208 VAC, WYE 3PH, W/DISC | 45 [20.4] | 120/208VAC |
| HBL5P150SD | SPD PANEL, 300KA 240 VAC, DELTA 3PH, W/DISC | 45 [20.4] | 240VAC |
| HBL6P150SD | SPD PANEL, 300KA 120/120/240 VAC, DELTA SPLIT 3PH, W/DISC | 45 [20.4] | 120/120/240VAC |
| HBL8P150SD | SPD PANEL, 300KA 277/480 VAC, WYE 3PH, W/DISC | 45 [20.4] | 277/480VAC |
| HBL9P150SD | SPD PANEL, 300KA 480 VAC, DELTA 3PH, W/DISC | 45 [20.4] | 480VAC |
| HBL10P150SD | SPD PANEL, 300KA 347/600 VAC, WYE 3PH, W/DISC | 45 [20.4] | 347/600VAC |
| HBL3P300SD | SPD PANEL, 600KA 120/240 VAC, SPLIT PH, W/DISC | 45 [20.4] | 120/240VAC |
| HBL4P300SD | SPD PANEL, 600KA 120/208 VAC, WYE 3PH, W/DISC | 45 [20.4] | 120/208VAC |
| HBL5P300SD | SPD PANEL, 600KA 240 VAC, DELTA 3PH, W/DISC | 45 [20.4] | 240VAC |
| HBL6P300SD | SPD PANEL, 600KA 120/120/240 VAC, DELTA SPLIT 3PH, W/DISC | 45 [20.4] | 120/120/240VAC |
| HBL8P300SD | SPD PANEL, 600KA 277/480 VAC, WYE 3PH, W/DISC | 45 [20.4] | 277/480VAC |
| HBL9P300SD | SPD PANEL, 600KA 480 VAC, DELTA 3PH, W/DISC | 45 [20.4] | 480VAC |
| HBL10P300SD | SPD PANEL, 600KA 347/600 VAC, WYE 3PH, W/DISC | 45 [20.4] | 347/600VAC |

| 1 | INITIAL RELEASE PER ECN 240626040408 | VS | 07/03/24 |
|-----|---|-----|----------|
| REV | DESCRIPTION | APP | DATE |

THE DESIGN AND DIMENSIONS OF THE PRODUCT SHOWN ON THIS DRAWING ARE SUBJECT TO CHANGE WITHOUT NOTICE. DIMENSIONS ARE IN INCHES [mm].

TITLE
 SPIKESHIELD 150/300SD SERIES AC SURGE PROTECTION PANEL

WIRING DEVICE-KELLEMS
 HUBBELL INCORPORATED
 SHELTON, CT

| | | |
|---|--------------|---------------|
| TOLERANCES UNLESS OTHERWISE SPECIFIED .XX = ±.01 .XXX = ±.005 ANGLE TOL. ±2' | DR. BY VS | SCALE 1 : 4 |
| | CHK. BY D.LI | DATE 07/03/24 |

DIMENSION SHEET FOR CAT. NO. M-14807
SEE TABLE
B
M-14807
1