

BLACK 12/3 SJO CORD
SEE TABLE PER CAT.#
FOR CORD LENGTH.

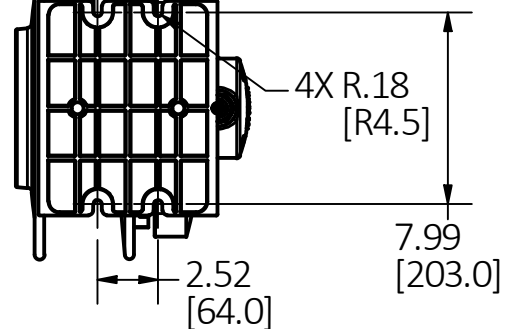

5 FT. LONG BLACK
12/3 SJO CORD

20A PLUG
HBL5366C

NOTES:
1. DIMENSIONS ARE IN INCHES [mm]
EXCEPT CORD LENGTH IN FEET.

M-13987 4

INLINE GFCI MODULE

PORTABLE OUTLET
BOX: HBLPOB1
COLOR: YELLOW

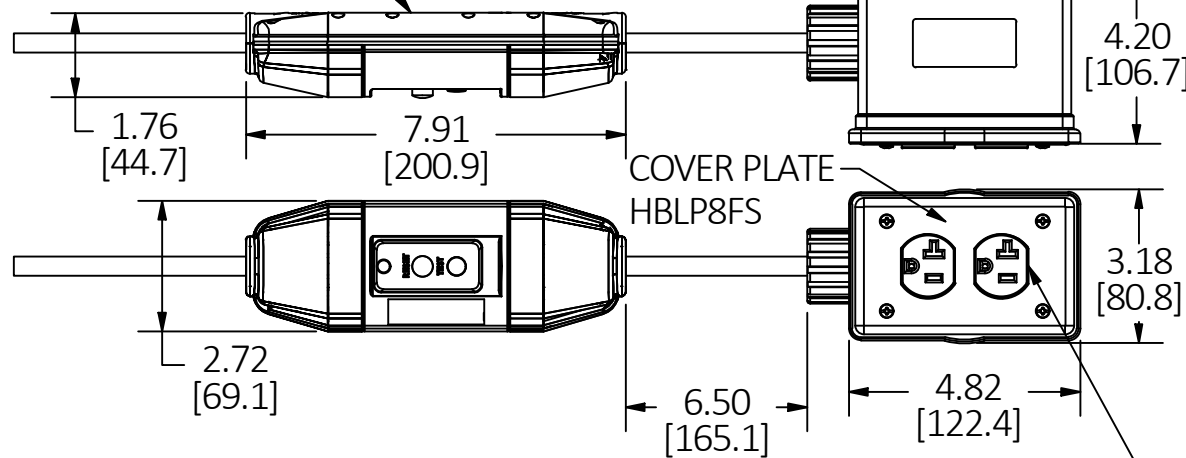

CONFIG. B

PORTABLE OUTLET BOX: HBLPOB1BK
COLOR: BLACK

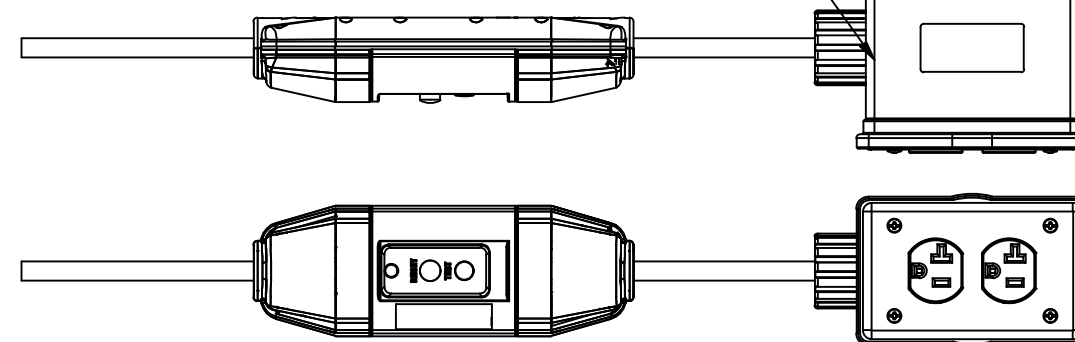

THIS CONFIG IS THE SAME AS CONFIG. B
EXCEPT THE COLOR OF POB AS SHOWN

CONFIG. C

LIST OF PARTS

DESCRIPTION	MATERIAL	FINISH
SPOOL WITH RATCHET	ALUMINIUM	POWDER COATING
SPOOL	ALUMINIUM	POWDER COATING
WIRING CHAMBER COVER	ALUMINIUM	POWDER COATING
SPRING BOX COVER	STEEL	ZINC PLATE
CLOCKWORK SPRING	SPRING STEEL	
GUIDE ARM	ALUMINIUM	POWDER COATING
GUIDE FRAME	THERMOPLASTIC	BLACK
HARDWARE	STEEL	ZINC PLATE
SPINDLE	STEEL	ZINC PLATE
CORD	COPPER	
BALL STOPPER	THERMOPLASTIC	BLACK
INTERNAL TERMINALS	COPPER ALLOY	
FITTING	ALUMINIUM	

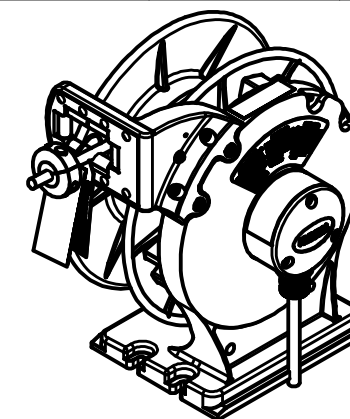

REV	DESCRIPTION	APP	DATE
4	IN ALL VIEWS REPLACED REFERENCE TO 15A WITH 20A AND UPDATED RECEPTACLE VIEWS PER DCN 221114025600 RM	WOV	11/30/22
3	IN CONFIGS A & B: REPLACED LIFT COVER WITH COVER PLATE HBLP8FS AND UPDATED DIM PER DCN 211210015232 RM	WOV	1/25/22
2	ADDED ISO VIEW PER DCN #190321101330. D.LI		4/18/2019
1	NEW RELEASE PER DCN#24214. D.LI		8/7/2018

THE DESIGN AND DIMENSIONS OF THE PRODUCT SHOWN ON THIS DRAWING ARE SUBJECT TO CHANGE WITHOUT NOTICE. DIMENSIONS ARE IN INCHES [mm].

TITLE
REEL WITH PORTABLE OUTLET BOX & 20A DUPLEX RCPT & GFCI MODULE, UL TYPE 1



WIRING DEVICE-KELLEMS
HUBBELL INCORPORATED
SHELTON, CT

TOLERANCES UNLESS OTHERWISE SPECIFIED .XX = ±.01 .XXX = ±.005 ANGLE TOL. ±2°	DR. BY D. LI	SCALE NONE
CHK. BY	DATE 8/6/2018	

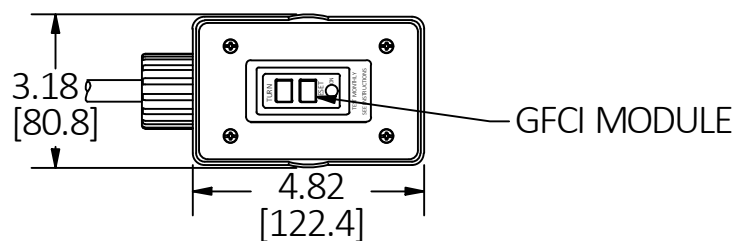

GFCI MODULE

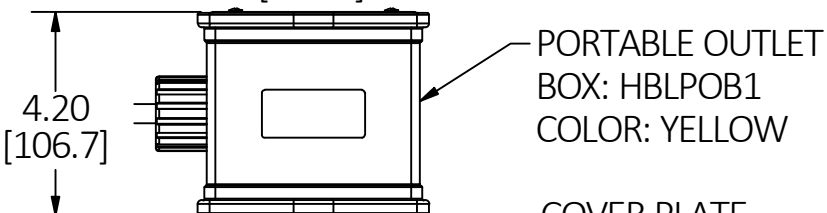

PORTABLE OUTLET
BOX: HBLPOB1
COLOR: YELLOW

COVER PLATE
HBLP8FS

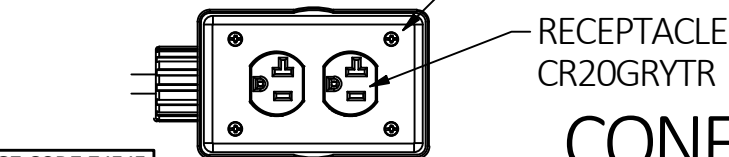

RECEPTACLE
CR20GRYTR

CONFIG. A

CAGE CODE 74545

CATALOG	DESCRIPTION	CONFIG.	RATING	CORD LENGTH	REEL COLOR	APPROX. WEIGHT
HBLI45123GF20	REEL W/GFCI MOD & (1) DPLX, 45'	A	20A 125V	45 FT.	WHITE	26.5 LB [12KG]
HBLI35123GF20	REEL W/GFCI MOD & (1) DPLX, 35'	A	20A 125V	35 FT.	WHITE	24.9 LB [11.3KG]
HBLI25123GF20	REEL W/GFCI MOD & (1) DPLX, 25'	A	20A 125V	25 FT.	WHITE	23.4 LB [10.6KG]
HBLI45123GF220	REEL W/GFCI MOD & (2) DPLX, PLATE COVER 45'	B	20A 125V	45 FT.	WHITE	26.5 LB [12KG]
HBLI35123GF220	REEL W/GFCI MOD & (2) DPLX, PLATE COVER 35'	B	20A 125V	35 FT.	WHITE	24.9 LB [11.3KG]
HBLI25123GF220	REEL W/GFCI MOD & (2) DPLX, PLATE COVER 25'	B	20A 125V	25 FT.	WHITE	23.4 LB [10.6KG]
HBLI45123GF220M1	REEL W/GFCI MOD & (2) DPLX, PLATE COVER 45'	C	20A 125V	45 FT.	WHITE	26.5 LB [12KG]
HBLI35123GF220M1	REEL W/GFCI MOD & (2) DPLX, PLATE COVER 35'	C	20A 125V	35 FT.	WHITE	24.9 LB [11.3KG]
HBLI25123GF220M1	REEL W/GFCI MOD & (2) DPLX, PLATE COVER 25'	C	20A 125V	25 FT.	WHITE	23.4 LB [10.6KG]
HBLI45123GF20Y	YL REEL W/GFCI MOD & (1) DPLX, 45'	A	20A 125V	45 FT.	YELLOW	26.5 LB [12KG]
HBLI35123GF20Y	YL REEL W/GFCI MOD & (1) DPLX, 35'	A	20A 125V	35 FT.	YELLOW	24.9 LB [11.3KG]
HBLI25123GF20Y	YL REEL W/GFCI MOD & (1) DPLX, 25'	A	20A 125V	25 FT.	YELLOW	23.4 LB [10.6KG]
HBLI45123GF220Y	YL REEL W/GFCI MOD & (2) DPLX, PLATE COVER 45'	B	20A 125V	45 FT.	YELLOW	26.5 LB [12KG]
HBLI35123GF220Y	YL REEL W/GFCI MOD & (2) DPLX, PLATE COVER 35'	B	20A 125V	35 FT.	YELLOW	24.9 LB [11.3KG]
HBLI25123GF220Y	YL REEL W/GFCI MOD & (2) DPLX, PLATE COVER 25'	B	20A 125V	25 FT.	YELLOW	23.4 LB [10.6KG]
HBLI45123GF220M1Y	YL REEL W/GFCI MOD & (2) DPLX, PLATE COVER 45'	C	20A 125V	45 FT.	YELLOW	26.5 LB [12KG]
HBLI35123GF220M1Y	YL REEL W/GFCI MOD & (2) DPLX, PLATE COVER 35'	C	20A 125V	35 FT.	YELLOW	24.9 LB [11.3KG]
HBLI25123GF220M1Y	YL REEL W/GFCI MOD & (2) DPLX, PLATE COVER 25'	C	20A 125V	25 FT.	YELLOW	23.4 LB [10.6KG]

DIMENSION SHEET FOR CAT. NO.
SEE TABLE

B

M-13987

4