

M-14072

3

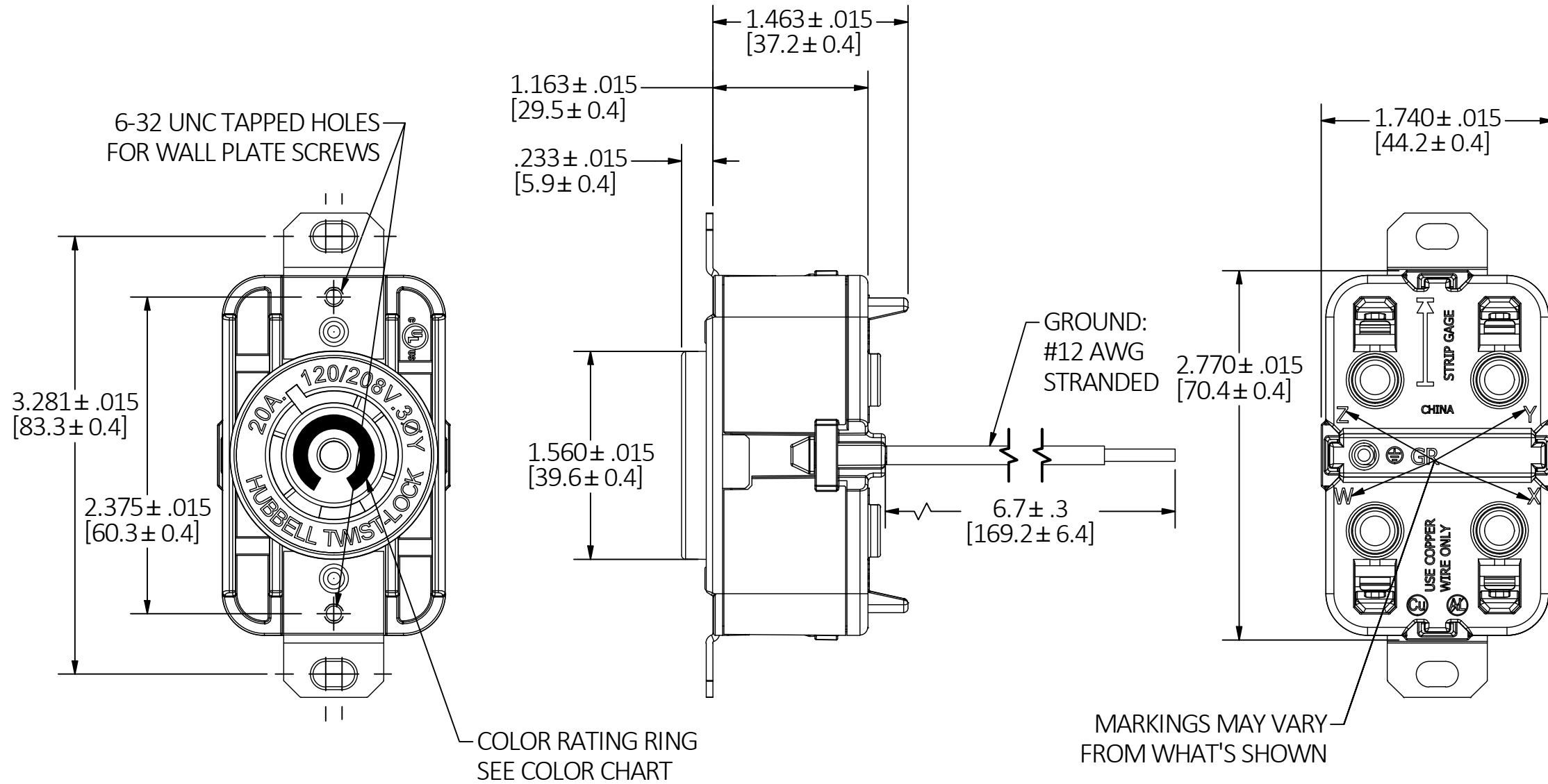

LIST OF PARTS		
DESCRIPTION	MATERIAL	FINISH
COVER	THERMOPLASTIC	
MID HOUSING	THERMOPLASTIC	
BASE	THERMOPLASTIC	
CONTACTS	BRASS	
SPRING	STEEL	
PLUNGER	THERMOPLASTIC	
GR. SHUNT	BRASS	
MOUNTING PLATE	BRASS	
RIVET	BRASS	

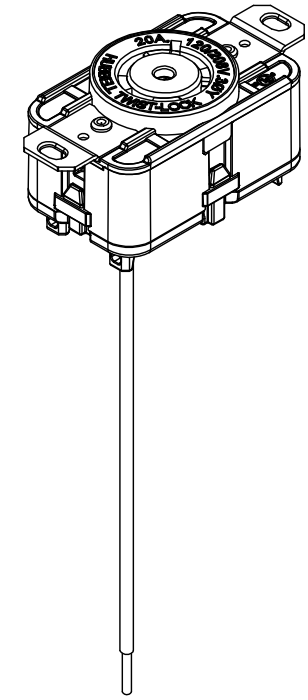

CAT NO.	NEMA NO.	RATING	POLE/WIRE	CONFIGURATION	RATING RING COLOR
HBL2510ST	L21-20	20A 120/208V 3ØY	4P/5W GROUNDING		BLUE
HBL2520ST	L22-20	20A 277/480V 3ØY	4P/5W GROUNDING		RED

- NOTES:
- DIMENSIONS ARE IN INCHES [mm].
  - WIRING TERMINAL ACCOMMODATION:
    - SOLID WIRE: 14 AWG - 10 AWG COPPER WIRE ONLY
    - STRANDED WIRE (INCLUDING COMPACT STRANDED): 14 AWG - 8 AWG COPPER WIRE ONLY
  - CONDUCTOR STRIP LENGTH: 0.600" (15.24mm)

3	LEADED GROUND WIRE LENGTH INCREASED BY 2 INCHES PER DCN 220315017977 AM	RGP	3/11/22
REV	DESCRIPTION	APP	DATE

THE DESIGN AND DIMENSIONS OF THE PRODUCT SHOWN ON THIS DRAWING ARE SUBJECT TO CHANGE WITHOUT NOTICE. DIMENSIONS ARE IN INCHES [mm].

TITLE  
CUST. DWG, 20A 5 WIRE SPRING TERMINATION RECEPTACLE



WIRING DEVICE-KELLEMS  
HUBBELL INCORPORATED  
SHELTON, CT

TOLERANCES UNLESS OTHERWISE SPECIFIED  
.XX = ± .01  
.XXX = ± .005  
ANGLE TOL. ±2'

DR. BY	RGP	SCALE	1 : 1
CHK. BY	TLS	DATE	05/05/19