

M-14073

5

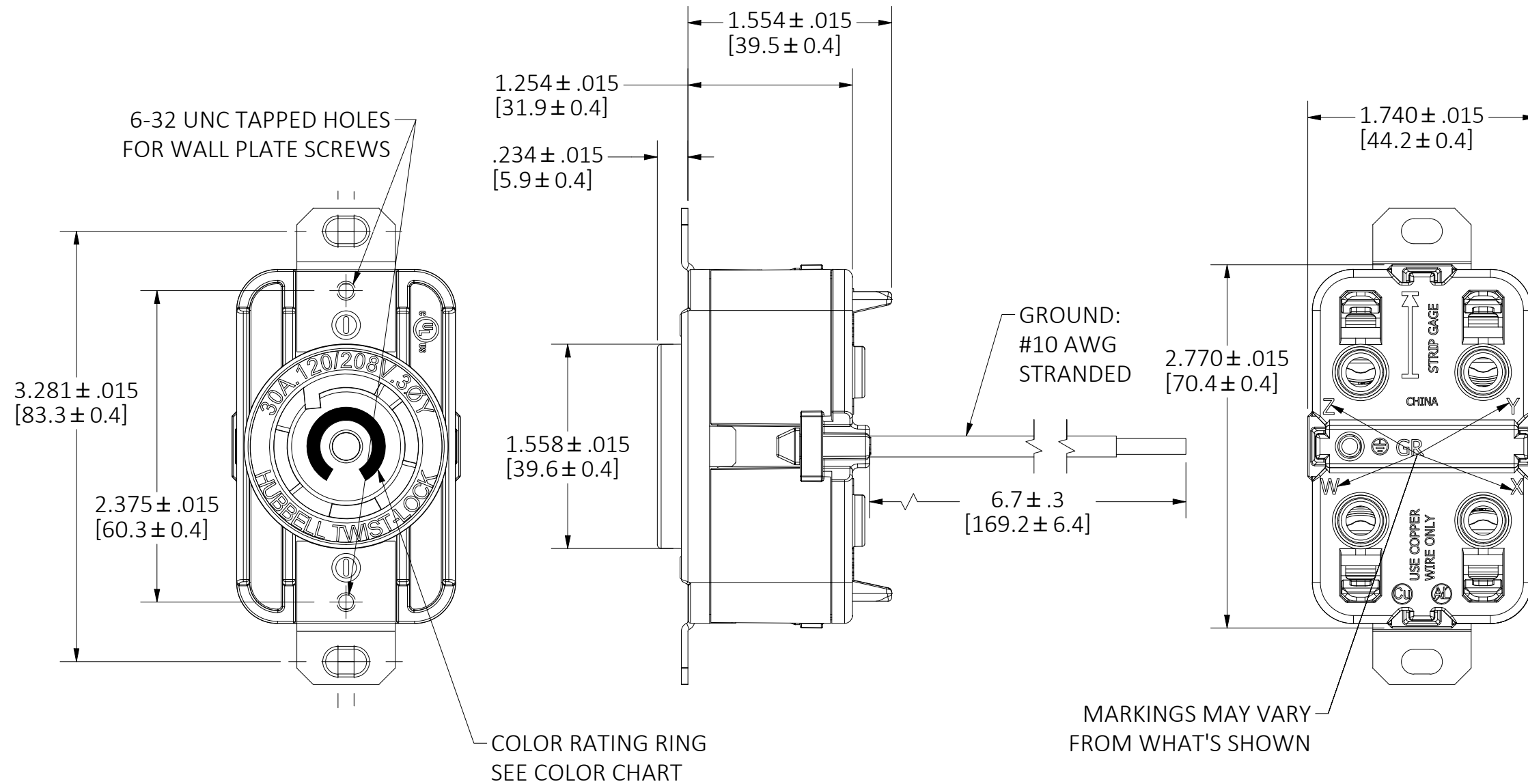

LIST OF PARTS		
DESCRIPTION	MATERIAL	FINISH
COVER	THERMOPLASTIC	
MID HOUSING	THERMOPLASTIC	
BASE	THERMOPLASTIC	
CONTACTS	BRASS	
SPRING	STEEL	
PLUNGER	THERMOPLASTIC	
GR. SHUNT	BRASS	
MOUNTING PLATE	BRASS	
RIVET	BRASS	

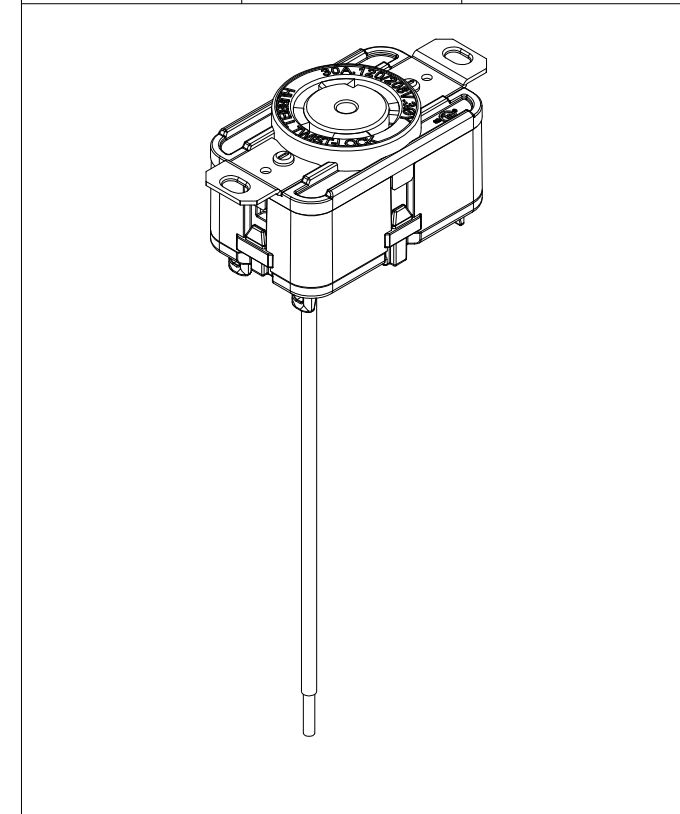

5	UPDATED RIVETS PER DCN 220908023832 RGP	DL	09/07/22
REV	DESCRIPTION	APP	DATE

CAT NO.	NEMA NO.	RATING	POLE/WIRE	CONFIGURATION	RATING RING COLOR
HBL2810ST	L21-30	30A 120/208V 3ØY	4P/5W GROUNDING		BLUE
HBL2820ST	L22-30	30A 277/480V 3ØY	4P/5W GROUNDING		RED

NOTES:

- DIMENSIONS ARE IN INCHES [mm].
- WIRING TERMINAL ACCOMMODATION:
 - SOLID WIRE: 14 AWG - 10 AWG COPPER WIRE ONLY
 - STRANDED WIRE (INCLUDING COMPACT STRANDED): 14 AWG - 8 AWG COPPER WIRE ONLY
- CONDUCTOR STRIP LENGTH: 0.600" (15.24mm)

THE DESIGN AND DIMENSIONS OF THE PRODUCT SHOWN ON THIS DRAWING ARE SUBJECT TO CHANGE WITHOUT NOTICE. DIMENSIONS ARE IN INCHES [mm].

TITLE
CUST. DWG, 30A 5 WIRE SPRING TERMINATION RECEPTACLE



WIRING DEVICE-KELLEMS
HUBBELL INCORPORATED
SHELTON, CT

TOLERANCES UNLESS OTHERWISE SPECIFIED
.XX = ± .01
.XXX = ± .005
ANGLE TOL. ±2'

DR. BY	RGP	SCALE	1 : 1
CHK. BY	TLS	DATE	05/17/19