

M-14075

4

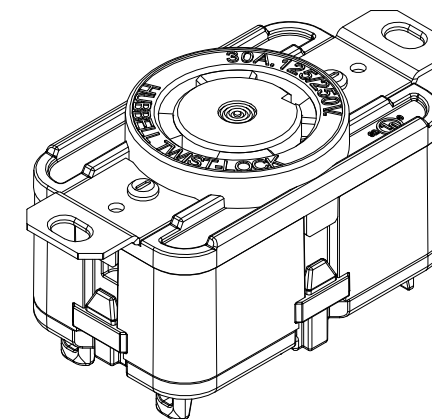
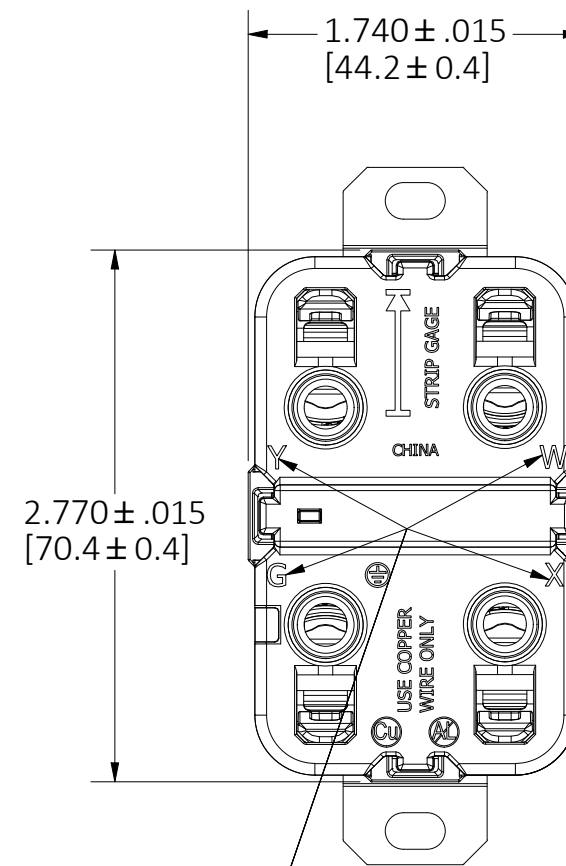
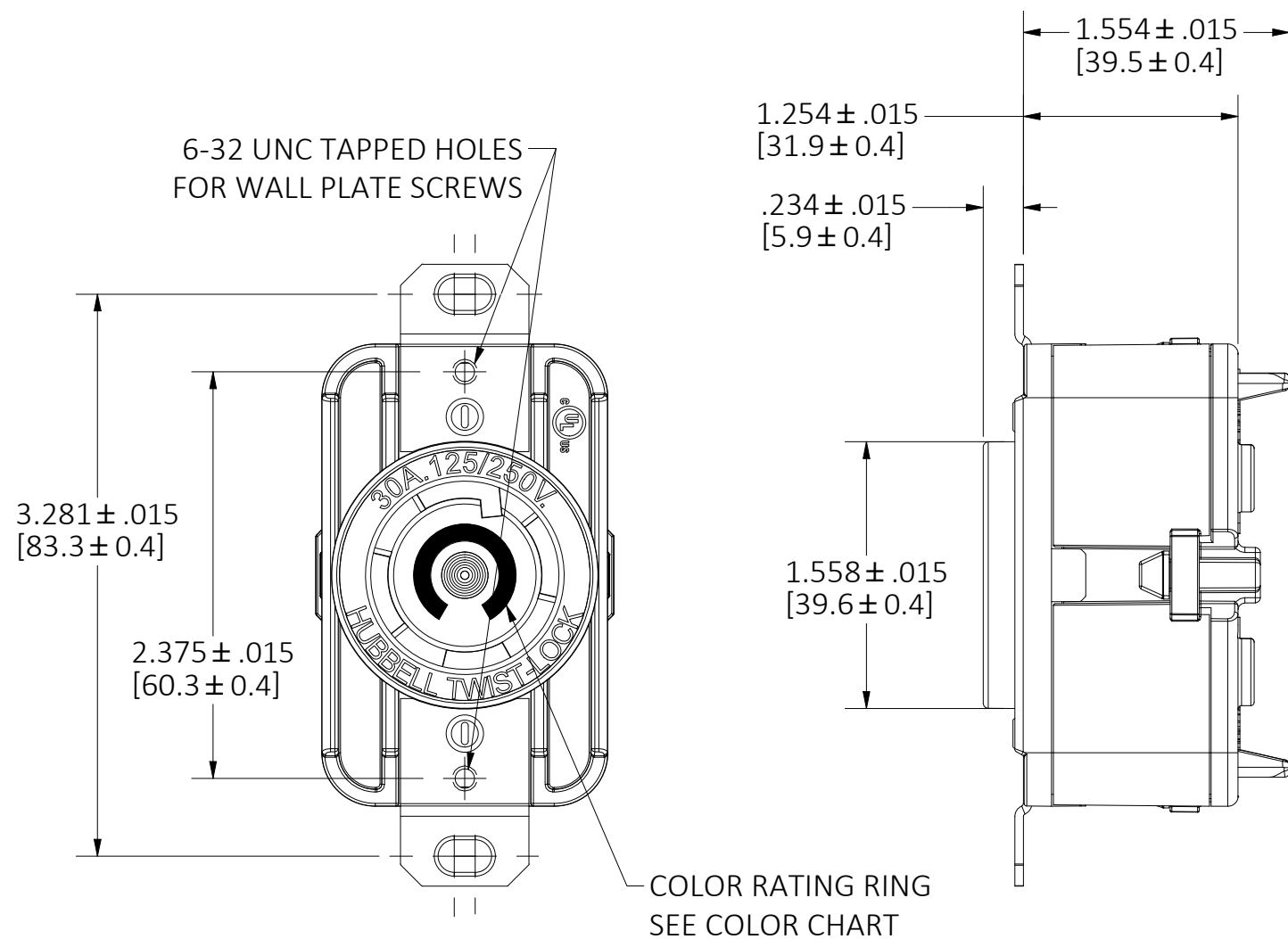

LIST OF PARTS		
DESCRIPTION	MATERIAL	FINISH
COVER	THERMOPLASTIC	
MID HOUSING	THERMOPLASTIC	
BASE	THERMOPLASTIC	
CONTACTS	BRASS	
SPRING	STEEL	
PLUNGER	THERMOPLASTIC	
GR. SHUNT	BRASS	
MOUNTING PLATE	BRASS	
RIVET	BRASS	

DIMENSION SHEET FOR CAT. NO.

CAT NO.	NEMA NO.	RATING	POLE/WIRE	CONFIGURATION	RATING RING COLOR
HBL2710ST	L14-30	30A 125/250V	3P/4W GROUNDING		ORANGE
HBL2720ST	L15-30	30A 250V 3Ø	3P/4W GROUNDING		BLUE
HBL2730ST	L16-30	30A 480V 3Ø	3P/4W GROUNDING		RED

NOTES:

- DIMENSIONS ARE IN INCHES [mm].
- WIRING TERMINAL ACCOMMODATION:
 - SOLID WIRE: 14 AWG - 10 AWG COPPER WIRE ONLY
 - STRANDED WIRE (INCLUDING COMPACT STRANDED): 14 AWG - 8 AWG COPPER WIRE ONLY
- CONDUCTOR STRIP LENGTH: 0.600" (15.24mm)

4	UPDATED RIVETS PER DCN 220908023832 RGP	DL	09/07/22
REV	DESCRIPTION	APP	DATE

THE DESIGN AND DIMENSIONS OF THE PRODUCT SHOWN ON THIS DRAWING ARE SUBJECT TO CHANGE WITHOUT NOTICE. DIMENSIONS ARE IN INCHES [mm].

TITLE
CUST. DWG, 30A 4 WIRE SPRING TERMINATION RECEPTACLE



WIRING DEVICE-KELLEMS
HUBBELL INCORPORATED
SHELTON, CT

TOLERANCES UNLESS OTHERWISE SPECIFIED .XX = ± .01 .XXX = ± .005 ANGLE TOL. ±2'	DR. BY RGP	SCALE 1 : 1
	CHK. BY TLS	DATE 05/17/19