

M-14127

2

LIST OF PARTS

DESCRIPTION	MATERIAL	FINISH
FLOOR BOX	PVC	GRAY
TOP MOUNTING ASSY	14 GA. STEEL	ZINC
GROUND PLATES	16 GA. STEEL	ZINC
WIRING CHANNEL	16 GA. STEEL	ZINC
REMOVABLE DIVIDERS	THERMOPLASTIC	
FASTENERS	STEEL	ZINC
FLUSH TEMP COVER	16 GA. STEEL	ZINC
RAISED TEMP COVER	THERMOPLASTIC	YELLOW
GROUND SCREWS	STEEL	GREEN

DIMENSION SHEET FOR CAT. NO. CFB4G30PFBE

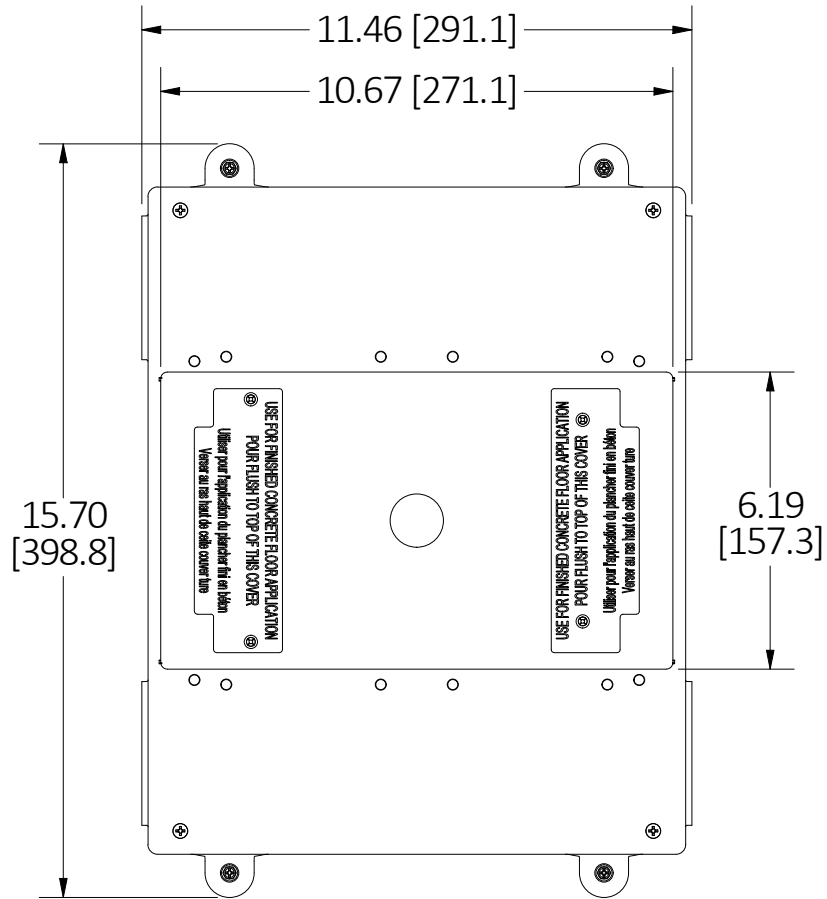

TOP VIEW

REMOVABLE DIVIDERS

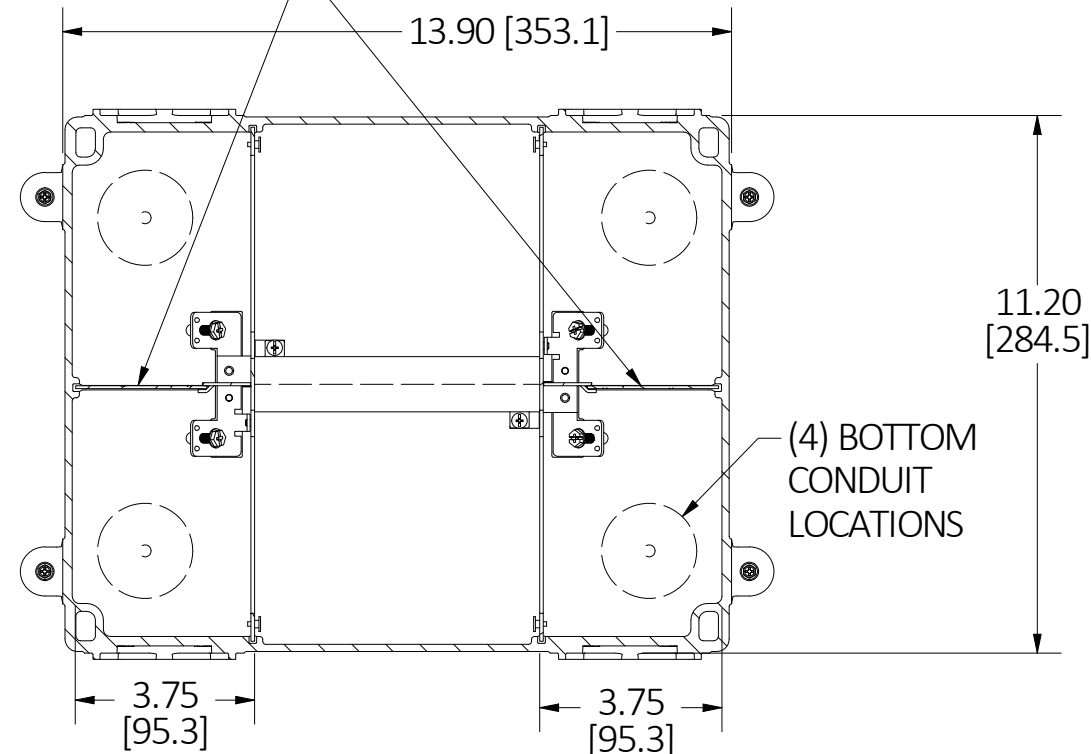

SECTION A-A
VIEW THROUGH BOX BELOW TOP

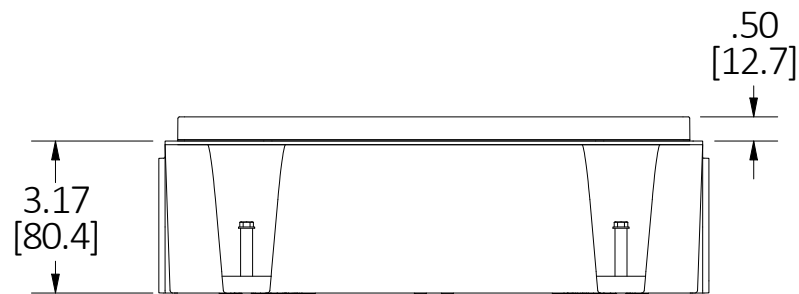

END VIEW

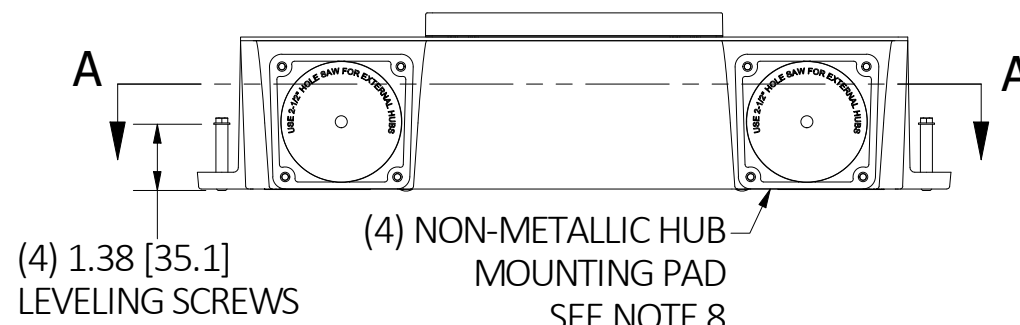

SIDE VIEW

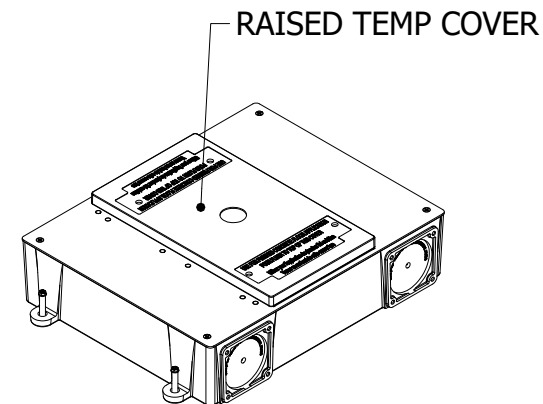

ISOMETRIC

NOTES:

1. ALL DIMENSIONS ARE IN INCHES AND [MILLIMETERS].
2. PRODUCT IS cULus LISTED. COMPLIES WITH UL 514A AND UL 514C.
3. MINIMUM CONCRETE POUR: 3.17" [80.4].
4. WIRING CHAMBER VOLUMES (RECESSED COVER): (4) 51 IN³ [835 CM³].
5. WIRING CHAMBER VOLUMES (FURNITURE FEED): (2) 118 IN³ [1934 CM³].
6. WIRING CHANNEL AREA: (2) .40 IN² [261 MM²].
7. MAXIMUM TERMINAL ADAPTER SIZES: 1-1/2 (BOTTOM), 1-1/4 (SIDES)
8. NON-METALLIC CONDUIT HUBS (CFBHUB125PVC, CFBHUB200PVC), SOLD SEPARATELY, MAY BE ATTACHED TO HUB MOUNTING PADS.

REV	DESCRIPTION	APP	DATE
2	REVISED PER EC 221108025468	KG	11/09/2022
1	ORIGINAL RELEASE PER 210929012903	SBW	2/2/22

THE DESIGN AND DIMENSIONS OF THE PRODUCT SHOWN ON THIS DRAWING ARE SUBJECT TO CHANGE WITHOUT NOTICE. DIMENSIONS ARE IN INCHES [mm].

TITLE CONCRETE FLOOR BOX, 4 GANG EXTENDED, FOR RECTANGULAR COVER, NON-METALLIC



WIRING DEVICE-KELLEMS
HUBBELL INCORPORATED
SHELTON, CT

TOLERANCES UNLESS OTHERWISE SPECIFIED
.XX = ± .01
.XXX = ± .005
ANGLE TOL. ±2°

DR. BY SBW
CHK. BY

SCALE 1/4
DATE 2/8/2021

B

M-14127

2