

M-14131 1

CONCENTRIC KNOCKOUTS

STYLE	TRADE SIZE
A	1/2", 3/4"
B	3/4", 1", 1-1/4" SEE NOTES 8 & 9
C	1/2", 3/4", 1", 1-1/4"
D	1/2", 3/4", 1", 1-1/4", 1-1/2"

LIST OF PARTS

DESCRIPTION	MATERIAL	FINISH
BOX ASSEMBLY	16 GA. STEEL	ZINC **
TOP MOUNTING ASSY	14 GA. STEEL	ZINC
GROUND WIRES	COPPER	
WIRING CHANNEL	16 GA. STEEL	ZINC
REMOVABLE DIVIDERS	16 GA. STEEL	ZINC
FASTENERS	STEEL	ZINC
FLUSH TEMP COVER	16 GA. STEEL	ZINC
RAISED TEMP COVER	THERMOPLASTIC	YELLOW

** CATALOG NO. CFB10G55CRE BOX ASSEMBLY IS GALVANIZED AND GREEN EPOXY COATED ON EXTERIOR SURFACE.

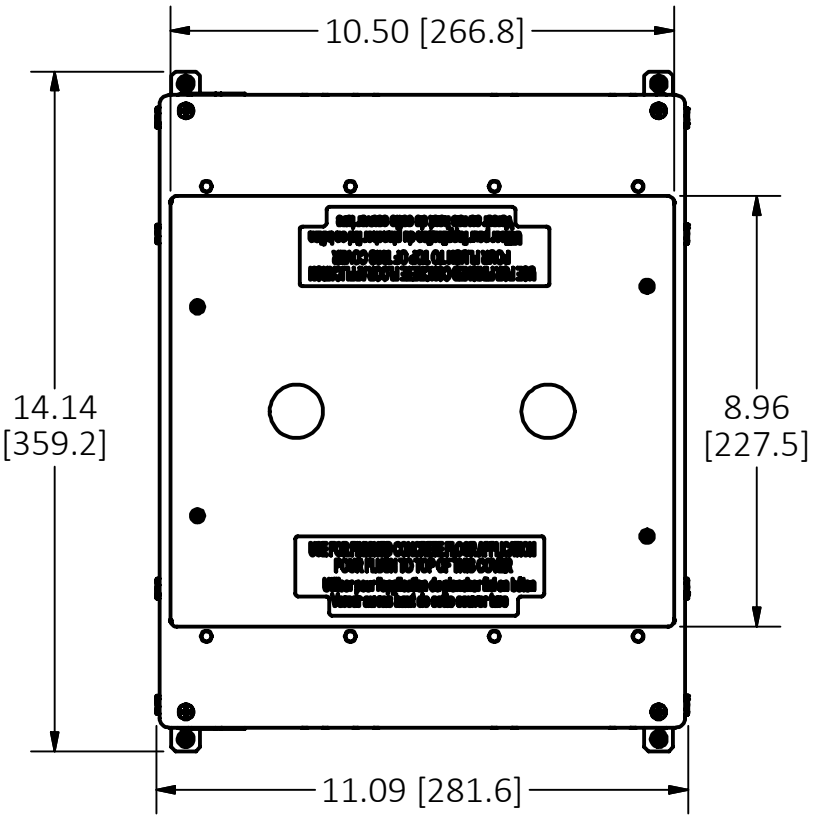

TOP VIEW

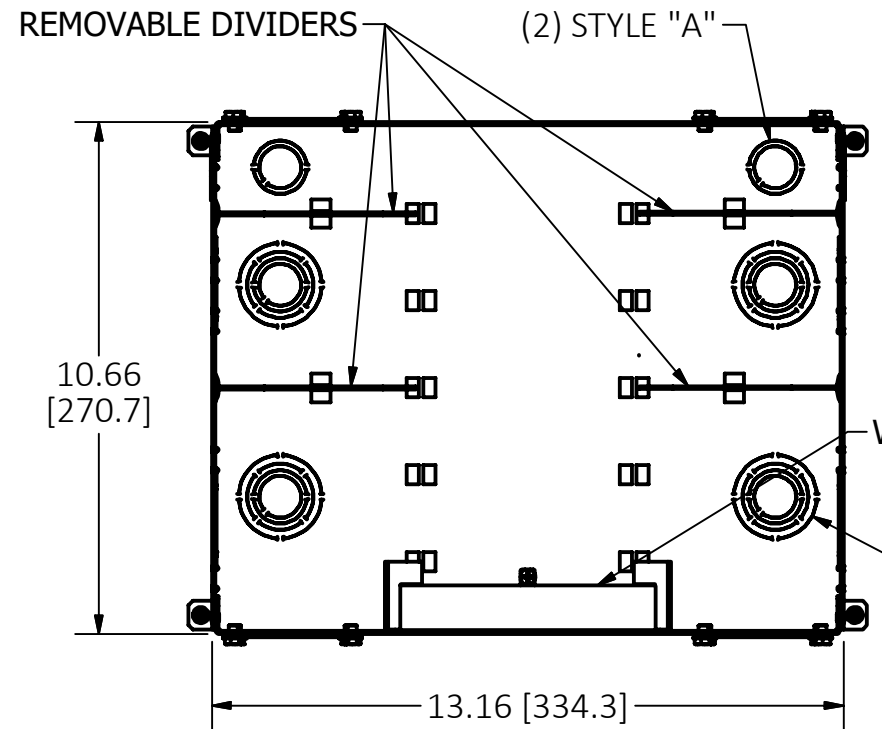

SECTION A-A
VIEW THROUGH BOX BELOW TOP

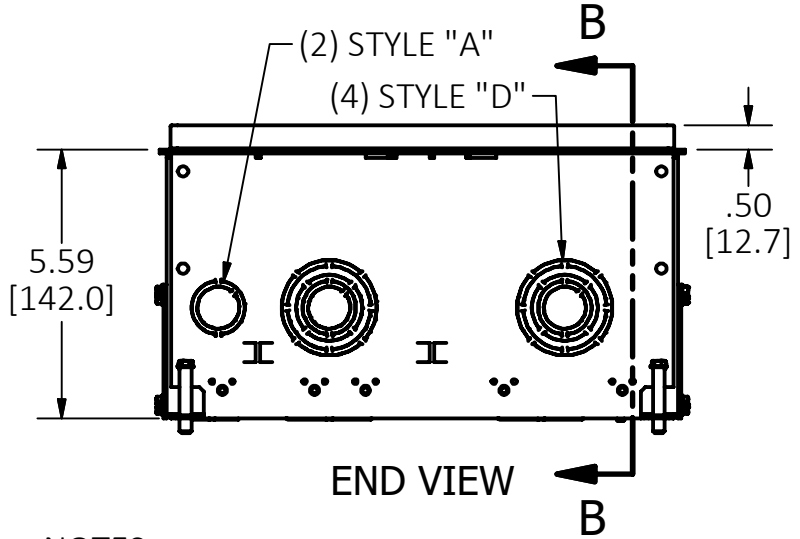

END VIEW

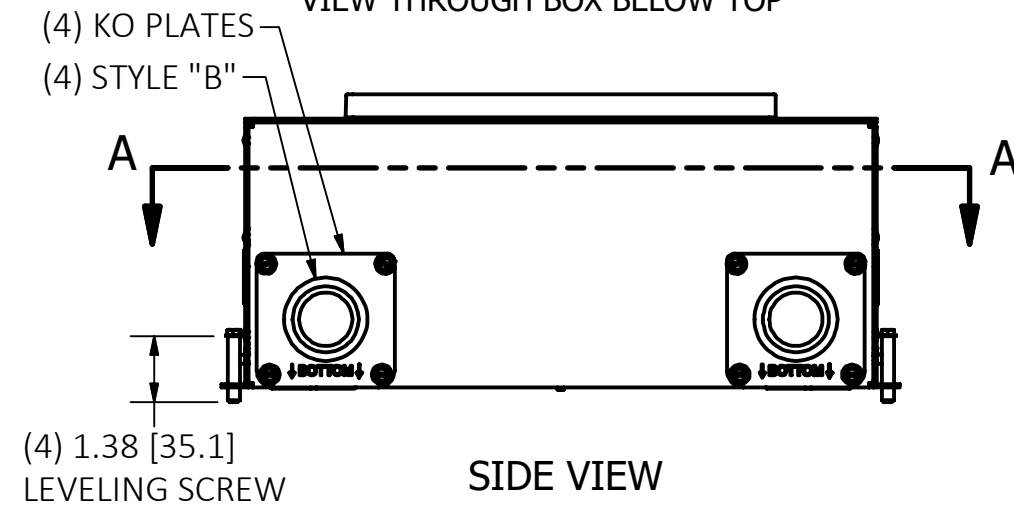

SIDE VIEW

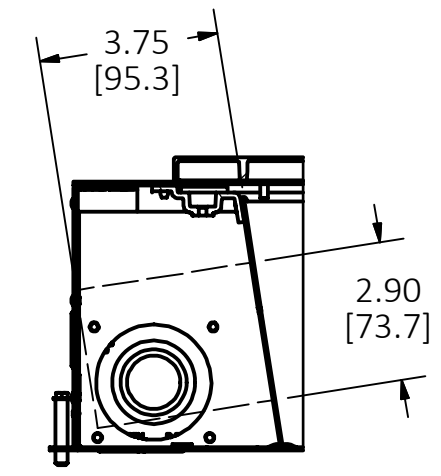

SECTION B-B
WIRING CHAMBERS

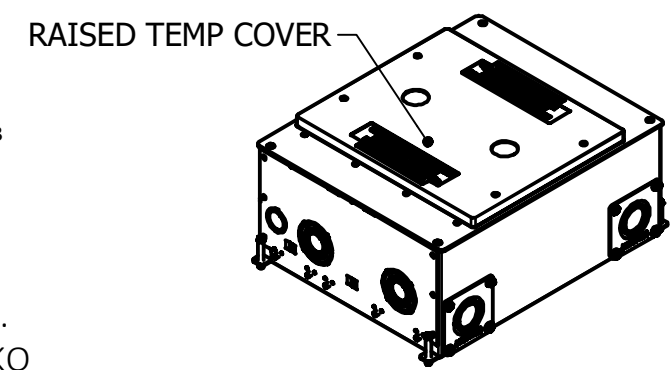

ISOMETRIC

- NOTES:
- ALL DIMENSIONS ARE IN INCHES AND [MILLIMETERS].
 - PRODUCT IS cULus LISTED. COMPLIES WITH UL 514A.
 - EACH GANG SUPPLIED WITH 6" [152.4] 12 GA. AWG GROUND PIGTAIL.
 - MINIMUM CONCRETE POUR: 5.59" [142].
 - WIRING CHAMBER VOLUMES (RECESSED COVER): (2) SMALL 35 IN³ [574 CM³], (2) MED 69.5 IN³ [1139 CM³], (2) LARGE 99 IN³ [1622 CM³]
 - WIRING CHAMBER VOLUMES (FURNITURE FEED): (2) 203.5 IN³ [3335 CM³]
 - WIRING CHANNEL AREA: 2.46 IN² [1589 MM²].
 - METALLIC CONDUIT HUBS (CFBHUB2) MAY BE USED IN PLACE OF KO PLATES, SOLD SEPARATELY.
 - NON-METALLIC CONDUIT HUBS (CFBHUB125PVC, CFBHUB200PVC) MAY BE USED IN PLACE OF KO PLATES, SOLD SEPARATELY.

CAGE CODE 74545

1	ORIGINAL RELEASE PER 210929012903	SBW	2/2/22
REV	DESCRIPTION	APP	DATE

THE DESIGN AND DIMENSIONS OF THE PRODUCT SHOWN ON THIS DRAWING ARE SUBJECT TO CHANGE WITHOUT NOTICE. DIMENSIONS ARE IN INCHES [mm].

TITLE CONCRETE FLOOR BOX, 10 GANG EXTENDED, FOR RECTANGULAR COVER



WIRING DEVICE-KELLEMS
HUBBELL INCORPORATED
SHELTON, CT

TOLERANCES UNLESS OTHERWISE SPECIFIED .XX = ±.01 .XXX = ±.005 ANGLE TOL. ±2'	DR. BY SBW	SCALE 1/4
	CHK. BY	DATE 2/8/2021

DIMENSION SHEET FOR CAT. NO. CFB10G55E, CFB10G55CRE B M-14131 1