

M-14194

1

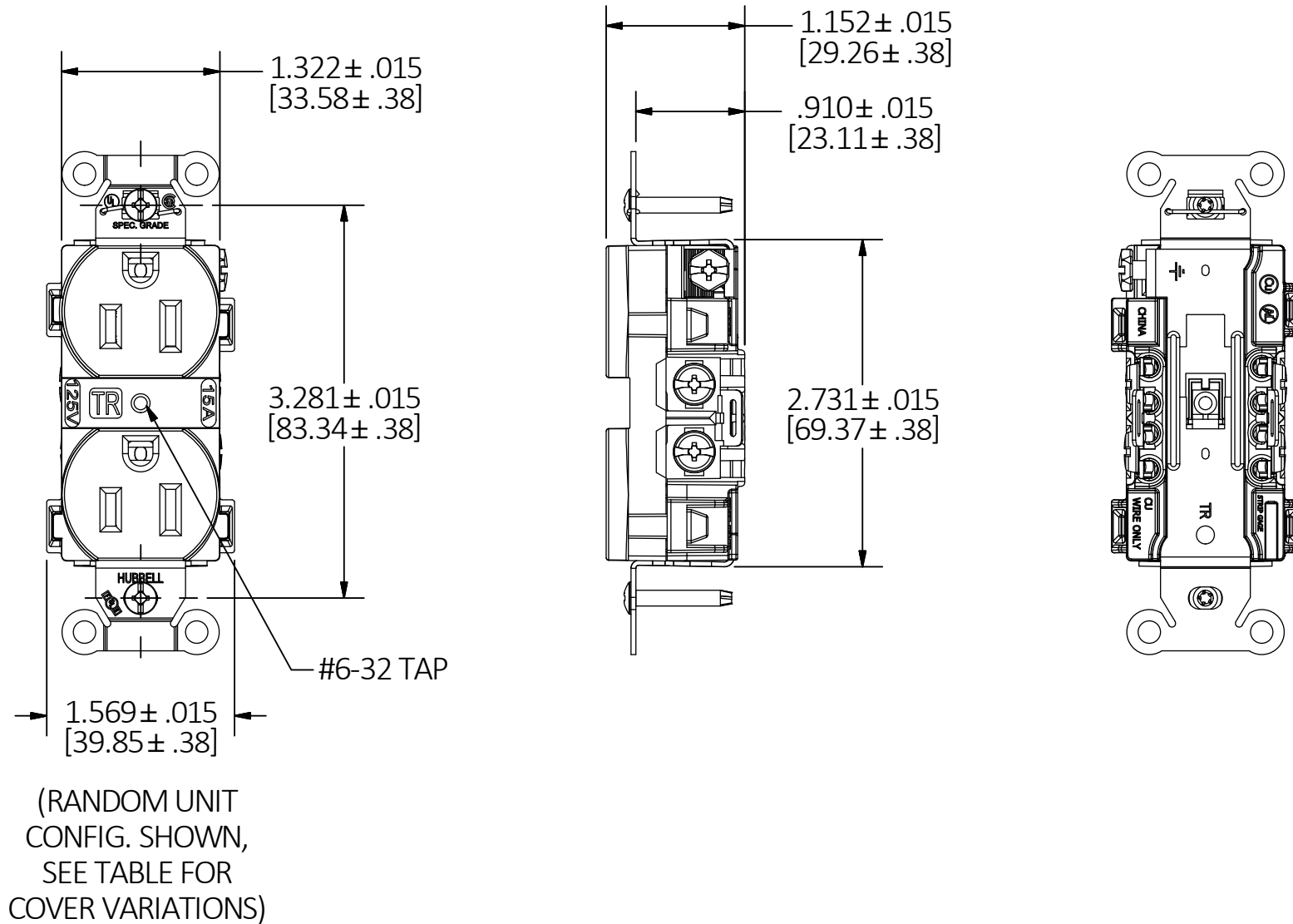

COVER VARIATIONS

15A TR
FLAT FACE

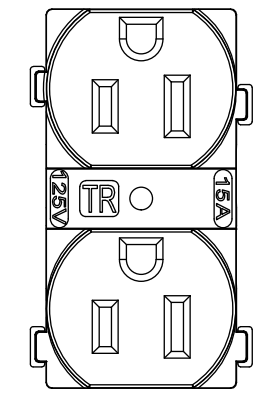

20A TR
FLAT FACE

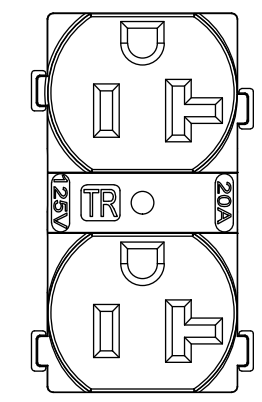

LIST OF PARTS

DESCRIPTION	MATERIAL	FINISH
TOP	PC	SPI A-3
BASE	PC	
LINE CONTACTS	BRASS	
GROUND CONTACTS	BRASS	
CONTACT SCREW (NEU)	STEEL	NI PLT
CONTACT SCREW (HOT)	STEEL	
BRIDGE	.04 GALV STL	
GROUND SCREW	STEEL	GREEN
STAPLE	S.S.	
WASHER	PVC FILM	BLACK
MOUNTING SCREW	STEEL	ZINC PLT

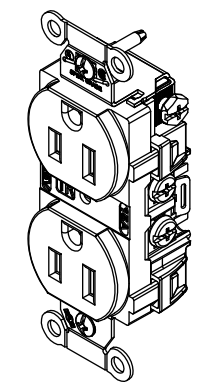

HUBBELL CATALOG NUMBERS

CONFIGURATION	BLACK	BROWN	GRAY	IVORY	LT. ALMOND	RED	WHITE
15A TR FLAT FACE	5252BLKTR	5252BTR	5252GTR	5252ITR	5252LATR	5252RTR	5252WTR
20A TR FLAT FACE	5352BLKTR	5352BTR	5352GTR	5352ITR	5352LATR	5352RTR	5352WTR

GENERAL NOTES:

1. DIMENSIONS ARE IN INCHES [MM].
2. ALL DEVICES UL LISTED, CSA & FED. SPEC. CERTIFIED
3. TERMINALS ACCOMMODATE #14 - #10 AWG COPPER WIRE ONLY.

CAGE CODE 74545

1	RELEASED FOR PRODUCTION PER DCN 190827075847 RGP	WHD	10/16/19
REV	DESCRIPTION	APP	DATE

THE DESIGN AND DIMENSIONS OF THE PRODUCT SHOWN ON THIS DRAWING ARE SUBJECT TO CHANGE WITHOUT NOTICE. DIMENSIONS ARE IN INCHES [mm].

TITLE
 DUPLEX RECEPTACLE, 15A & 20A,
 TAMPER RESISTANT, BACK & SIDE WIRE

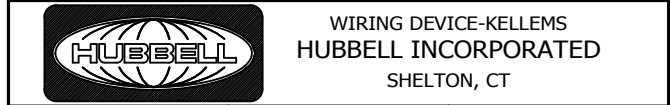

TOLERANCES UNLESS OTHERWISE SPECIFIED .XX = ± .01 .XXX = ± .005 ANGLE TOL. ±2'	DR. BY RGP	SCALE 3 : 4
	CHK. BY WHD	DATE 10/16/19

DIMENSION SHEET FOR CAT. NO. SEE TABLE

B

M-14194

1